

VUE **30**
40

SXY

Manual



SandenVendo America, Inc.
10710 Sanden Drive • Dallas, Texas 75239



SXY

TABLE OF CONTENTS



Table of Contents

Safety	S-1 - S-17
Commitment to Safety.....	S-2
Vendor Installation.....	S-3
Electrical Hazards	S-7
Mechanical Hazards.....	S-10
Refrigeration Hazards	S-11
Temperature Hazards.....	S-11
Substitutions and Modifications.....	S-12
Consumer Safety Warning	S-14
Parts, Sales, and Service Centers	S-15
Parts, Sales, and Service Centers for Latin America	S-16
General Information	G-1 - G-8
General Information	G-2
Initial Set-up	G-3
Tray Label Installation	G-5
Loading Instructions	G-6
Vend Mechanism Part Description	G-6
Cleaning Information	CL-1 - CL-4
Care and Cleaning	CL-2
Programming	P-1 - P-30
Vec 15 Programming Operation.....	P-2
Diagnostics.....	P-3
Coin Payout.....	P-3
Tube Fill	P-4
Test Mode.....	P-4
Calibration	P-9
Cash Data	P-11
Sales Data.....	P-11
Set Price.....	P-11
Space to Sales	P-12
Discount Counter	P-14
Free Counter	P-14
Configuration.....	P-15
Door Closed Password	P-17
Set Language.....	P-17
Set Clock.....	P-18
Lighting.....	P-18
Refrigeration.....	P-20
Sales Block	P-22
Discount	P-24
Override	P-26



Custom Message	P-26
Return	P-27
Wiring Diagram	P-28
Custom Space to Sales Diagram.....	P-30
Cabinet Parts	C-1 - C-11
Cabinet Assembly	C-2
Refrigeration Assembly	C-4
Power Distribution Assembly.....	C-5
Harness Quick Guide.....	C-7
Shelves & Trays Parts	ST-1 - ST-5
Shelves & Trays Assembly.....	ST-2
Tray Assembly.....	ST-3
Door Parts	D-1 - D-29
Reading a Parts List.....	D-2
Hardware List.....	D-4
Door Assembly	D-6
Hand Assembly	D-10
Z Housing Assembly	D-12
Y Rail Assembly - Left/Hinge Side	D-13
Y Rail Assembly - Right/Latch Side.....	D-15
X Rail Assembly	D-18
X Axis Carriage Assembly.....	D-19
Coin Entry & Coin Return Assembly	D-21
Delivery Hopper & Flap Assembly.....	D-23
Delivery Hopper Assembly.....	D-26
T-Handle Lock Assembly.....	D-27
Harness Quick Reference Guide	D-28
Wiring Diagram	D-29
Maintenance	M-1 - M-9
Preventative Maintenance Suggestions.....	M-2
Lubrication Guide	M-2
Refrigeration Operation.....	M-3
Refrigeration Parts Description	M-6
Troubleshooting	T-1 - T-14
Parts Return Procedure	T-2
Error Codes.....	T-3
General Machine Troubleshooting	T-10



SXY

SAFETY SECTION



A COMMITMENT TO SAFETY

SandenVendo America is committed to safety in every aspect of our product design. SandenVendo America is committed to alerting every user to the possible dangers involved in improper handling or maintenance of our equipment. The servicing of any electrical or mechanical device involves **potential hazards**, both to those servicing the equipment and to users of the equipment. These hazards can arise because of improper maintenance techniques. The purpose of this manual is to alert everyone servicing SandenVendo America equipment of potentially hazardous areas, and to provide **basic safety guidelines** for proper maintenance.

This manual contains various **warnings** that should be carefully read to minimize the risk of personal injury to service personnel. This manual also contains service information to insure that proper methods are followed to avoid damaging the vendor or making it unsafe. It is also important to understand these **warnings** are not exhaustive. SandenVendo America could not possibly know, evaluate, or advise of all of the conceivable ways in which service might be done. Nor can SandenVendo America predict all of the possible hazardous results. The safety precautions outlined in this manual provide the basis for an effective safety program. Use these precautions, along with the service manual, when installing or servicing the vendor.

We strongly recommend a similar commitment to safety by every servicing organization. **Only properly-trained personnel should have access to the interior of the machine.** This will minimize the potential hazards that are inherent in electrical and mechanical devices. SandenVendo America has no control over the machine once it leaves the premises. It is the owner or lessor's responsibility to maintain the vendor in a safe condition. See Section I of this manual for proper installation procedures and refer to the appropriate service manual for recommended maintenance procedures. If you have any questions, please contact the Technical Services Department of the SandenVendo America office nearest you.

SAFETY RULES

- **Place and store unit inside. Outdoor use or storage voids warranty.**
- Read the Safety Manual before installation or service.
- Test for proper grounding before installing to reduce the risk of electrical shock and fire.
- Disconnect power cord from wall outlet or air dam before servicing or clearing product jams. The vending mechanism can trap and pinch hands.
- Use only fully-trained service technicians for Power-On servicing.
- Remove any product prior to moving a vendor.
- Use adequate equipment when moving a vendor.
- Always wear eye protection, and protect your hands, face, and body when working near the refrigeration system.
- Use only authorized replacement parts.
- Be aware of inherent dangers in rocking or tipping a vending machine.



SECTION I: VENDOR INSTALLATION

- A. Vendors are large, bulky machines of significant size and weight. Improper handling can result in injury. When moving a vendor, carefully plan the route to be taken and the people and equipment required to accomplish the task safely.
- B. Remove all tape, shipping sealant, and Styrofoam from the vendor. Loosen any shipping devices used to secure interior parts during shipping. Remove the wooden shipping base attached to the vendor base by the vendor leveling screws. Make certain the leveling screws are in place and functional.
- C. Position the vendor three to four inches (7.6 cm to 10.2 cm) from a well-constructed wall (of a building or otherwise) on a flat, smooth surface.

IMPORTANT: *The vendor requires three inches (7.6 cm) of air space from the wall to ensure proper air circulation to cool the refrigeration unit.*

- D. Adjust the leveling screws to compensate for any irregularities on the floor surface. Ideally, no adjustment will be necessary and the leveling legs will be flush with the bottom of the vendor. A spirit level is a useful aid to level the vendor. When the outer door is open, it will remain stationary if the vendor is properly leveled. Vendors must be level to ensure proper operation and to maintain stability characteristics. Do not add legs to the vendor. **The leveling legs shall not raise the vendor more than 1 1/8 inch above the ground.**
- E. Check the manufacturer's nameplate on the left or right side of the vendor's cabinet to verify the main power supply requirements of the vendor. Be sure the main power supply matches the requirements of the vendor. To ensure safe operation, plug the vendor only into a properly grounded outlet.
DO NOT USE EXTENSION CORDS.
- F. Recommended voltage specs = 115V \pm 10%
- G. Dedicated 15A service required for 1 machine.

NOTE: Any power supply variance more than \pm 10% may cause the vendor to malfunction.

- * Power outlets must be properly **grounded**.
- * Power outlets must be properly **polarized**, where applicable.

Test the outlets using the following information.
(Refer to Figure 1 on Page S-4.)

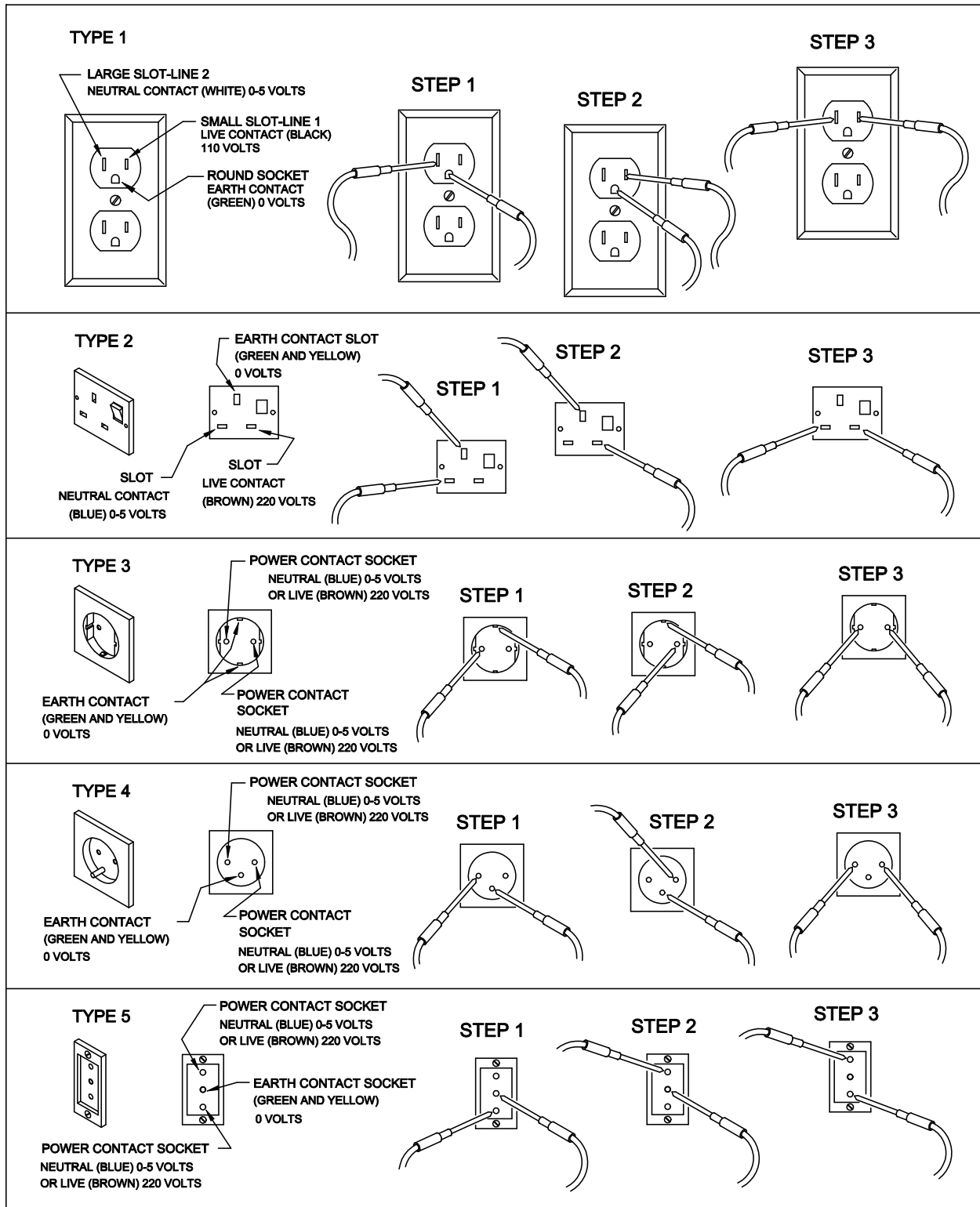

FIGURE 1



SECTION I: VENDOR INSTALLATION (CONTINUED)

For Type 1 and Type 2 outlets, test for Grounding and Polarization as follows:

1. With a test device (volt meter or test light), connect one probe to the receptacle's neutral contact and the other to the live contact. The test device should show a reaction.
2. Connect one probe to the receptacle's earth contact and the other to the live contact. The test device should show a reaction.

For Type 3 through Type 5 outlets, test for Grounding as follows:

1. With a test device (volt meter or test light), determine which of the receptacle's power contacts is the live contact.
 - A. Connect one probe to the receptacle's earth contact.
 - B. Connect the second probe to the left (or upper) power contact. If a reaction occurs, this is the live power contact. If a reaction does not occur, move the second probe to the right (or lower) contact. A reaction should occur, indicating that this is the live power contact.
2. Connect one probe to the receptacle's live power contact (as determined in step 1). Connect the second probe to the other power contact (neutral). The test device should show a reaction.

IF THE ABOVE CONDITIONS ARE NOT MET FOR THE GIVEN OUTLET TYPE, CONTACT A LICENSED ELECTRICIAN AND HAVE THE NECESSARY CORRECTIONS MADE.

H. Door Support (Figure 2)

The door support is to ensure that the outer door closes squarely to the cabinet.

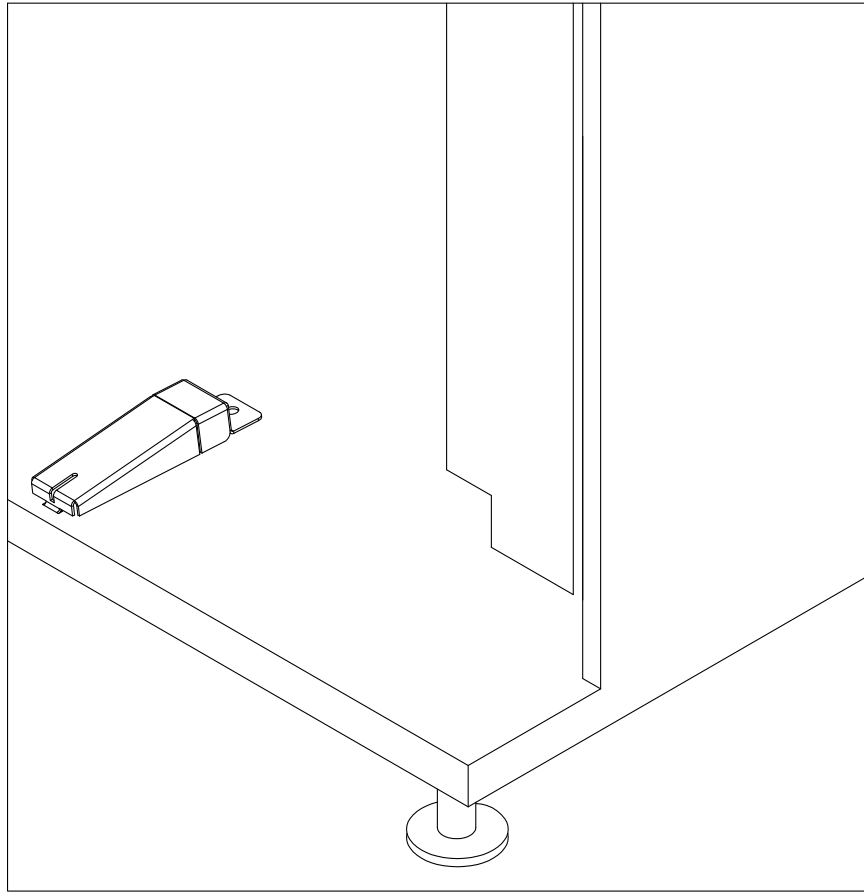

FIGURE 2

NOTE: Refer to the appropriate parts and service manual for detailed instructions, operating principles, and recommended maintenance intervals and procedures.



SECTION II: ELECTRICAL HAZARDS

GENERAL

SandenVendo America, Inc. vending machines are provided with the appropriate power supply setting for your area. Some models are equipped with step-down transformers, as required. This enables the vending machine to operate on different main voltages. Refer to Section I. E. for information to determine the main power requirements. Refer to the appropriate service manual for details of step-down transformer operations.

The power sources just mentioned are standard for both household and commercial lighting and appliances. However, careless or improper handling of electrical circuits can result in injury or death. Anyone installing, repairing, loading, opening, or otherwise servicing a vending machine should be alerted to this point. Apply all of the normal precautions observed in handling electrical circuits, such as:

- Refrigeration servicing to be performed by qualified personnel only.
- Unplug the vendor or move power switch to off position before servicing or clearing product jams.
- Replace electrical cords if there is any evidence of fraying or other damage.
- Keep all protective covers and ground wires in place.
- Plug equipment into outlets that are properly grounded and polarized (where applicable), and protected with fuses or circuit breakers.
- All electrical connections must be dry and free of moisture before applying power.

A. Grounding Systems

SandenVendo America, Inc. vending machines are provided with the appropriate service cord for the power supply in your area. The service cord will connect to the matching electrical outlet. Always ensure that the outlet to be used is properly grounded before plugging in the vendor. (See pages S-3 through S-5.)



The electrical grounding system also includes the bonding of all metal components within the vendor. This involves a system of bonding wires identified by green or green and yellow marking. The system uses serrated head screws, lock washers, and star washers to ensure the electrical connection between parts. Maintenance of vending equipment may involve disassembly. Include the above items when reassembling, even if the vending machine may appear to function normally without them. Omitting any of these items can compromise a link in the grounding system. See the appropriate service manual or kit instructions for components and assembly instructions.

SECTION II: ELECTRICAL HAZARDS (CONTINUED)

B. Servicing with “Power Off”

For maximum safety, unplug the service cord from the wall outlet before opening the vendor door. This will remove power from the equipment and avoid electrical and mechanical hazards. Service personnel should remain aware of possible hazards from hot components even though electrical power is off. See the appropriate sections of this manual for further information.

C. Servicing with “Power On”

Some service situations may require access with the power on. Power on servicing should be performed **only by fully-qualified service technicians**. Particular caution is required in servicing assemblies that combine electrical power and mechanical movement. Sudden movement (to escape mechanical action) can result in contact with live circuits and vice versa. It is therefore doubly important to maintain maximum clearances from both moving parts and live circuits when servicing.

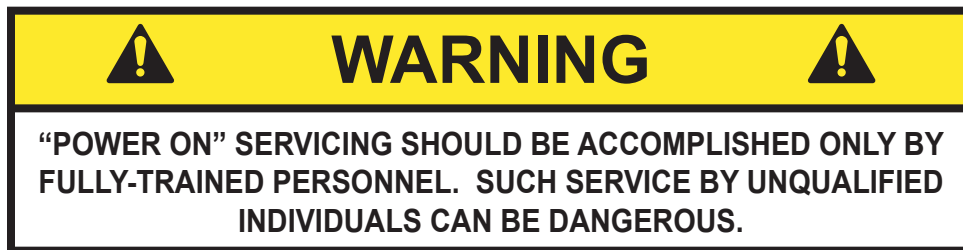

Power to lighting and refrigeration system is shut off automatically by the electronic controller when the outer door is opened. However, it is strongly recommended that servicing the lighting system or the refrigeration system only be performed after unplugging the vendor power cord, either at the wall outlet, or at the service cord power outlet, located at the front of the power distribution panel. (See Figure 3 on facing page.)

NOTE: For power-on servicing of the vendor’s lighting system, turn lighting power on by accessing the Lights test function of the electronic controller.

The VUE vendor features a circuit interrupting style ballast. If the lamp is replaced, you must cycle the power to the machine to bring the light back on.

For power-on servicing of the vendor’s refrigeration system, turn refrigeration power on by accessing the Compressor test function of the electronic controller.

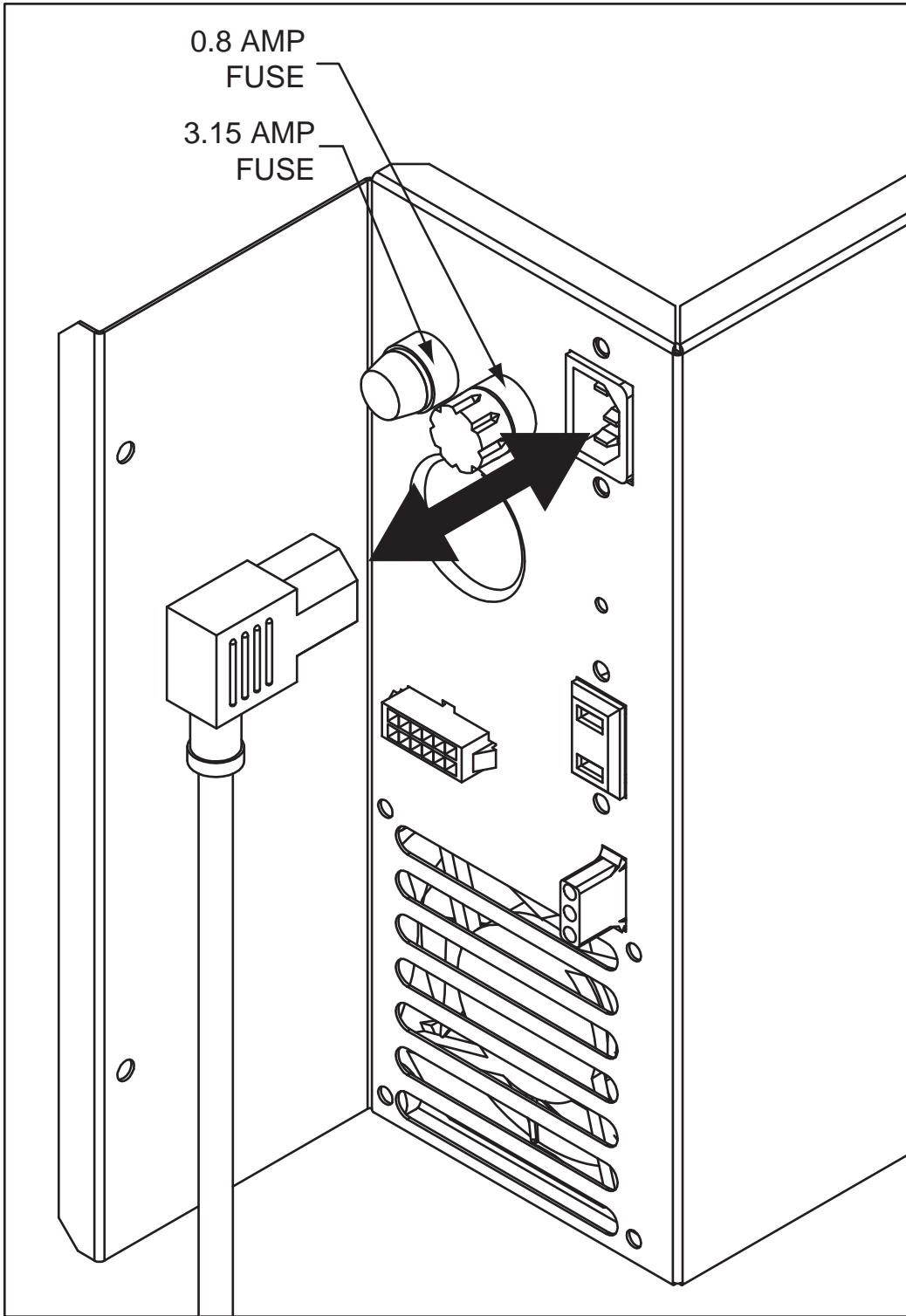

FIGURE 3

SECTION III: MECHANICAL HAZARDS

A. Servicing of Moving Parts and Assemblies

When servicing assemblies involving moving parts, **use extreme caution!!** Keep fingers, hands, loose clothing, hair, tools, or any foreign material clear of entrapment.

As noted before under the electrical hazards section, Power On servicing should **only** be performed by qualified personnel. Refer to and heed the warnings noted in the electrical hazards section. These warnings refer to the potential hazards associated with electrical power and moving parts. Always maintain maximum clearances from electrical and moving parts.

Always install protective covers and guards when reassembling equipment.





SECTION IV: REFRIGERATION HAZARDS

GENERAL

Refrigeration systems involve both electrical power and mechanical action. These systems may present any of the potential dangers shown in the sections on electrical and mechanical hazards contained in this manual. See Sections II and III for further information.

A. **Compressed Refrigerant**

Refrigeration systems involve the compression and evaporation of gases. The pressures contained represent a potential hazard if suddenly released in confined areas. Caution is required when performing maintenance tests or repairs. All testing of sealed refrigeration systems must be done by trained personnel who are familiar with the systems and pressures involved.

B. **Physical Protection**

The accidental release of refrigerant gases can result in physical injuries. Always wear protective glasses and protect your hands, face, and body when working near the refrigeration system.



SECTION V: TEMPERATURE HAZARDS

GENERAL

Maintenance personnel should be alerted to the potential hazards from hot metal surfaces. High temperatures may be present throughout the refrigeration system even though electrical power has been removed.



SECTION VI: SUBSTITUTIONS AND MODIFICATIONS

GENERAL

Unauthorized changes or the substitution of unauthorized parts can compromise the equipment designs. This can result in unsafe conditions for either the service personnel or the equipment users. Always refer to the appropriate parts and service manual for replacement parts and maintenance instructions. If questions arise, contact the Technical Services Department of the SandenVendo America, Inc. office in your area.

When servicing the vending machine, always reassemble all components to their original location and position. Maintain the correct routing for tubing, electrical wiring, etc.. Replace all clamps, brackets, and guides to their original locations. Replace all tubing, sleeving, insulating material, and protective covers to their original condition.

	WARNING	
<p>VENDO EQUIPMENT HAS BEEN PROVIDED WITH APPROPRIATE PROTECTIVE DEVICES TO PROTECT AGAINST THE POSSIBILITY OF OVERHEATING AND FIRE AS A RESULT OF EQUIPMENT OR COMPONENT FAILURES. SUBSTITUTION, MODIFICATION, OR BYPASSING OF SUCH PROTECTIVE DEVICES CAN CREATE DANGEROUS CONDITIONS. PROTECTIVE CIRCUITS SHOULD NEVER BE BYPASSED, AND FAILED PROTECTIVE DEVICES MUST BE REPLACED ONLY WITH FACTORY-AUTHORIZED PARTS.</p>		

A. **Service Cord Replacement**

SandenVendo America, Inc. vending machines are furnished with unique power supply cords. If replacement becomes necessary, consult the appropriate parts and service manual and order the correct replacement cord for the model of vending machine in question. Do not use substitute replacement cords. Only authorized service personnel with appropriate training should replace the vending machine service cord. If a question should arise concerning which service cord to order, contact the Technical Services Department of the SandenVendo America, Inc. office in your area.



SECTION VI: SUBSTITUTIONS AND MODIFICATIONS (CONTINUED)

	WARNING	
THIS APPLIANCE MUST BE EARTHED. IMPORTANT!		

The wires in the main leads are colored in accordance with the following code:

110v/120v	220v/240v	
Green	Green and Yellow.....	Earth
White	Blue.....	Neutral
Black	Brown.....	Live

SECTION VII: CONSUMER SAFETY WARNING



GENERAL

There have been incidents, including fatalities, when vending machines have been vandalized by being pulled over in an attempt to obtain free product or money.

To warn of the danger involved in tipping, shaking, or rocking the vending machine, a decal has been designed to be affixed to vending machines. SandenVendo America will supply sufficient decals to be placed on all machines, on request. If you have any questions, contact the Technical Services Department of the SandenVendo America office in your area.

THE FOLLOWING DECAL SHOULD BE PLACED IN A POSITION ON THE VENDOR CONTROL PANEL AT EYE LEVEL



ENGLISH



FRENCH

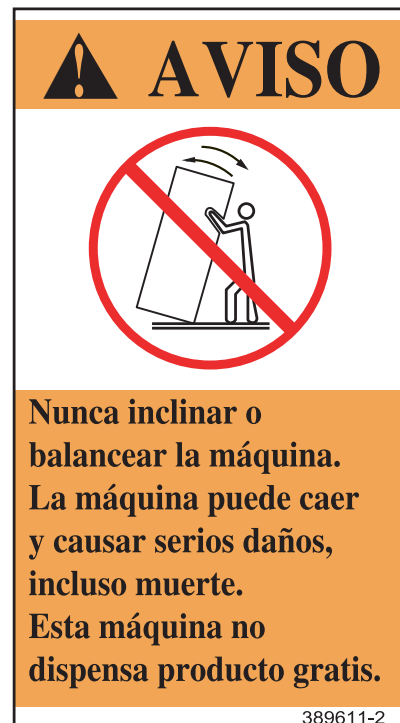

SPANISH



**SECTION VIII: PARTS, SALES, & SERVICE CENTERS
OF THE SANDEN COMPANY**

AREA	ADDRESS	PHONE NUMBERS
United States, Canada	SandenVendo America, Inc. 10710 Sanden Drive Dallas, TX 75238-1335 U.S.A.	Tel: (800) 344-7216 ext. 3368 Fax: (800) 541-5684
Japan	Sanden International Corporation 31-7 Taito 1-Chome Taito-ku Tokyo 110, Japan	Tel: (81) 3-3835-1321 Fax: (81) 3-3833-7096
Europe, Mid-East Africa, Mid-Asia	Vendo GMBH Spangerstr. 22, P.O. Box 130940 40599 Dusseldorf Germany	Tel: (49) 211-74-039-0 Fax: (49) 211-7488541
Australia, New Zealand	Sanden International Pty. Ltd. 54 Allingham St., Condell Park N.S.W. 2200 Australia	Tel: 61-2-9791-0999 Fax: 61-2-9791-9029
Singapore, Hong Kong, Indonesia, Phillippines, India	Sanden International (Singapore) Pte., Ltd. Sanden House, 25, Ang Mo Kio St. 65 Singapore 569062 The Republic of Singapore	Tel: 65-482-5500 Fax: 65-482-1697
Taiwan	Sanden International Taiwan Corp. No, 21-6, Sec 1 Tun Hwa S. Rd., Taipei, Taiwan Taiwan, ROC	Tel: 886-2-570-6106 Fax: 886-2-577-1959
Belgium	N.V. Vendo Benelux, S.A. Industrial Research Park N.O.H. 13 Font St. Landry 1120 Brussels Belgium	Tel: 32-2-268-2595 Fax: 32-2-268-2862
England	Vendo UK Ltd. Vendo House Kingsclere Road Basingstoke, Hants RG21, 5GU Great Britain	Tel: 44-1256-479309 Fax: 44-1256-844469
Italy	Vendo Italy S.p.A. Casella Postale 9 1-15033 Casale Monferrato Italy	Tel: 39-142-335111 Fax: 39-142-5623-48
Spain	Vendo Iberia, S.A. C/ Sant Ferran No. 92 Poligono Industrial la Almeda, Sector P-1 08940 Cornellà, (Barcelona), Spain	Tel: 343-474-1555 Fax: 343-474-1842



**PARTS, SALES, & SERVICE CENTERS OF THE SANDEN COMPANY
FOR LATIN AMERICA**

AREA	ADDRESS	PHONE NUMBERS
Mexico	Vendo de Mexico Carreta Mexico - Tequisquiapan Km 3.2 San Juan del Rio, Queretaro C.P. 76800	Tel: (52) 427 2718096 Fax: (52) 427 2718077
Mexico	IMI Cornelius de Mexico, S.A. de C.V. Manual Dublan No. 35 Col. Tacubaya, Deleg. Miguel Hidalgo C.P. 11870 Mexico	Tel: (52 55) 5272-7904 Fax: (52 55) 5273-5949
Central America	SandenVendo America, Inc. 10710 Sanden Drive Dallas, TX 75238-1335 U.S.A.	Tel: (214) 765-9066 Fax: (214) 221-7010
South America	SandenVendo America, Inc. 10710 Sanden Drive Dallas, TX 75238-1335 U.S.A.	Tel: (214) 765-9066 Fax: (214) 221-7010



NOTES



SXY

GENERAL INFORMATION SECTION



This manual contains programming, operation, and complete parts and electrical wiring diagrams.

The controller is a microprocessor which will permit pricing per selection from 0.00 to 99.99. This machine also has space-to-sales programming as well as energy savings modes.

SXY Model Numbers	VUE30XY	VUE40XY
Dimensions H x W x D	72" x 34" x 38.5"	72" x 41.5" x 39"
Shipping Weight	750 lbs	800 lbs
Shelves	5 - 7	5 - 7
Trays per shelf	3	4
Facings / shelf	6	8
Total # of facings:		
5 shelf	30	40
7 shelf	42	56
Total capacity:		
20 oz bottle	240	320
12 oz can	378	504

Dimensions and shipping weight will vary slightly due to manufacturing tolerances, shipping boards and whether or not coinage is installed.



WARNING

Load this unit with shelf-stable product ONLY.

This unit is not equipped to safely vend perishable product.

Loading this unit with improper product may result in serious illness or injury to the consumer.

1125135



INITIAL SET-UP

A. UNPACKING

Remove all plastic film, cardboard and tape from the outside of the vendor. Loosen any shipping devices used to secure interior parts during shipment (backspacer, shims or spacers).

To remove shipping boards from base, raise vendor on a well-stabilized lifting device. Remove the leveling bolts which hold the boards in place and remove the boards. Replace bolts to equal heights in the threaded holes. Another method to remove shipping boards is to split the boards apart. Using a pinch bar or a heavy screwdriver and hammer, insert tool into the slots and force the boards apart. **The leveling legs shall not raise the vendor more than 1 1/8 inch above the ground.**

B. POSITIONING

IMPORTANT: PLACE THE VENDOR IN DESIRED LOCATION AT LEAST THREE INCHES (7.6CM) AWAY FROM ANY REAR OBSTRUCTION. This is for proper air flow through the refrigeration compartment. The refrigeration system requires rear to front air circulation for proper operation.

C. POWER SUPPLY CONNECTION

CAUTION: DO NOT USE AN EXTENSION CORD!

The vendor's power requirements will vary depending upon the country it was purchased for. To verify the power requirements of the vendor, check the serial plate located on the hinged side of the outer door. The power requirements are listed on the serial plate.

To insure safe operation of the vendor, the vendor's power supply must be a properly grounded and polarized outlet. Before plugging the vendor into the outlet, test the outlet to confirm it will meet the vendor's power requirements. If the power supply of the outlet is different from the power requirements of the vendor, a transformer may be necessary.

If the power requirements are not properly met, contact a licensed electrician and have the necessary correction made.

Should you require additional information, contact the Technical Services Department of the SandenVendo America, Inc. office in your area.

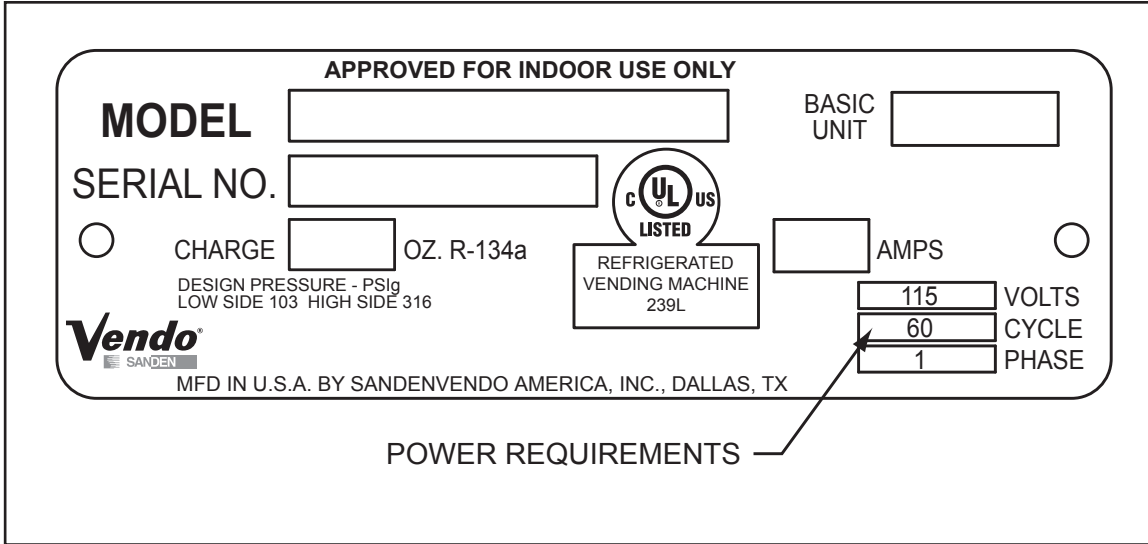

FIGURE 1

NOTE: The **Model** number of the vending machine is located on the top, left hand corner of the serial plate. A typical model number could read “320GFT001”. The 320 is the model number, GFT represents the product line of the vendor, and the remaining digits tell what options are included.

TRAY LABEL INSTALLATION

Insert column labels as shown in Figure 2. The column number is a two digit number where the first digit is a shelf number and the second number is called out a column on that shelf. Shelves are numbered starting with “1” from the top shelf. Columns are numbered starting from “0” on the left most column. So the leftmost column on the top shelf is “10” and toward the right, the column number is increased by the increment of 1 which is called out “11”, “12”, and so on. The next shelf down leftmost column is numbered “20” and the shelf under that starts with number “30” and so on.

NOTE: A shelf that does not have trays on it should not be numbered.

Selection button number labels can be inserted in each product pusher as indicated.

BASIC LOAD SET-UP

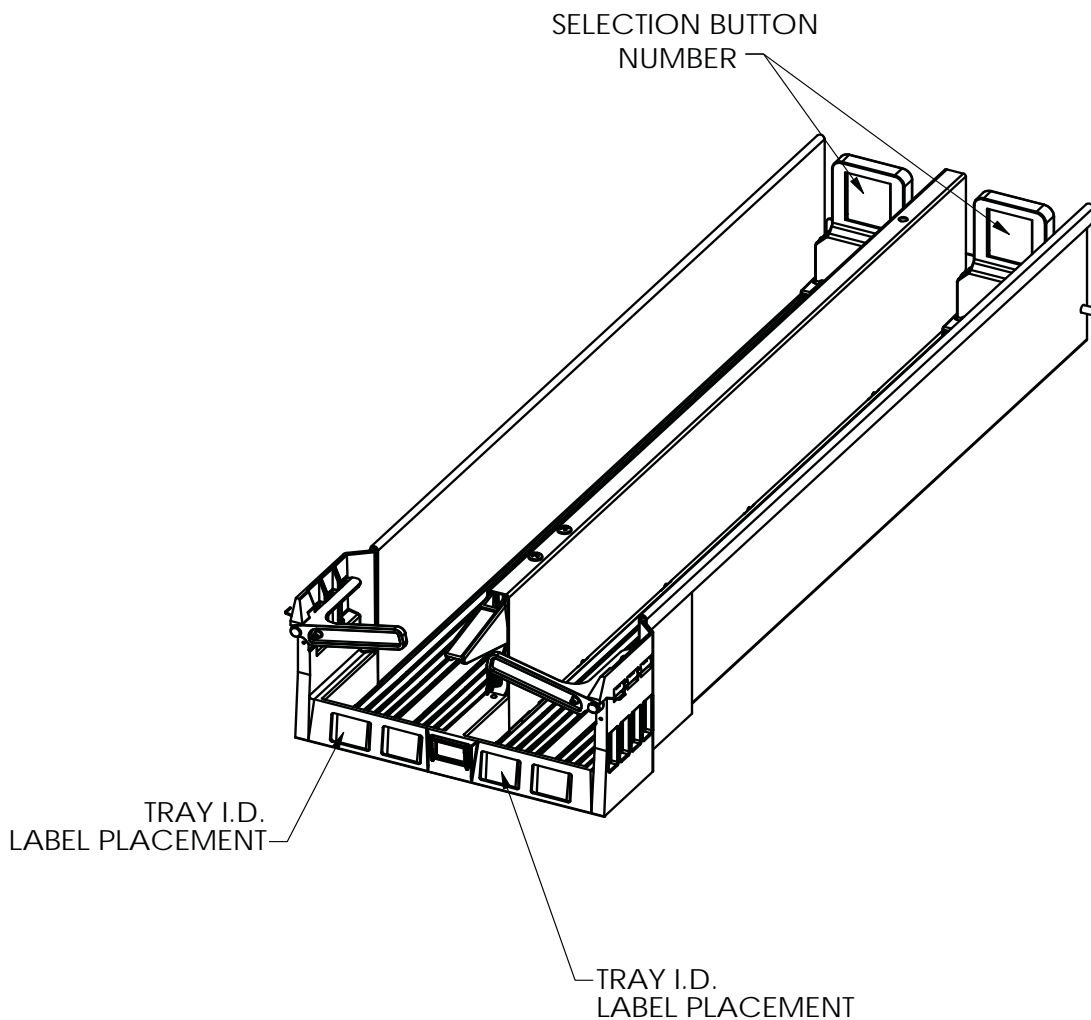

FIGURE 2

LOADING INSTRUCTIONS

1. Withdraw the tray from the cabinet by lifting slightly before pulling toward you. The tray will tilt down slightly to ease loading. Pull forward until the tray stop is reached.
2. Push the product pusher to the rear of the tray. The product pusher should lock into place in this position. Add new product to the tray. When the tray is pushed back onto the shelf, the product pusher will automatically unlock, and move to the back of the product queue. Ensure the tray is fully latched into position on the shelf.

It is suggested that one tray is loaded at a time, to maintain stability.

VEND MECHANISM PART DESCRIPTION

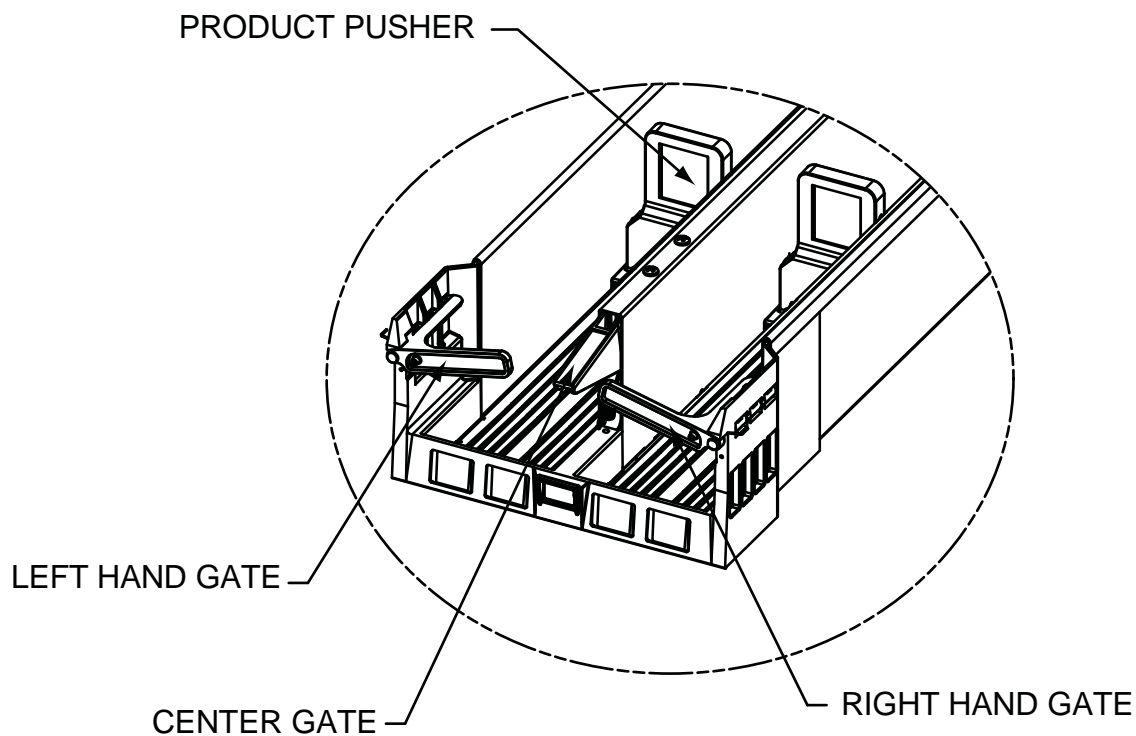

TRAY ASSEMBLY DETAIL

FIGURE 3

VUE VENDOR PART DESCRIPTION (CONTINUED)

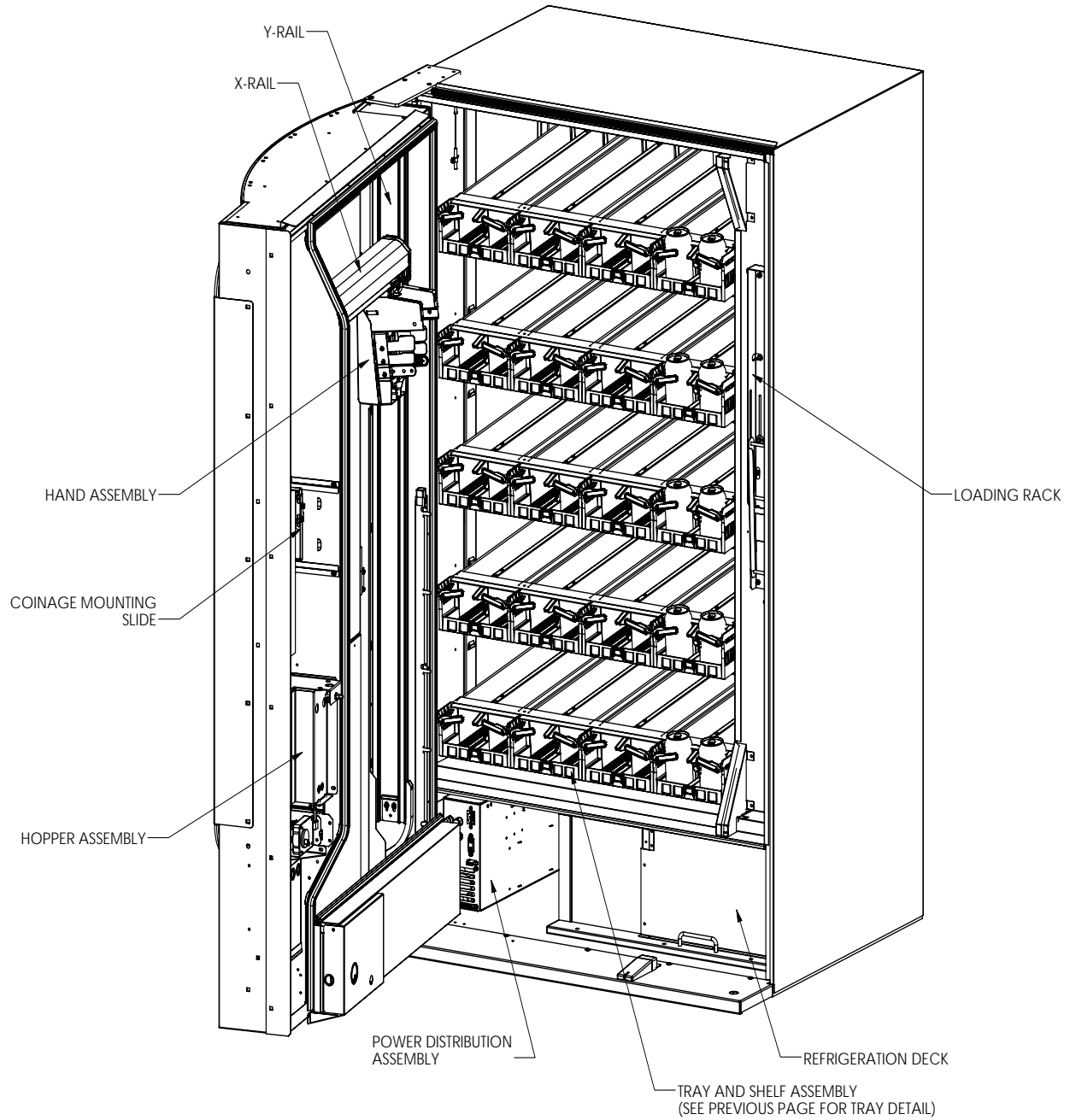

FIGURE 4



NOTES



SXY

CLEANING INFORMATION SECTION



CARE AND CLEANING

DO NOT USE WATER JET FOR CLEANING.

AVOID USING WATER OR ANY OTHER LIQUIDS NEAR ELECTRONIC COMPONENTS

- A. GENERAL PROCEDURE (painted metal areas)
Wash the vendor with soap and water. The exterior may be waxed with any good automobile wax.
- B. FRESH PAINT SPLASHES, GREASE, GLAZING COMPOUND REMOVAL
Before drying, these elements may be removed by rubbing lightly with grade "A" Naptha (or equivalent grade solvent). After removal, use general cleaning procedure (listed above in A).
- C. LABELS AND STICKER REMOVAL
Use any specialized label removal liquid. When the label material does not allow penetration of solvent (such as vinyl), the application of heat (ie – hot air gun) will soften the adhesive and promote removal. **CAUTION:** Excessive heat can cause surface damage. After the label is removed, use the general cleaning procedure (listed above in A).
- D. SCRATCH REMOVAL
Remove or minimize hairline scratches and minor abrasions in painted surfaces by using any good quality automobile polish. Test the polish before using.
- E. LEXAN SIGNS
To clean Lexan sign faces the following procedure is recommended.
1. Wash sign with mild soap or detergent and lukewarm water.
 2. Using a soft cloth or sponge, gently wash the sign. **DO NOT SCRUB!**
 3. Rinse well with clean lukewarm water.
 4. Dry thoroughly with a chamois or cellulose sponge (to prevent water spotting). **DO NOT USE SQUEEGEE!**
- NOTE:** Most organic solvents, petroleum, spirits, or alcohol are **NOT** compatible cleaning materials for Lexan signs. Usage of those materials could permanently damage the sign.



F. REFRIGERATION AREA

The condenser and evaporator must be kept clean for efficient operation. Be sure all vanes and tubing are clean and clear of obstruction; this allows free passage of air. Clean with a brush, a vacuum cleaner or compressed air, using extreme caution not to bend the condenser fins. Also note these fin edges can be sharp, so

Recommended Cleaning Schedule	
Vendor Area	Frequency
Product Flap	Monthly and when spills occur
Hopper/Delivery Port	Weekly and when spills occur
Exterior Cabinet/Door	Every 6 months or as needed
Lexan Signs	As needed
Cabinet Interior	Every 6 months or as needed
Door Interior	Every 6 months or as needed
Condenser	Every 3 months or as needed
Evaporator	As required
Trays/Slided	Every 6 months and when spills occur



NOTES



SXY

**VEC 15.4
PROGRAMMING SECTION**



VEC 15 PROGRAMMING OPERATION

NOTE: Some units may contain a European font display, in which case the “°” symbol will be replaced by the “β” symbol. Example: 72°F will be 72 β F.

The VEC 15.1 Controller uses a 4-button programming system:

Programming Buttons: # 1 – Exit/ Home
 # 2 – Increase/ Advance
 # 3 – Decrease/ Backup
 # 4 – Enter/ Save

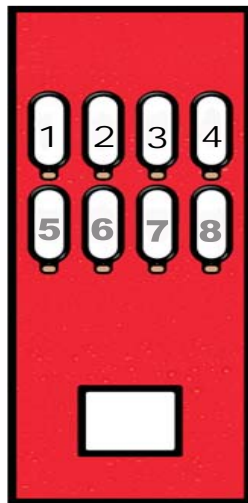

SXY30

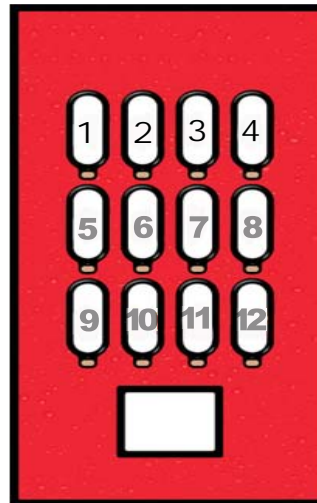

SXY40

*SXY30/40 Selection Button diagram

To access Mode functions, open the door. Locate the Mode Button (Page D-8) on the Main Control Board and press until Diagnostics appears. Use selection button 2 or 3 to navigate through the modes.

The Modes are as follows:

- Diagnostics
- Coin Payout
- Tube Fill
- Test Mode
- Calibration
- Password
- Cash Data*
- Sales Data*
- Set Price*
- Correct Change Only*



Discount Counter**
Free Counter**
Space to Sales*
Configuration*
Door Closed Password*
Set Language*
Set Clock ***
Lighting ***
Refrigeration ****
Sales Block 1-8 ***
Discount ***
Override *****
Custom Message*
Return

- * The options are in password protected mode. To access these features please scroll to Password, Press enter and press 2314.
- ** For the Discount Counter and/or Free Vend Counter to work, the option must be turned on and Set Clock Function must be activated and set. An override switch is required to activate the counters.
- *** These modes will only appear when the Timing Feature in Configuration is turned On.
- **** Limited options appear in this mode depending on whether the Timing Feature in Configuration is On/Off.
- ***** A secondary 'kit' is required for this option.

Note: Items that are in quotes, for example: “X Motor”, are what is displayed on the 20 character display:

Diagnostics:

Press Button 4 to enter Diagnostics Mode. If no errors have occurred, the display will read “Error None”. If an error code displays, enter the code using Button 4. Press Button 2 to advance through the ‘detailed summary’ of the individual error codes. To clear the errors, press and hold Button 4. The display will read “Error None”. To exit the Diagnostics Mode, press Button 1.

Coin Payout:

Coin Payout Mode allows the operator to ‘test’ for proper operation of the changer tubes.

1. Press Button 2 to scroll until “Coin Payout” is displayed.
2. Press Button 4 to Enter.
3. Advance on Button 2 to choose denomination.
4. Enter on Button 4 to dispense denomination displayed.
5. Exit on Button 1.

Tube Fill:

The changer coin tubes can be filled via the external coin insert plate or the acceptor part of the changer. This mode enables the Control Board to keep an accurate count of the coins.

1. Press Button 2 to scroll until “Tube Fill” is displayed.
2. Press Button 4 to Enter.
3. Insert coins through either the coin insert slot or acceptor part of the changer. The controller will display the ‘value’ and quantity of coins in the changer tubes.
4. Exit on Button 1.

Test Mode:

1. Press Button 2 to scroll until “Test Mode” is displayed.
2. Press Button 4 to Enter.

Test Mode Vending:

Up to twenty products can be vended in this mode.

1. Still in Test Mode, Press Button 2 to scroll until “Vending” is displayed.
- *2. Press Button 4 – Display will read ‘Close Door to Vend’.
3. Close outer door.
4. Display will read ‘Test Mode - Enter Selection’.
- *5. Press 1 to vend a selection. The vendor will sequence through its Test Space to Sales Configuration as shown in the Figure.

Drink Location for Test Vend:

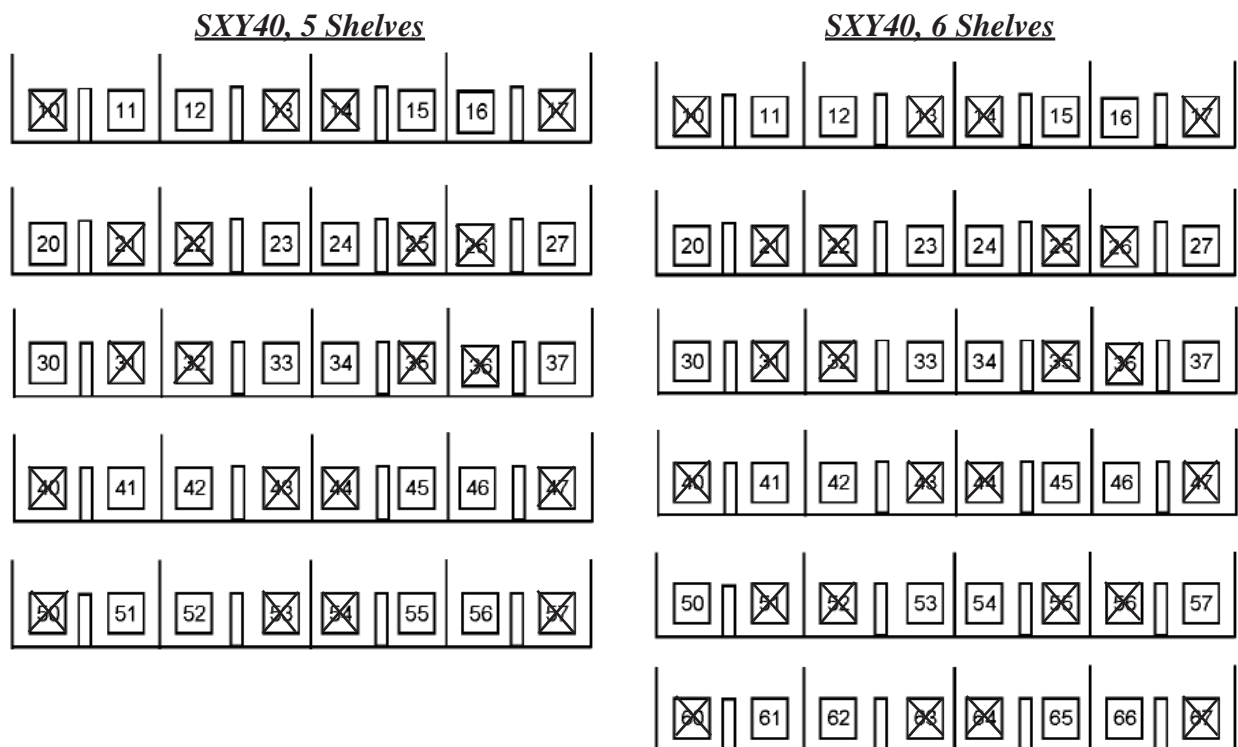

Drink Location for Test Vend:

SXY30, 5 Shelves

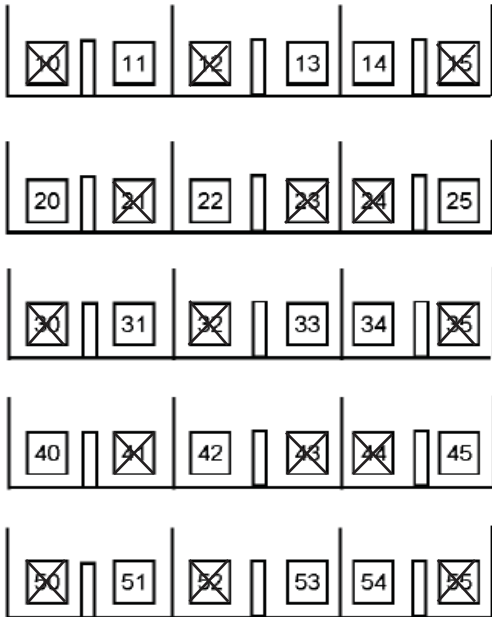

SXY30, 6 Shelves

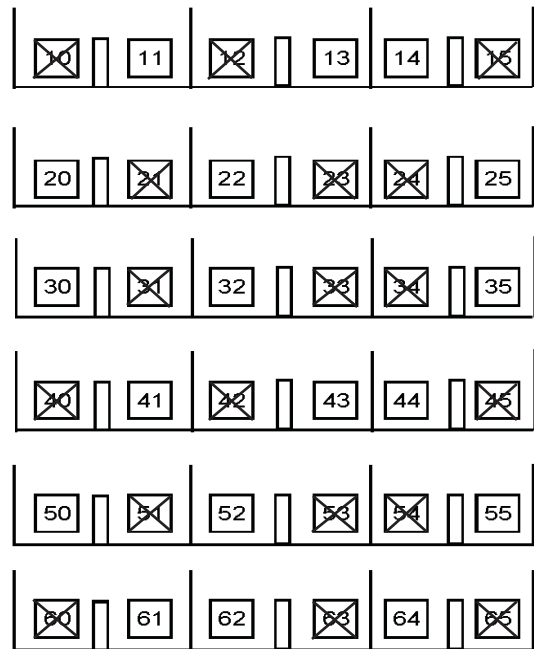

Test Mode Vend Specific Column:

1. Still in Test Mode, Press Button 2 to scroll until “Vend Specific Column” is displayed.
2. Press Button 4 to Enter.
3. Close outer door.
4. Display will read ‘Test Vend Column No. #XX’.
5. Press 2/3 to choose the column number, Press 4 to vend, Press 1 to Exit.
The vendor will revert back to sales mode if it is idle for 5 minutes.

Test Mode Test Hopper Flap:

1. Still in Test Mode, Press Button 2 to scroll until “Test Hopper Flap” is displayed.
2. Push Button 4 to Enter. – Testing in Progress –
3. Exit on Button 1.

Test Mode Test Hopper Bucket:

1. Still in Test Mode, Press Button 2 to scroll until “Test Hopper Bucket” is displayed.
2. Push Button 4 to Enter. – Testing in Progress –
3. Exit on Button 1.

Test Mode Test Vend Detection:

1. Still in Test Mode, Press Button 2 to scroll until “Test Vend Detection” is displayed
2. Push Button 4 to Enter – Display will read ‘Testing in Progress’ followed by:



STANDARD FONT DISPLAY

●●● – there is nothing blocking the optics, or ○○○ – optics are blocked.
EUROPEAN FONT DISPLAY

ΣΣΣ – there is nothing blocking the optics, or σσσ – optics are blocked.

Hopper Bucket will open to allow blocking/ unblocking of the optics.

3. Exit on Button 1.

Test Mode Test Motors:

After completion of work in Test Motors, please ensure that X, Y, Z and Clamp Motors have returned to the 'Home' position before closing the outer door.

1. Press Button 2 to scroll until “Test Motors” is displayed.
2. Press Button 4 to Enter.

Test Motors X Motor:

1. Still in Test Motors, Press Button 2 to scroll until “X Motor” is displayed.
2. Enter on Button 4 – ‘Pls wait...Entering Test Motors Mode’, followed by ‘Test Motors X Motor’ – Rail should move to the top of the vendor.
3. Enter on Button 4 – X Motor Go Home.
4. Enter on Button 4 – ‘Testing in Progress’ – Hand should move to the Lock side of the door.
5. Exit on Button 1.
6. Advance on Button 2 – ‘Go Opposite of Home’.
7. Enter on Button 4 – ‘Testing in Progress’ – Hand should move to hinge side of the door.
8. Press Button 1 twice to exit – Test Motors X Motor.

Test Motors Y Motor:

1. Still in Test Motors, Press Button 2 to scroll until “Y Motor” is displayed.
2. Enter on Button 4 – ‘Y Motor Go Home’
3. Enter on Button 4 – ‘Testing in Progress’ – Rail should move to the bottom of the door.
4. Exit on Button 1
5. Advance on Button 2 – ‘Y Motor Go Opposite of Home’
6. Enter on Button 4 – ‘Testing in Progress’ – Rail should move to top of door
7. Exit on Button 1 twice – ‘Test Motors Y Motor’

Test Motors Z Motor:

1. Still in Test Motors, Press Button 2 to scroll until “Z Motor” is displayed.
2. Enter on Button 4 – Calibration – Z Pos Z Cycle
3. Enter on Button 4 - Testing in Progress – Hand Clamp moves towards the shelves, pauses momentarily, then retracts.



4. Exit on Button 1 twice – Test Motors Z Motor

***** Note – Do not apply pressure to the ‘Arm’ as it could potentially jam. Power down vendor, wait 10 seconds, power on. Vendor should ‘Home’ any out of sync parts on the arm.**

Test Motors Clamp Motor:

1. Still in Test Motors, Press Button 2 to scroll until “Clamp Motor” is displayed.
2. Enter on Button 4 – ‘Clamp Motor Clamp Open’
3. Enter again on Button 4 – ‘Testing in Progress’ – the Fingers on the Hand should open

***** The Hand will not open if it is already open*****

4. Exit on Button 1
5. Advance on Button 2 – ‘Clamp Motor Clamp Close’

***** The Hand will not close if it is already closed*****

6. Enter on Button 4 – ‘Testing in Progress’ – The Fingers on the Hand Clamp should close
7. Press Button 1 twice to exit

Test Motor Get X Y Z Positions:

This is not applicable unless there is a problem. Please refer to the detailed instructions in the ‘Trouble Shooting Section’ of the Vue 30/40 Manual.

ALWAYS ENSURE THE CLAMP HAND HAS RETRACTED BEFORE CLOSING THE DOOR

Note – When you are in any Test Motor operation where the ‘HAND’ is Extended be sure to EXIT MODE on Button 1 before closing the Door

Test Mode Sensors Status:

Note: If the sensors are being replaced, press ‘4’ to refresh the sensor status.

1. Press Button 2 to scroll until “Sensors Status” is displayed.
2. Enter on Button 4 - Sensors Status display as follow:
STANDARD FONT DISPLAY

● – Inactive, or ○ – Active

EUROPEAN FONT DISPLAY

∑ – Inactive, or σ – Active

X	●	OR	○	-	X Home Sensor located on Z Housing
X	∑	OR	σ		
X	●	OR	○	-	Y Home Sensor located on the X Rail
X	∑	OR	σ		



X	●	OR	○	-	Z Home Sensor located on the PDC
X	∑	OR	σ		
X	●	OR	○	-	Hand Clamp Sensor located on the Hand
X	∑	OR	σ		
X	●	OR	○	-	Forward Looking Optics located on the top right corner of the Hand.
X	∑	OR	σ		

Note: If any ‘Reflectors’ are removed/ fall off of the Hinged or Lock Side of the vendor and it is a 5 shelf unit – it will fail the Discovery. In ‘Discovery’ they must be on all outside shelves. The middle shelves do not matter.

Test Mode Display:

1. Press Button 2 to scroll until “Display” is displayed.
2. Enter on Button 4
3. The 20 ‘boxes of pixels’ on each line should illuminate
4. Exit on Button 1

Test Mode Switches:

1. Press Button 2 to scroll until “Switches” is displayed.
2. Enter on Button 4
3. Activation of individual selection buttons (1 – 12) for SXY40, (1 – 8) for SXY30 should display
4. To Exit, press and hold Button 1 for 5 seconds or until Display returns to ‘Test Mode Switches’

Test Mode Relays:

This Mode allows you to test the following relays:

1. Compressor
2. Fluorescent Light
3. Heater
4. Fan

1. Press Button 2 to scroll until “Relays” is displayed.
2. Enter on Button 4.
3. Enter on Button 4 – Compressor ‘Off’
4. Enter again on Button 4 – ‘Off’ flashes
5. Advance on Button 2 – ‘On’ flashes
6. Enter on Button 4 – Compressor should turn ‘on’ if relay is functional
7. Exit on Button 1 – Compressor will default back to ‘Off’

Repeat steps 1 through 5 for desired relay. To exit ‘Test Mode’ and return to the Main Menu, press Button 1 three times.



Calibration:

Calibration PDC Software Maintenance:

The PDC Maintenance Position Mode should only be accessed if a chip needs to be replaced in the Hand. Please refer to the 'Trouble Shooting Section' of the Vue 30/40 Manual.

1. Press Button 2 to scroll until "Calibration" is displayed.
2. Press Button 4 to Enter.
3. Enter on Button 4 – Maintenance 'Off'
4. Press Button 4 – 'Off' flashes
5. Advance on Button 2 – 'On' flashes
6. Save on Button 4 – Hand should extend for access to the Control Board

***** After completion of work in 'Calibration PDC Software Maintenance', ensure that X, Y, Z and Clamp Motors have returned to the 'Home' position - Power down vendor, wait 1 minute then Power on vendor BEFORE closing the outer door. It will perform a Recovery/Discovery automatically. *****

Calibration Discovery:

Please refer to the Levels and explanations listed below:

- Level – 0 We are not doing a 'Discovery – no motion. No Discovery is required
- Level – 1 Check Physical Shelves against the stored data. If shelf is in stored data, is there a reflector that corresponds to it
- Level – 2 Sets vendor for actual physical locations for trays and shelves

1. Press Button 2 to scroll until "Discover" is displayed.
2. Enter on Button 4 – 'Discovery Level 0'
3. Advance on Button 2 to desired level
4. Press Button 4 to save
5. If Level 1 or 2 is chosen, the display will read 'Please close the door' followed by 'Press 1 – Accept'
6. Press Button 1 to start the Discovery process
7. Vendor will return to 'Sales Mode' when Discovery has been completed.

*** Note: Calibration Menus are Password protected. Please contact Technical Service: 1-800-344-7216 for assistance in changing vendor configuration.**

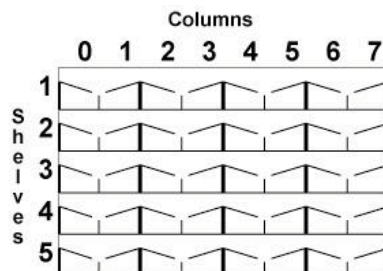



Calibration Discovery Correction:

Allows the user to alter vending positions in X and Y for the entire vendor, a particular shelf or a particular tray set. **This mode is used in Trouble Shooting only.**

For Shelves and Columns use this diagram:

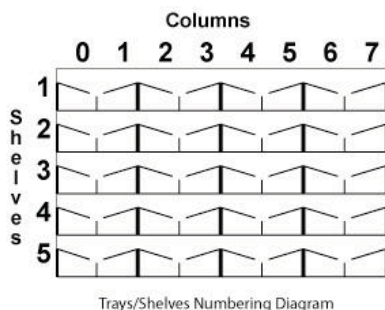

For Tray Numbers use this diagram:

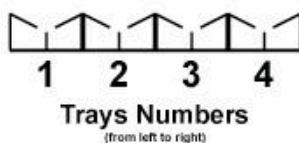

Calibration Test Vend-No pdt:

Allows the vendor to do a self- test of all positions including running the Hopper Flap and Hopper Bucket.

1. Press Button 2 to scroll until “Password” is displayed.
2. Enter the password, 2582.
3. Press Button 4 to enter.
4. Press Button 2 to scroll until “Test Vend” is displayed.
5. Enter on Button 4 – Calibration – Test Vend No pdt Off
6. Enter on Button 4 again – Off flashes
7. Advance on Button 2 to On
8. Press Button 4 to ‘save’ setting – Display will read - Please close the Door followed by Press 1 – Accept, 8 - Cancel
9. Press Button 1 to start the Test Vend process

Calibration Get Failures:

While self-testing, the PDC creates a log of errors it encounters. This function allows you to step through these errors. For each location on the shelf ● OR ∑ indicates success while ○ OR σ indicates a failure.

Example: | ●● | ●● | ●● | ●● | - STANDARD FONT DISPLAY

| ∑ ∑ | ∑ ∑ | ∑ ∑ | ∑ ∑ | - EUROPEAN FONT DISPLAY



1. Press Button 2 to scroll to shelves to view any failures
2. Press Button 1 to exit

Cash Data:

This Mode allows you to retrieve the total Historical Cash from product purchases.

1. Press Button 2 to scroll until "Password" is displayed.
2. Enter on Button 4.
3. Press 2314 and Press Button 4 to Enter.
4. Press Button 2 to scroll until "Cash Data" is displayed.
5. Enter on Button 4 – the non re-settable, Historical Cash Total will scroll
6. Advance on Button 2 to scroll through the shelves
7. Enter on Button 4 to show the columns in the shelves
8. Press Button 1 to exit.

Sales Data:

This Mode allows you to retrieve the total Historical Sales from product purchases.

1. Push Button 2 to scroll until "Sales Data" is displayed.
2. Enter on Button 4 – the non re-settable, Historical Sales Total will scroll
3. Advance on Button 2 to scroll through the selections
4. Enter on Button 4 to show the columns in the shelves
5. Press Button 1 to exit.

Set Price:

This Mode allows you the option to price each selection to the same vend price, or price each shelf, tray or column. (*Refer to diagram on next page*)

To set all selections to a 'single price':

1. Press Button 2 to scroll until "Set Price" is displayed.
2. Enter on Button 4 – Display will read - "Set Price All Selection --.--" or "Set Price All Selections (Current vend price)"
3. Enter again on Button 4 – (current vend price) will flash
4. Advance on Button 2 to increase the price
5. Press Button 3 to decrease the price
6. Press Button 4 to save change
7. Press Button 1 to exit.

To set price per Selection Button:

1. Enter on Button 4 – Set Price - All Selection
2. Press 2 to scroll to Button X
3. Enter on Button 4 - Button X - (Price) flashes
4. Advance on Button 2/ decrease on Button 3 to desired price
5. Press Button 4 to save change – Button X - (Price)
6. Advance to next on 2 – Set Price – Button X
8. Set prices following steps outlined



9. Exit on Button 1 to return to Set Price

Correct Change Only:

1. Push Button 2 to scroll until “Correct Change Only” is displayed.

Correct Change Only - Customer Overpay:

On - Money will be accepted when the ‘Use Exact Change’ display is on and there is insufficient coin in the coin tubes.

Off - Exact change only required to make a vend.

Correct Change Only - Correct Change:

This is the amount the VMC will use to control the Use Exact Change message.

Correct Change Only - Accept Value:

The largest value of any single form of currency that can be accepted without the knowledge that the equivalent value of coins can be returned.

Space to Sales:

1. Press Button 2 to scroll until “Space to Sales” is displayed.

2. Prss Button 4 to Enter.

Default On/Off: This is the default configuration to show the relation between the Selection Button and the columns in the vendor. When set to On, the default will be set as per the number of trays. The following plan-o-gram shows the default STS in a Vue30/Vue 40 vendor.

SXY40 Space to Sales - Plan-o-gram

Shelf A	1,10 10	1,10 11	1,10 12	1,10 13	1,10 14	1,10 15	1,10 16	1,10 17
Shelf B	2 20	2 21	2 22	2 23	3,11 24	3,11 25	3,11 26	3,11 27
Shelf C	4 30	4 31	4 32	5,12 33	5,12 34	5,12 35	5,12 36	5,12 37
Shelf D	6 40	6 41	6 42	7 43	7 44	7 45	5,12 46	5,12 47
Shelf E	8 50	8 51	8 52	9 53	9 54	9 55	3,11 56	3,11 57

Selection Button	Brand	# of Columns	% of Inventory
1	Coca-Cola	8	20%
2	Coke Zero	4	10%
3	Diet Coke	4	10%
4	Sprite	3	8%
5	Dasani	7	18%
6	Regional Brand 1	3	8%
7	Regional Brand 2	3	8%
8	Regional Brand 3	3	8%
9	Regional Brand 4	3	8%
10	Coca-Cola		0%
11	Diet Coke	2	5%
12	Dasani		0%
		40	

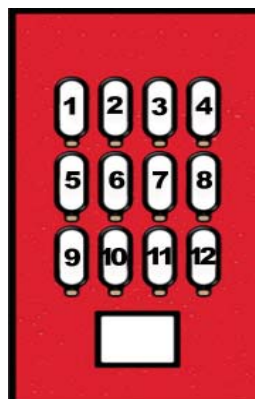

SXY30 Space to Sales - Plan-o-gram

Shelf A	1,8 10	1,8 11	1,8 12	1,8 13	1,8 14	1,8 15
Shelf B	3 20	3 21	3 22	3 23	3 24	1,8 25
Shelf C	2 30	2 31	2 32	4 33	4 34	4 35
Shelf D	5 40	5 41	5 42	5 43	5 44	5 45
Shelf E	6 50	6 51	6 52	7 53	7 54	7 55

Selection Button	Brand	# of Columns	% of Inventory
1	Coca-Cola	7	18%
2	Coke Zero	3	8%
3	Diet Coke	5	13%
4	Sprite	3	8%
5	Dasani	6	15%
6	Regional Brand 1	3	8%
7	Regional Brand 2	3	8%
8	Coca-Cola	30	0%



Custom: This allows the vendor to be programmed to connect any selection buttons to any columns in the machine.

Space to Sales - Custom Clear:

This allows the user to clear the individual buttons from any column on the vendor.

1. Enter on Button 4 - Display reads “Clear All? Yes-4 No-3”. Press 3 to clear individual selection or 4 to clear all locations.
2. To Clear - Press the column number and then the button #, i.e. to clear Column 11 from Button 4 - Press 1,1 and 4. Display reads “Del CL# 11 to Btn# 4”. Please use button 10 for zero in a 4 tray machine (Vue 40) and Button 6 on a three tray machine (Vue 30), i.e. to clear 10 from button 3 - Press 1, 10 and 3.
3. Repeat Step to clear other columns from any button. Note: To clear the shelf from a button - Press X8 and the button number. X is the shelf number, i.e. to clear shelf 3 from button 8 - Press 3,8 and 8.
4. To Exit - Press and hold any button for 2 seconds.

Space to Sales - Custom Set:

This allows the user to connect the individual buttons to any columns on the vendor.

1. Enter on Button 4 - Display reads “Set CSTS - CL# -- Btn# ___”.
2. To Set - Press the column number and then the button #, i.e. to set Column 11 to Button 4 - Press 1,1 and 4. Display reads “Add CL# 11 to Btn# 4”. Please use button 10 for zero in a 4 tray machine (Vue 40) and Button 6 on a three tray machine (Vue 30), i.e. to connect 10 to button 3 - Press 1, 10 and 3.



3. Repeat Step to connect other columns to any button. Note: To connect the shelf to a button - Press X8 and the button number. X is the shelf number, i.e. to connect shelf 3 to button 8 - Press 3,8 and 8.
4. To Exit - Press and hold any button for 2 seconds.

Space to Sales - Custom Dsp/Edit:

This allows the user to view and edit the current Space to Sales.

1. Enter on Button 4.
2. To scroll press 2 or 3 - The Column number will be displayed and the corresponding button(s) will flash. If there are no buttons connected with the column "None" will flash.
3. To add/delete press and hold the selection button for 1 second - The display will indicate Btn XX added or Btn XX deleted.
4. To Exit - Press 1. To save any changes press until display reads "Save Settings? Yes-4 No-3".

Note: Discount Counter and/or Free Counter will only appear when the Timing Feature in Configuration is turned On.

Discount Counter:

This Mode will only display when 'Discounts' are used. It allows access to the Sales and Cash Data for discounted vends.

1. Enter on Button 4 – 'Cash Data'
2. Enter again on Button 4 – Display will read 'Cash Data Total' and display the value of all discounts towards paid sales. This total is non re-settable and begins when the 'Discount' feature is enabled.
3. Advance on Button 2 to scroll through the various selections
4. Press Button 1 to exit
5. Advance on Button 2 – 'Sales Data'
6. Enter on Button 4 – 'Sales Data Total' will display as well as the number of discounted sales. This total is non re-settable and begins when the 'Discount' feature is enabled
7. Advance on Button 2 to scroll through the various selections
8. Press Button 1 to exit.

Free Counter:

This Mode will only display when 'Free Vends' were made. It allows the user access to the number of 'Free Sales and Cash Data' lost.

1. Enter on Button 4 – Cash Data total XX.XX, which is the value of the money lost based on the set price. This total is non re-settable and begins when the 'Free Vend Override' is enabled.
2. Advance on Button 2 – 'Sales Data Total X', which is the total number of products dispensed. This total is non re-settable and begins when the 'Free Vend Override' is enabled.
3. Press Button 1 to exit.

Clearing the Cash Data, Sales Data, Discount Counter or Free Counter:



*To reset the individual selection counter, scroll to the selection number, press and hold buttons # 1 and 4 for 3 seconds, **0000 will display**. You can also set 'MIS Auto Reset ' to 'On' under 'Configuration'*

Configuration:

To change individual options for Configuration Settings, enter the option on Button 4. Re-enter on Button 4, 'On or Off' will be flashing. Advance to 'On or Off' on Button 2 and save the change on Button 4. Program each Configuration Option in this manner.

Configuration Options are detailed below:

Multi-Price:

- On – Selections may be programmed individually
- Off – Single Price based on price of Selection 1

Timing Features:

- On - Access to 'Clock Settings' and associated modes
- Off – Access is denied

Door Summary:

- On - Sales, Cash and Errors are displayed when outer door is opened
- Off – Sales and Cash are not displayed, error summary will be

MIS Auto Reset:

- On - Pressing the Door Switch will reset individual selection data back to 0
- Off – Sales and Cash Data will not be reset by the Door Switch

Save Credit Timer:

- On - Credit established will display for 5 minutes only
- Off – Credit established will remain until either a vend is made or the coin return is pressed.

Force Vend:

- On - The consumer will not be able to deposit money, press the coin return and receive change without attempting a vend first.
- Off – Vendor is set as a 'change' machine. Consumer can deposit money, press the coin return and receive change.

Multi-Vend:

- On - The consumer may insert sufficient credit to make multiple purchases. Remaining credit will display until consumer either makes another selection or presses the coin return.
- Off – Consumer makes a single purchase and change is returned immediately.

Deny Escrow:

- On - Validator will stack all bills received
- Off – Validator will 'hold' the bill in 'escrow' until the vend is complete. if the consumer presses the coin return the 'bill' is returned to them.

S/O (Error) Indicator:

- On - A small symbol - (♦) will appear in the lower right hand corner of the display when the vendor detects an error or a sold out column.
- Off – The symbol will not appear.



Count by Selection/Price:

Count by Selection – Individual Sales and Cash Data are displayed.

Count by Price – Individual Sales and Cash Data is reported by vend price.

MIS Reset with DEX:

On - Non-Historical MIS Data will reset when a DEX read has been done.

Off – No MIS Data will be reset.

Double Talk: - This is a kit supplied by a third party source**

On - Module will vocalize messages.

Off – Module will not vocalize messages.

Display Scroll:

On - Messages ‘Scroll’ from left to right side of display.

Off – Messages do not scroll.

Display Temperature:

Off – Cabinet temperature will not display.

Ref – Internal Refrigeration Temperature will display as ‘Refrigeration Temperature’.

Cbt – Internal Cabinet Temperature will display as ‘Cabinet Temperature’. **

** Note: Requires Temperature Lockout Kit in order to display

Vend Protect:

On – The ‘Hand’ will stay next to the flap until product is removed/ bucket closes.

Off – The ‘Hand’ will return to the ‘Home’ position after product is delivered to the vend flap.

PDC Wait Time: (Available only in VMC Rev. 1.20 and PDC Rev. 1.16)

Default: 30s

Off/15s/30s/45s/45s/60s - PDC waiting time at the center after a vend.

Set # of Trays:

Allows the operator to ‘choose’ the number of ‘Trays’ in the vendor.

1. Enter on Button 4 - ‘Set # of Trays 3, 4, or 5’
2. Enter on Button 4 - ‘3, 4, or 5’ is flashing
3. Advance on Button 2 to desired Tray Setting that matches the vendor
4. Press Button 4 to ‘save’ setting
5. Press Button 1 to send the new setting to the Main Controller.

*** Number of Trays MUST match the Vendor ***

Set Z pdt Position:

Allows the operator to adjust the depth that ‘Z’ goes into the vendor to retrieve product.

1. Press 2 to scroll until “Z pdt” is displayed.
2. Enter on Button 4 - ‘Set Z pdt Position’. Current position is shown.
3. Enter on Button 4 - Current position is flashing
4. Advance on Button 2 to desired product position
5. Press Button 4 to ‘save’ setting
6. Press Button 1 to send the new setting to the Main Controller.



Set Column Depth:

Allows the operator to adjust the number of products in a column. This vendor will count the number of successful vends from a selection and set the column as soldout once the set depth value has been reached.

Setting Depth for all Selection

1. Enter on Button 4 - 'Set Column Depth - All Selection'.
2. Enter on Button 4 - Current Depth is flashing
3. Advance on Button 2 to desired column depth
4. Press Button 4 to 'save' setting

Setting Depth for Individual Selection Button

1. Enter on Button 4 - 'Set Column Depth - All Selection'
2. Scroll on 2 to individual button.
3. Enter on Button 4 - Current Depth is flashing
4. Advance on Button 2 to desired column depth
5. Press Button 4 to 'save' setting
6. Press Button 1 to Exit.

DEX Version: (Available only in VMC Rev. 1.20 and PDC Rev. 1.16)

Default: Trade

Trade/Coke/Pepsi - Options for machine type

Door Closed Password:

Allows the operator to set a password to access Sales Data when the door is closed. **This function does not work when vend price is set at 0.00 **

1. Exit to Menu. Press Button 2 until "Door Closed Password" is displayed.
2. Enter on Button 4 – current 'Password' will display with the 1st digit flashing indicating that it is ready to be edited
3. Press Buttons 2 and 3 to change the digits. NOTE: Valid digits are 1 through 6. The Password 0000 will disable this feature.
4. Press Button 4 to save digit and advance to the next.
5. Press Button 4 after 4th digit is assigned – Door Closed Password will display.
6. Press Button 1 to Exit.

** Do not close door prior to programming all 4 digits of the password.

Set Language:

The current Languages available for programming are: English, Spanish and French.

1. Press Button 2 to scroll until "Set Language" is displayed.
2. Enter on Button 4 – current language will display
3. Enter on Button 4 again – current language flashes
4. Advance on Button 2 to desired language
5. Press Button 4 to save
6. Press Button 1 to exit.



Set Clock:

When the 'Timing Features' in Configuration Mode is turned 'On', this Clock can be set.

1. Enter on Button 4 at Set Clock – Enable Off will display (If no prior programming was done)
3. Enter on Button 4 – Off will flash
4. Press Button 2 to advance Off to On
5. Press Button 4 to save setting
6. Advance on Button 2 – 'Daylight Savings'
7. Enter on Button 4 – current setting will display
8. Press Button 4 – current setting flashes
9. Advance on Button 2 to desired setting
10. Press Button 4 to save setting
11. Press Button 1 to exit Daylight Savings
12. Advance on Button 2 - MM/DD/YYYY HH:MM will display
13. Enter on Button 4 – MM flashes (month)
14. Advance on Button 2 to correct month
15. Press Button 4 to 'save' – DD flashes (day)
16. Advance on Button 2 to correct day
17. Press Button 4 to 'save' – YYYY - with YY flashing (last 2 digits of year)
18. Advance on Button 2 to correct year
19. Press button 4 to 'save' – HH flashes (hour)
20. Advance on Button 2 to correct hour
21. Press Button 4 to 'save' – mm flashes (minutes)
22. Advance on Button 2 to correct minutes
23. Press Button 4 to save setting – MM/DD/YYYY HH:MM will display
24. Press Button 1 to exit - Set Clock

Lighting:

'Timing Features' in Configuration Mode must be turned 'On' to access this feature. You have the option to turn the lights or LED off once during a 24-hour period for energy conservation. The options available are Cabinet and LED.



Example:

Lighting Mode – Enable On/ Off
Lighting – Cabinet
Start Time 1 – Start Day 1 – Mon-Sun/Everyday
Start 1 hh:mm
Stop Time 1 – Stop Day 1 – Mon-Sun/Everyday
Stop 1 hh:mm

Lighting – LEDs
Start Time 2 – Start Day 2 – Mon-Sun/Everyday
Start 2 hh:mm
Stop Time 2 – Stop Day 2 – Mon-Sun/Everyday
Stop 2 hh:mm
* On – associated with a programmed start/stop
* Off – not associated with a programmed start/stop

1. Press Button 4 – ‘Lighting – Mode Enable Off (if no prior program was set)
2. Press Button 4 – Off is flashing
3. Advance on Button 2 – On
4. Press Button 4 to save setting – Lighting – Mode Enable On
5. Press Button 4 to ‘save’
6. Advance on Button 2 – Lighting Cabinet
7. Advance again on Button 2 – Lighting LEDs

To Set Lighting Cabinet or Lighting LEDs:

1. Press Button 4 to enter – Start Time 1(Lighting) or Start Time 2 (LEDs)
2. Press Button 4 again – Start Day 1 or 2 – Mon-Sun-everyday Off/On
3. Press Button 4 again – Off/On flashes
4. Press Button 2 to scroll between On/Off
5. Press Button 4 to save setting
6. Press Button 1 - Start Day 1 or 2
7. Advance on Button 2 - Start 1: 08:00 (if no prior programming was set – hh:mm)
8. Enter on Button 4 at ‘Start 1 or 2 - the 08 flashes (hour)
9. Advance on Button 2 to desired setting
10. Press Button 4 to save – :00 begins flashing (minutes)
11. Advance on Button 2 to desired setting
12. Press Button 4 to save setting – Start 1 or 2 and hh:mm you programmed will display
13. Press Button 1 - Start Time 1or 2
14. Press Button 2 to advance to Stop Time 1or 2
15. Press Button 4 – Stop Day 1 or 2
16. Press Button 4 – Stop Day 1 or 2 – Mon-Sun-everyday Off/On
17. Repeat above steps for Stop Time 1or 2



Refrigeration:

If ‘Timing Features’ in Configuration Mode are ‘Off’, you will only have access to the following features:

Set point

Sensor Reading

Degree X – Celsius or Fahrenheit

Fan Default

Periodic Defrost – On/Off

When Timing Features is set on in Configuration, you can raise the cabinet temperature 18 °F/ 4°C twice during a 24 hour period for energy conservation.

Refrigeration:

1. Press Button 1 to exit until you see main menu
2. Press Button 2 to scroll until “Refrigeration” is displayed
3. Enter on Button 4
4. Enter on Button 4 – ‘Set Point’
5. Enter on Button 4 – current ‘Set Point’ will display – (Factory setting is 36°F/2°C)
6. Press Button 4 – current temperature will flash
7. Press Button 2 or 3 to scroll through the following settings:

Temperature setting	32	33	34	35	36	37	38	39	40
Cut-in Temperature (F)	34	35	36	37	38	39	40	41	42
Cut-out Temperature (F)	31	32	33	34	35	36	37	38	39
Nominal Temperature (F)	32	33	34	35	36	37	38	39	40
Nominal Temperature ©	0	0.5	1	1.5	2	2.5	3	3.5	4

5. Press Button 4 to ‘save’ desired setting
7. Press Button 1 to exit – Set Point
8. Advance on Button 2 – Sensor Reading
9. Press Button 4 – Current reading in either F/C will display – must be set as Ref in Configuration first.
10. Press Button 1 – Sensor Reading
11. Advance on Button 2 – Degree F/C
12. Enter on Button 4 – current setting flashes
13. Press Button 2 to scroll between F/C
14. Press Button 4 to save desired setting

Fan Default:

Default Mode: Fan on/off behaves in same respect as the compressor.

Mode 1: Fan is time delayed with compressor cut in/cut out

1. At cut in, fan will come on 1 minute after compressor turns on
2. At cut out, fan will continue to run 1 minute after compressor is off



3. Fan off with door switch activation

Periodic Defrost:

1. Press Button 4 – On/Off
2. Press Button 4 – On/Off flashes
3. Advance on Button 2 to desired setting
On – The vendor will defrost every 6 hours for 30 minutes. This feature is used in extremely high humidity environments.
Off – The vendor will not defrost every 6 hours.
4. Press Button 4 to ‘save’ setting
5. Press Button 1 to exit to Main Menu

When ‘Timing Features’ in Configuration are turned ‘On’, the following Modes are accessible:

Refrigeration – Enable Timer On/Off
Start Time – Start Day 1/2 – Mon-Sun/All
Start hh:mm
Stop Time – Stop Day 1/2 – Mon-Sun/All
Stop hh:mm

Enable Timer:

1. Press Button 2 or 3 to scroll until “Enable Timer” is displayed
2. Press Button 4 – On/Off flashes
3. Advance on Button 2 to desired setting
4. Press Button 4 to ‘save’ setting
5. Press Button 2 – Start Time 1. Time Refrigeration turns off/begin conservation
6. Press Button 4 – Start Day 1
7. Press Button 4 - current setting appears
8. Press Button 4 – current setting flashes
9. Press Button 2 or 3 to scroll through days of the week or ‘Every Day’
10. Press Button 4 – On/Off flashes
11. Advance on Button 2 to desired setting
12. Press Button 4 to ‘save’ setting
13. Press Button 1 to exit – Start Day 1
14. Press Button 2 to advance to Start 1 hh:mm
15. Press Button 4 at Start 1 hh:mm – hh flashes
16. Press Button 2 to set the hh
17. Press Button 4 to ‘save’ setting – mm flashes
18. Press Button 2 to set: mm
19. Press Button 4 to ‘save’ setting
20. Press Button 1 to exit – Start Time 1
21. Advance on Button 2 – Stop Time 1
22. Enter on Button 4
23. Follow the steps outlined above to complete Stop Time 1, Start Time 2, Stop Time 2
24. Press Button 2 to advance



TempLO (Temperature Lock Out):

1. Enable timing feature in configuration
2. Advance on button 2 to TempLO shelf 1
3. Press Button 4 – Disable will flash
4. Advance on Button 2 – Enable
5. Press Button 4 to ‘save’ setting
6. Continue in above manner for all shelves associated with Temperature Lockout

Note: The Temperature Lockout Feature (TempLO) requires an additional temperature sensor connected at the top left on the inside of the cabinet. When the cabinet temperature is above 41°F/ 3.5 °C for more then 15 minutes, the vendor will shut down any shelves associated with the Temperature Lockout Feature.

Sales Block: (8 Blocks are available in this Mode)

‘Timing Features’ in Configuration Mode must be turned ‘On’ to access this feature. Sales Block allows the operator to turn Selections On/Off at 8 intervals during a 24-hour period. Times must not overlap. You must enter the following information:

Selections – the selection buttons that will be disabled during the blocked time

Start Time – the time selections will be ‘Off Line’

Start Days – the days selections will be ‘Off Line’

Stop Time – the time selections will turn back ‘On’

Stop Days – the days selections will turn back ‘On’

Sales Block 1:

1. Press Button 4 - Enable On/Off, Light
 - Enable Off – Block Function is disabled
 - Enable On – Block Function is enabled
 - Enable Light – Block Function is enabled and lights are off when blocking occurs
2. Press Button 4 – On/Off Light flashes
3. Press Button 2 to advance to desired setting
4. Press Button 4 to ‘save’ setting – your choice will display
5. Press Button 2 to advance to – Selections

Choose Selections:

1. Press Button 4 at Selections – All Selections On/Off will display
2. Press Button 4 – On/Off flashes
3. Advance on Button 2 to desired setting
4. Press Button 4 to ‘save’ setting
5. Press Button 1 to exit

Set all Selections:

1. Press Button 4 – All Selections On/Off
2. Press Button 4 – On/Off flashes



3. Press Button 2 to advance to desired setting
4. Press Button 4 to 'save' setting
5. Press Button 1 to exit – Selections

Selections per Shelf:

1. Press Button 4 – All Selections On/Off
2. Press Button 2 to advance to desired shelf
3. Press Button 4 – All Columns
4. Press Button 4 again – On/Off flashes
5. Press Button 2 to advance to On/Off
6. Press Button 4 to 'save' setting
7. Press Button 1 twice to exit – Selections

Set Columns:

1. Press Button 4 – All Selections On/Off
2. Press Button 2 to advance to desired shelf
3. Press Button 4 – All Columns
4. Press Button 2 to advance to desired Column
5. Press Button 4 – On/Off flashes
6. Press Button 2 to advance to desired setting
7. Press Button 4 to 'save' setting
8. Press Button 1 twice to exit

Start Time: (Beginning of Blocking Period)

1. Press Button 2 – Start Time
2. Press Button 4 – Start Day
3. Press Button 4 – Every Day
4. Press Button 2 or 3 to select days or Every Day
5. Press Button 4 to change the status of the days – On/Off flashes
If the status is 'On', product delivery is blocked
If the status is 'Off', product delivery is normal
6. Press Button 2 to change status
7. Press Button 4 to 'save' setting
8. Press Button 1 – Start Day
9. Press Button 2 – Start hh:mm
10. Press Button 4 – hh (hour setting) flashes
11. Press Button 2 to advance to desired Start Hour. (Military Time)
12. Press Button 4 to 'save' setting -: mm flashes
13. Press Button 2 to advance to desired minutes
14. Press Button 4 to 'save' setting
15. Press Button 1 to exit and return to Start Time

Stop Time: (End of Blocking Period)

1. Advance on Button 2 – Stop Time



2. Press Button 4 – Stop Day
3. Press Button 4
4. Press Button 2 or 3 to select days or Every Day

5. Press Button 4 to change the status of the days – On/Off flashes
If the status is ‘On’, product delivery is blocked
If the status is ‘Off’, product delivery is normal
6. Press Button 2 to change status
7. Press Button 4 to ‘save’ setting
8. Press Button 2 – Stop hh:mm
9. Press Button 4 – hh (hour setting) flashes
10. Press Button 2 to advance to desired Start Hour. (Military Time)
11. Press Button 4 to ‘save’ setting -: mm flashes
12. Press Button 2 to advance to desired minutes
13. Press Button 4 to ‘save’ setting
14. Press Button 1 to exit and return to Stop Time
15. Pressing Button 1 again will return the operator to Sales Block 1-8 mode

Discount:

‘Timing Features’ in Configuration Mode must be turned ‘On’ to access this feature. This feature permits the operator to program the vendor to discount product once during a 24-hour period. To program a Discount, you must enter the following information:

Discounted Selection(s) – Selection(s) offered at a discounted price
Start Time – Time the Discount begins
Start Day(s) – Days the Discount is offered
Stop Time – Time(s) Discount ends
Stop Day – Day(s) the Discount ends
Amount – Amount subtracted/discounted from original vend price

Choose Selections:

1. Press Button 4 – Enable On/Off
Enable Off – Discount function is disabled
Enable On – Discount function is enabled
2. Press Button 4 – Off flashes
3. Press Button 2 to select desired setting
4. Press Button 4 to ‘save’ setting – Enable ‘On’ will display
5. Press Button 2 – Discounted Selection

Set Discount for ‘All’ Selections:

1. Press Button 4 – Discount all selections ‘Off’
3. Press Button 4 – ‘Off’ flashes
4. Press Button 2 to Advance to ‘On’
5. Press Button 4 to ‘save’ setting



6. Press Button 1 to exit

Set Discounted Selections per Shelf:

1. Press Button 4 – Discount All Selections ‘Off’
2. Advance on Button 2 to desired shelf number
3. Press Button 4 to enter – Shelf X - All Columns ‘Off’
4. Press Button 4 – On/Off flashes
5. Advance on Button 2 to desired setting
6. Press Button 4 to ‘save’ setting
7. Press Button 1 to exit

Start Time:

1. Advance on Button 2 – Discount Start Time
2. Press Button 4 – Discount Start Day
3. Press Button 4 – Mon-Sun/Everyday
4. Press Button 4 again – Everyday flashes
5. Advance on Button 2 to desired day
6. Press Button 4 – On/Off flashes
7. Advance on Button 2 to change current status
8. Press Button 4 to ‘save’ setting
9. Set balance of Selections in manner described above
10. Exit on Button 1 – Discount Start Day
11. Advance on Button 2 – Start hh:mm (hour/ minutes)
12. Press Button 4 – hh flashes
13. Advance on Button 2 to desired setting
14. Press Button 4 to ‘save’ setting :mm flashes
15. Advance on Button 2 to desired setting
16. Press Button 4 to ‘save’ setting
17. Press Button 1 to exit – Start Time

Stop Time:

1. Advance on Button 2 – Stop Time
2. Press Button 4 – Stop Day
3. Press Button 4 – Mon-Sun/everyday
4. Advance on Button 2 to desired day
5. Press Button 4 – On/Off flashes
6. Advance on Button 2 to change current status
7. Press Button 4 to ‘save’ setting
8. Set balance of Selections in manner described above
9. Exit on Button 1 – Stop Day
10. Advance on Button 2 – Stop hh:mm (hour/ minutes)
11. Press Button 4 – hh flashes
12. Advance on Button 2 to desired setting
13. Press Button 4 to ‘save’ setting :mm flashes



15. Advance on Button 2 to desired setting
16. Press Button 4 to 'save' setting
17. Press Button 1 to exit – Stop Time

Set Discount Amount:

The Discount is the amount being subtracted from the regular vend price.

1. Press Button 4 - .00 flashing
2. Advance on Button 2 to desired discount amount
3. Press Button 4 to 'save' setting
4. Press Button 1 to exit – Discount Amount

Override: (Optional Kit)

The Key Switch Override Kit allows the operator to 'bypass without removing' Timing Features the operator has programmed in the controller.

- On – Key Switch will override these Timing features.
- Off – Key Switch will not override these Timing features.

The following Timing features can be programmed to the key switch.

- Free Vend – On/Off
- Sales Blocking – On/Off
- Discount – On/Off
- Light Timing – On/Off
- Refrigeration – On/Off

Free Vend:

1. Enter on Button 4 – On/Off flashes
2. Advance on Button 2 to desired setting
3. Press Button 4 to 'save' setting
4. Press Button 1 to exit – Free Vend

Program Sales Blocking, Discount, Light Timing and Refrigeration in the manner described above. Press Button 1 to exit.

Custom Message:

The custom message feature allows the operator to program a 2 line X 20 character message.

*** Note:**

- 1. Press Button 1 to make a space between words.**
- 2. The message cannot be saved until all the characters on the top line have been entered.**

1. Press Button 4 at Custom Message – Enable On/Off
2. Press Button 2 – On/Off flashes
3. Advance on Button 2 to On



4. Press Button 4 to 'save' setting
5. Advance on Button 2 – current messages displays
6. Press Button 4 – 1st character flashes 7. Press Button 2 to advance to desired character
8. Press Button 4 to 'save' character – immediately advances to next character
9. Continue setting message using steps outlined above
10. Press and hold Button 1 for 3 seconds to save the message and exit mode

Return:

Exits the programming mode and returns the vendor to stand-by

WIRING DIAGRAM

DOOR AND POWER DISTRIBUTION WIRING DIAGRAM

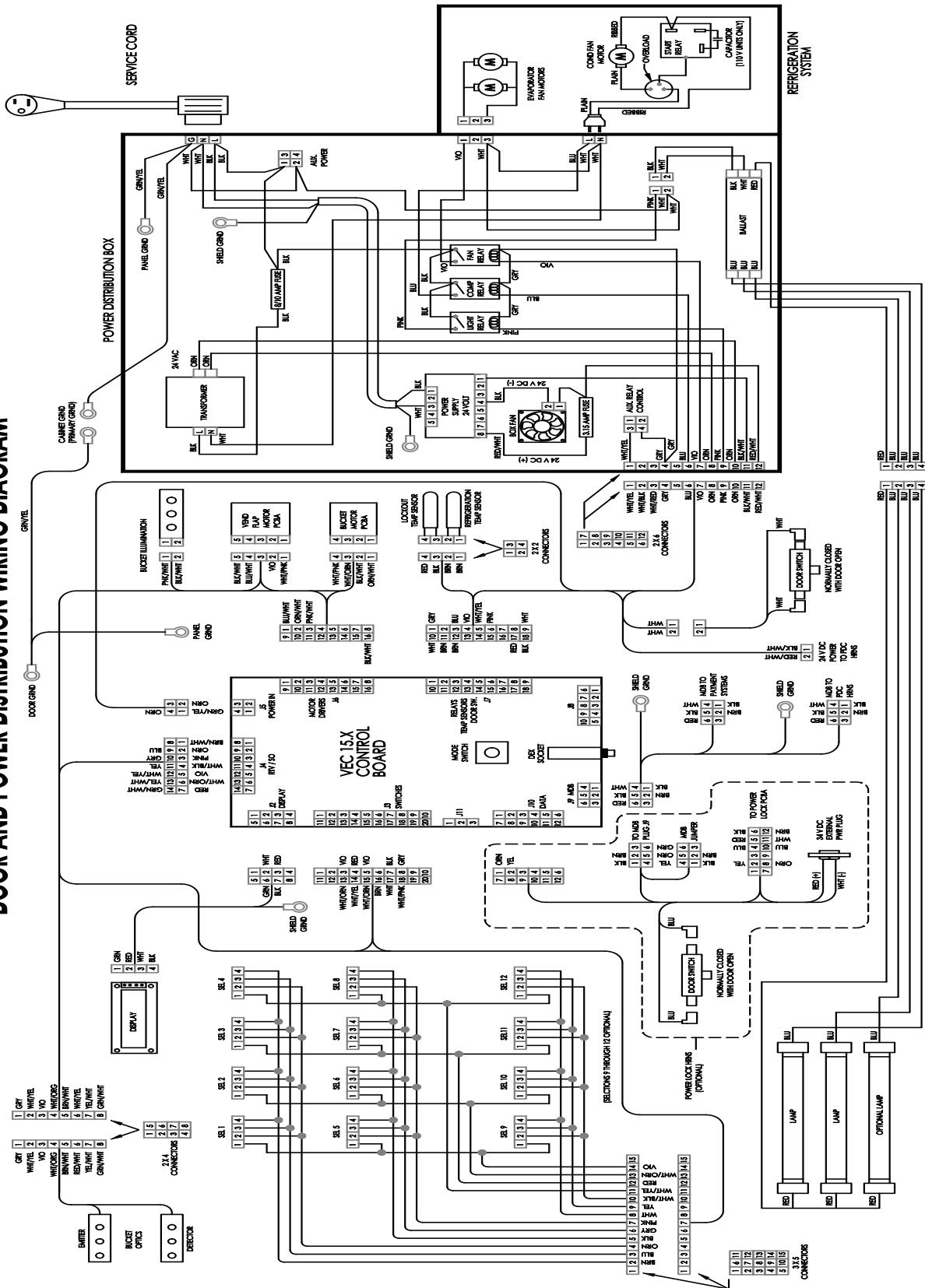

WIRING DIAGRAM (CONT.)

DELIVERY SYSTEM WIRING DIAGRAM

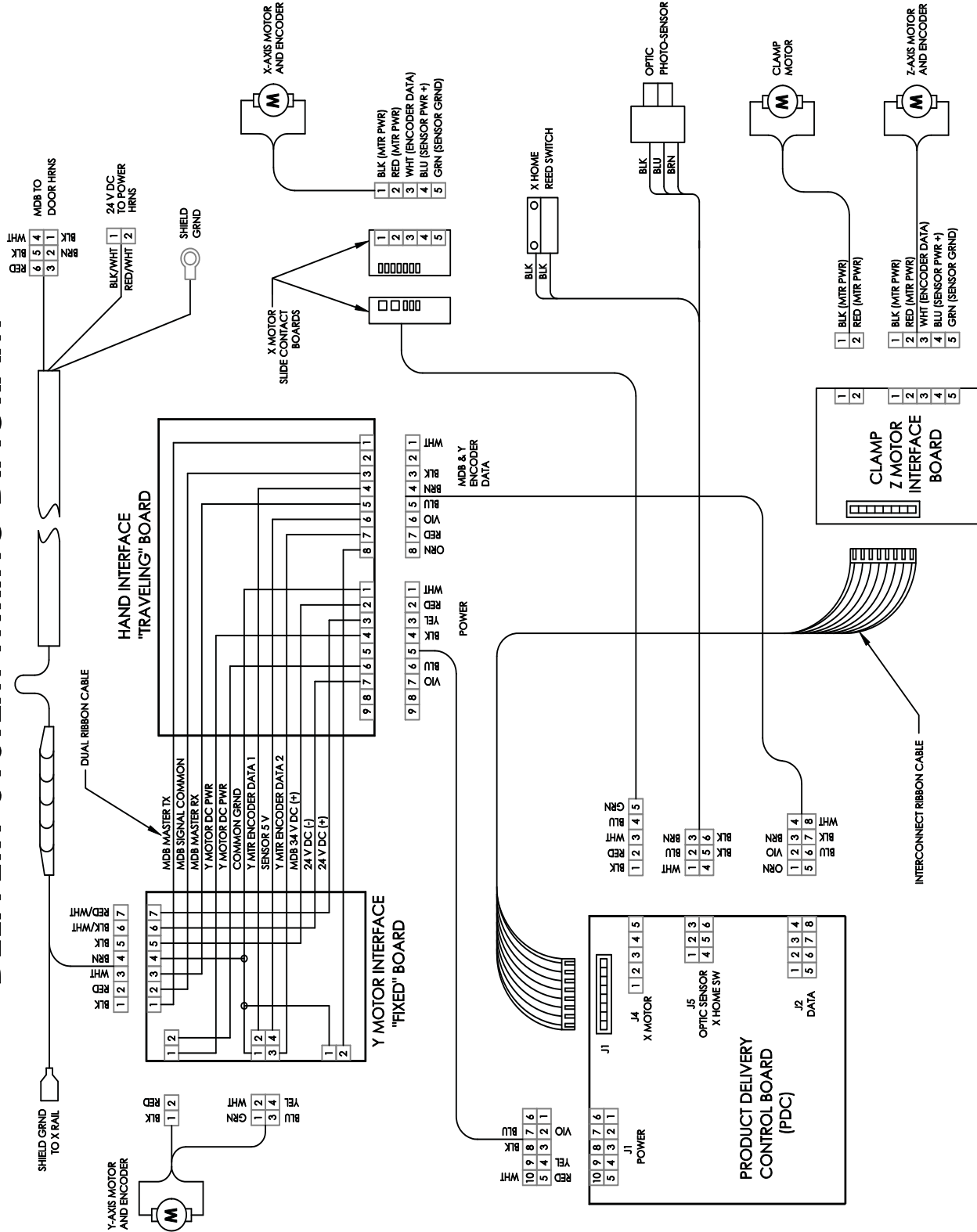

1156869

CUSTOM SPACE TO SALES DIAGRAM

Custom S-T-S Map



SAMPLE

Shelf 1	10
Selection #	1 & 9
Brand	COKE

Shelf 1	10	11	12	13	14	15	16	17
Selection #								
Brand								

Shelf 2	20	21	22	23	24	25	26	27
Selection #								
Brand								

Shelf 3	30	31	32	33	34	35	36	37
Selection #								
Brand								

Shelf 4	40	41	42	43	44	45	46	47
Selection #								
Brand								

Shelf 5	50	51	52	53	54	55	56	57
Selection #								
Brand								

Optional 6th and 7th shelves

Shelf 1	60	61	62	63	64	65	66	67
Selection #								
Brand								

Shelf 2	70	71	72	73	74	75	76	77
Selection #								
Brand								

Use the White area for SXY 30 and add the Gray for SXY 40

Date: _____ Service Tech: _____



VUE 30/40[®]

SXY

CABINET SECTION

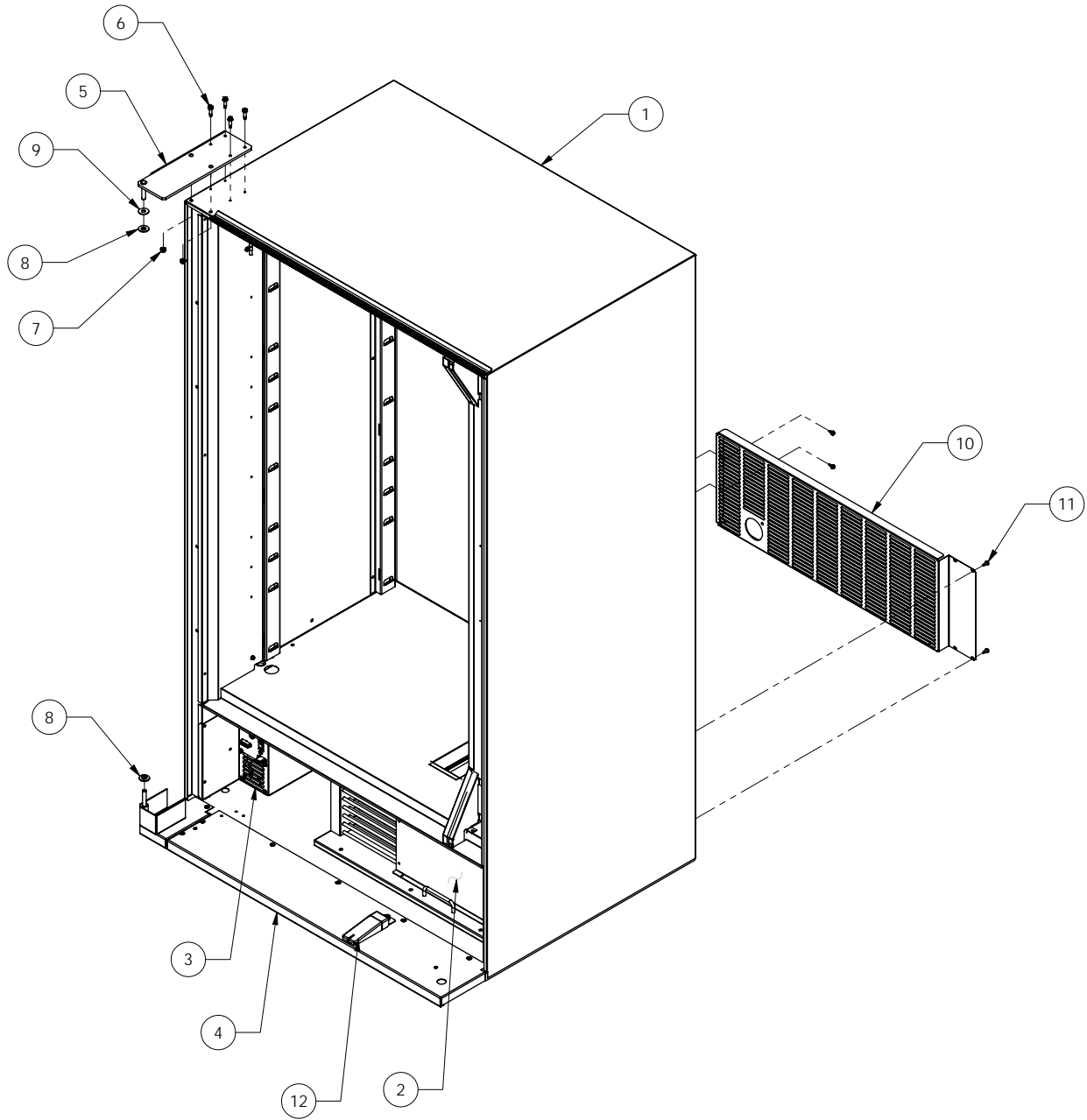



CABINET ASSEMBLY

ITEM NO	DESCRIPTION	QTY	PART NO
1	FOAMED CABINET	1	*
2	REFRIGERATION ASSEMBLY (SEE PAGE C-4)	1	~
3	POWER DISTRIBUTION ASSEMBLY (SEE PAGES C5)	1	~
4	ASY,CAB BASE COVER	1	1160333
5	ASY,UPPER HINGE	1	1160216
6	SCREW, ¼-14 1.0 HEX ZINC PLATE SELF TAP	4	V801490
7	NUT ¼-20 HEX STL MS & SEMS	2	V800959
8	BUSHING-HINGE	2	388094
9	FLAT WASHER	1	V801491
10	PNL,SCRN,REAR SXY30	1	1163849
	PNL,SCRN,REAR SXY40	1	1144364
11	SCR 10-16X1/2 P HX W HD ZP	4	V802141
12	RAMP ASSEMBLY	1	1133925
	RAMP, DOOR	1	1130868
	THUMB SCREW, 1/4-20 X .5, RAMP	1	1127060

FOR A COMPLETE LIST OF HARNESSSES, PLEASE SEE PAGE C-7.

* NOTE: WHEN ORDERING FOAMED CABINET ASSEMBLY OR BASE COVER PANEL, PLEASE PROVIDE 9- CODE AND MANUFACTURER'S DATE CODE.

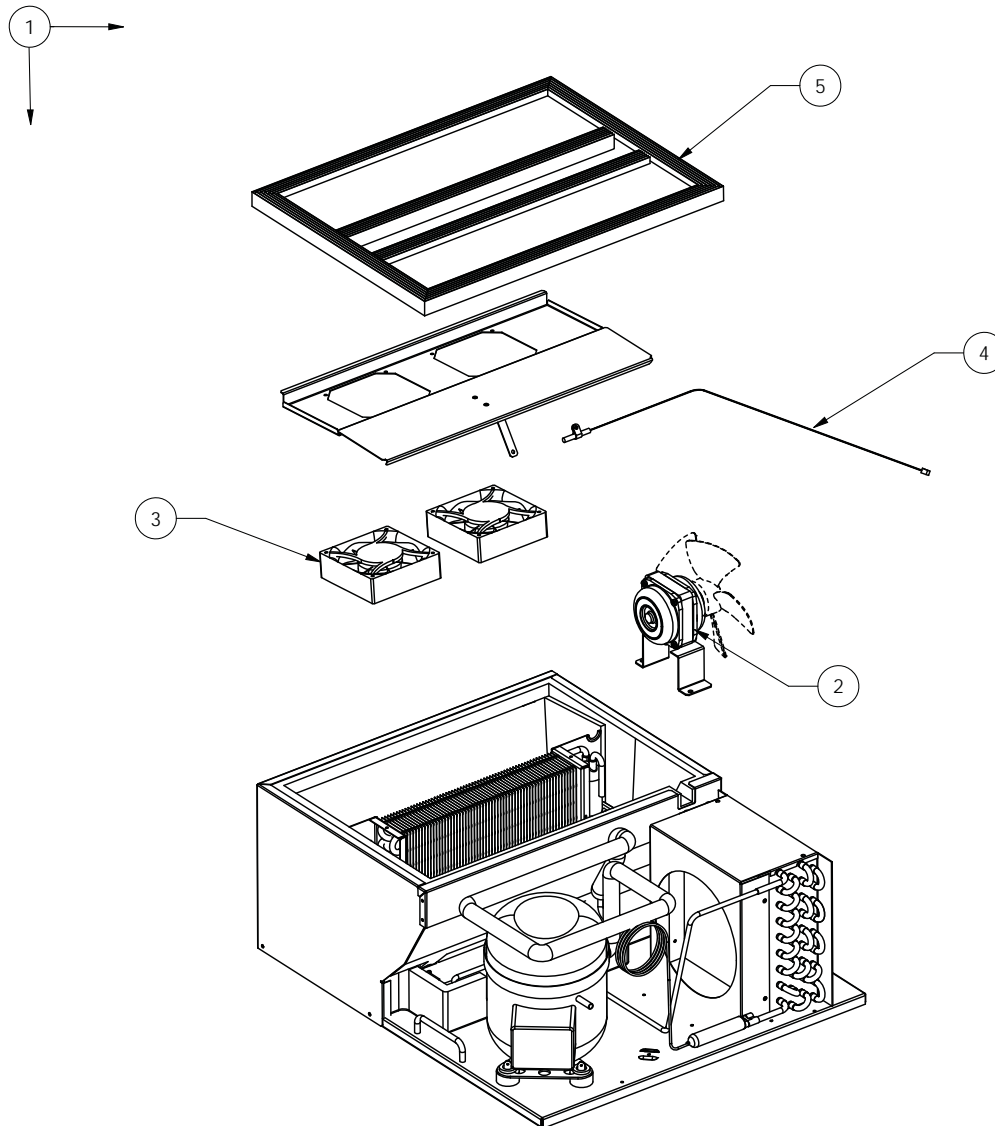

REFRIGERATION ASSEMBLY

ITEM NO	DESCRIPTION	QTY	PART NO
1	REFRIGERATION UNIT ASSEMBLY, 115V	1	1033131-267
	REFRIGERATION UNIT ASSEMBLY, 230V	1	1033131-268
2	FAN MOTOR, 115V	1	1127974
	FAN MOTOR, 230V	1	1127974-1
3	FAN ASSY, EVAPORATOR, 115V	1	1126260
	FAN ASSY, EVAPORATOR, 230V		1127994
4	TEMPERATURE SENSOR	1	1122924
5	GASKET, REFER	1	1127565

FOR A COMPLETE LIST OF HARNESES, PLEASE SEE PAGE C-7.

1

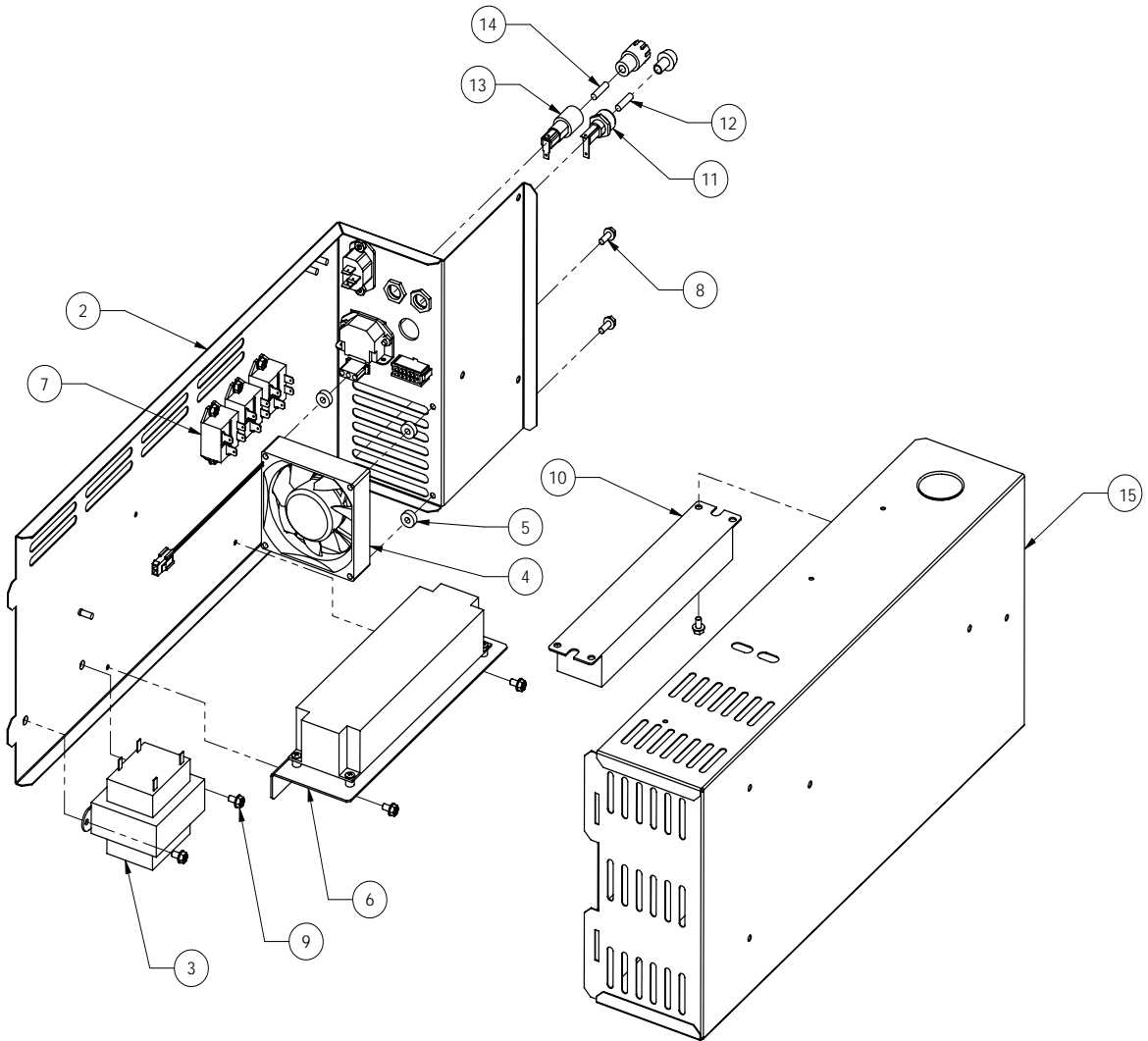



POWER DISTRIBUTION ASSEMBLY, 115V

ITEM	DESCRIPTION	QTY	PART NO.
1	PWR DIST ASY DOMESTIC 115V	1	1148125
	PWR DIST ASY DOMESTIC 230V		1148137
2	DISTRIBUTION PANEL	1	1148114
3	TRANSFORMER, 115V/24 VAC	1	1111201
	TRANSFORMER, 230V/24 VAC		1121932
4	PWR DISTRIBUTION FAN 24VOLT DC	1	1127890
5	BUSHING	4	1116634
6	POWER SUPPLY	1	1134012
7	RELAY, 24 VOLT DC	3	1128801
8	SCREW, #10-16 X 1/2 HEX HEAD	4	V801422
9	SCREW, #10-16 X 5/16 HEX HEAD	5	V801421
10	BALLAST ASY 115V	1	1162871
	BALLAST ASY 230V		1140965
11	HOLDER, FUSE 1-1/4 X 1/4	1	1128474
12	FUSE, 3.15 AMP SLOW BLOW	1	1127484
13	HOLDER, FUSE 5X20MM	1	1128473
14	FUSE, 0.8 AMP/250V, 3AG	1	1053864
15	BOX, DISTRIBUTION PANEL	1	1131242

FOR A COMPLETE LIST OF HARNESSSES, PLEASE SEE PAGE C-7.



HARNESS QUICK GUIDE

PART NO	DESCRIPTION
1165501	Cabinet Harness
1163345	Cabinet Harness Extension (Required for SXY40 Only)
1165548	Power Distribution Harness, High Voltage
1128750	Power Distribution Harness, Low Voltage
1148058	Fan Motor Harness
1145411	Compressor Power Cord
1150881	Cord Set 90 Deg Plug & IEC
1124938	Cord Set, UK
1124939	Cord Set, Cont. Europe
1124937	Cord Set, Australia



NOTES



SXY

SHELVES & TRAYS PARTS SECTION

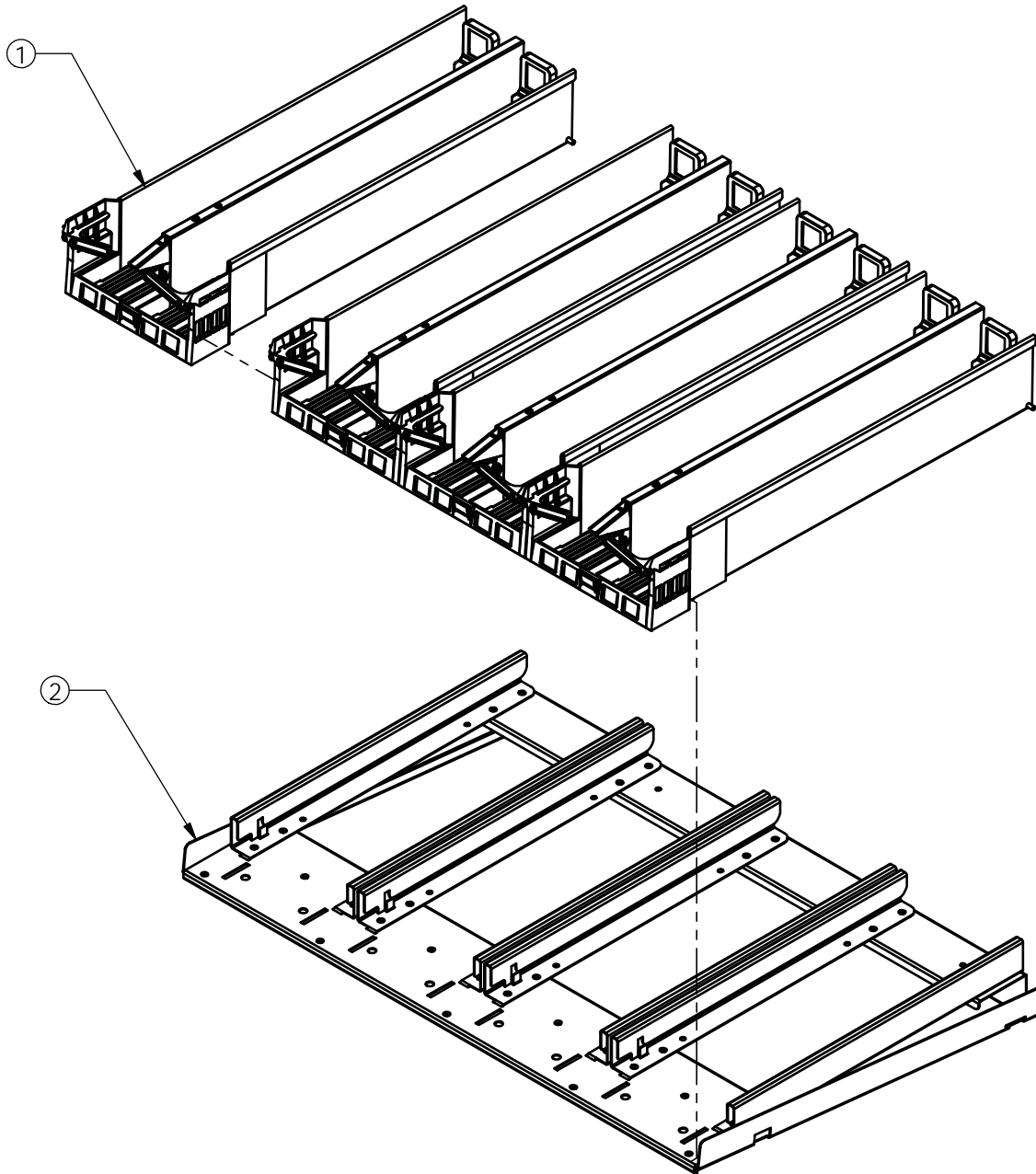

SHELF AND TRAY ASSEMBLY

ITEM NO	DESCRIPTION	QTY	PART NO
1	TRAY ASSEMBLY	1	1133755
2	SHELF ASSEMBLY, 41.5"	A/R	1125195
	SHELF ASSEMBLY, 34"	A/R	1136835

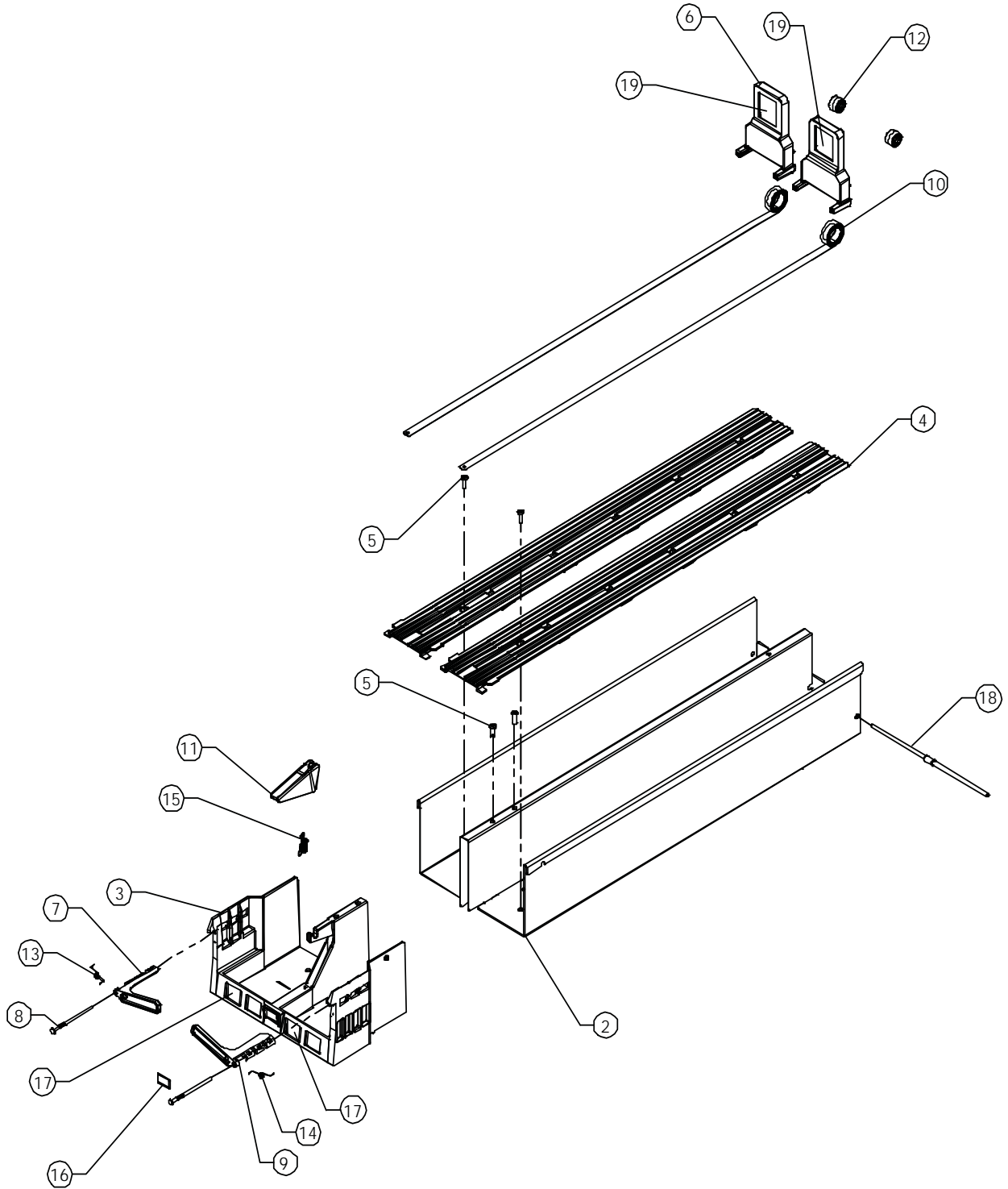



TRAY ASSEMBLY

ITEM	DESCRIPTION	QTY.	PART NO.
1	TRAY ASSEMBLY	1	1133755
2	TRAY BODY ASSEMBLY	1	1131291
3	TRAY FRONT	1	1133109
4	PRODUCT SLIDER, TRAY	2	1125141
5	SCREW #8-10 X 1/2" PAN HEAD	4	V802214
6	PUSHER, TRAY ASSY	2	1125140
7	GATE, LEFT, TRAY ASSY	1	1128285
8	PIN, PIVOT, TRAY FRONT	2	1125192
9	GATE, RIGHT, TRAY ASSY	1	1128284
10	SPRING, PUSHER, TRAY ASSY	2	1159665
11	GATE, CENTER, TRAY ASSY	1	1125737
12	ROLLER, SPRING	2	1125821
13	SPRING, TORSION, LEFT	1	1125856
14	SPRING, TORSION, RIGHT	1	1125856-1
15	SPRING, TENSION	1	1060023
16	REFLECTOR, TRAY ASSY	1	1126341
17	PRODUCT NUMBER LABEL	1	1139095
18	STOP ROD	1	1131897
19	SELECTION LABELS	1	1166633



NOTES



SXY

DOOR PARTS SECTION



READING A PARTS LIST

- I **ITEM NUMBER** is found in two locations:
 - A. It is on the drawing plate, and identifies the part and its location;
 - B. The same number is in the parts lists and ties the two together.

 - II **PART NUMBER** is the part number that has been assigned to a specific part by SandenVendo America, Inc., for easier identification.

 - III **QUANTITY REQUIRED** relates to the amount required of a part, or will be indicated by "A/R" (as required) to attach it to another part.

 - IV **PART NAME AND DESCRIPTION** is the general description for the part, for easier identification when ordering a like part.

 - V **HARDWARE** is identified by a letter in a hexagon. Refer to hardware list section or description and part numbers. See pages C-4 and C-5.
-

The example below will show how the parts are listed in the parts lists:

- 1. **VEND MOTOR ASSEMBLY:** This is the main assembly name, and any replaceable parts will be indented below the assembly.

- 2. **RETAINER CAM:** This is an individual part, and will be indented. These indented parts can be ordered separately, so you do not need to order the entire assembly.

- 3. Whenever an assembly is ordered, all the parts that are indented will be included in the assembly. Any hardware will be listed next to their corresponding parts.

- 4. Any parts that may be ordered separately will not have any indented parts listed below them.













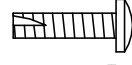

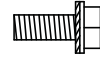

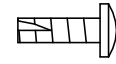

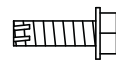



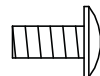



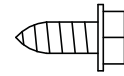

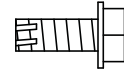

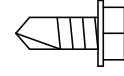

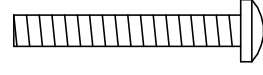

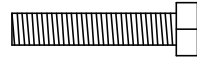

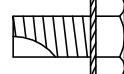

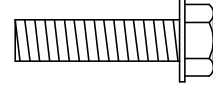
ITEM NO	DESCRIPTION	QTY REQ	PART NO.
1	VEND MOTOR ASSEMBLY	~	1115821
2	RETAINER CAM	1	1113244
3	TIMING CAM	1	1113236

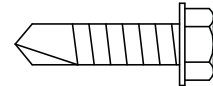

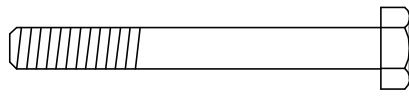

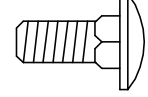

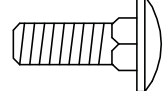





















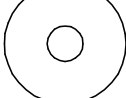

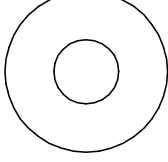
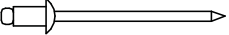
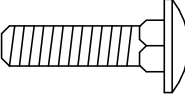

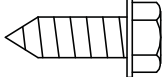
If an asterisk is listed below the parts list, it is an indication that special information is noted. There may be more than one asterisk (*) (**) (***) denoting special notes.

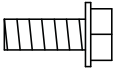

Purposely left blank

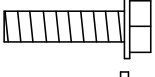
HARDWARE LIST

PART NO.	DESCRIPTION	PICTORIAL
A	V800762 #8 X 5/16" TAPPING SCREW	 
B	V802139 #8 X 5/8" TAPPING SCREW	 
C	V800586 #8 X 3/8" TAPPING SCREW W / LOCK WASHER	 
D	V802214 #8 X 1/2" TAPPING SCREW (FOR PLASTIC)	 
E	V801475 #8 X 1/2" TAPPING SCREW	 
F	V801421 #10 X 5/16" TAPPING SCREW	 
G	V802212 #10 X 3/8" TAPPING SCREW	 
H	V802047 #10 X 5/16" TAPPING SCREW W / LOCK WASHER	 
I	V802141 #10 X 1/2" TAPPING SCREW	 
J	V801422 #10 X 1/2" TAPPING SCREW	 
K	V801489 #10 X 1/2" SELF DRILLING SCREW	 
L	V800512 #10 X 1-3/8" TAPPING SCREW	 
M	V802115 #10 X 1" BOLT	 
N	V801360 1/4" X 1/2" TAPPING SCREW W / LOCK WASHER	 
O	V801343 1/4" X 1" TAPPING SCREW	 
P	V801490 1/4" X 1" SELF DRILLING SCREW	 
Q	V802053 1/4" X 2-1/4" BOLT	 
R	V802069 1/4" X 5/8" CARRIAGE BOLT	 
S	V801434 1/4" X 3/4" CARRIAGE BOLT	 

T	V800267	1/4" X 3/8" BOLT		
U	V800956	#8 NUT W / LOCK WASHER		
V	V800952	#10 NUT W / LOCK WASHER		
W	V802111	#10 HEX NUT		
X	V802113	#10 LOCK NUT W / NYLON INSERT		
Y	V800959	1/4" NUT W / LOCK WASHER		
Z	387925	1/4" LOCK NUT W / NYLON INSERT		
AA	V802062	3/8" LOCK NUT W / NYLON INSERT		
AB	V801013	#10 FLAT WASHER		
AC	389026	#10 FLAT WASHER, LARGER O.D.		
AD	V801491	3/8" FLAT WASHER		
AE	V801412	1/8" POP RIVET		
AF	V801435	1/4" 20 X 1" CARRIAGE BOLT		
AG	V802220	1/4" X 3/4" TAPPING SCREW		
AH	1123719	SPACER		
AI	V801422	#10 X 1/2" TAPPING SCREW		
AJ	V802133	#10-16 3/4HX CR SLFDRIL SCREW		
AK	V802301	WASHER,FLT,#12,NEOPRENE		

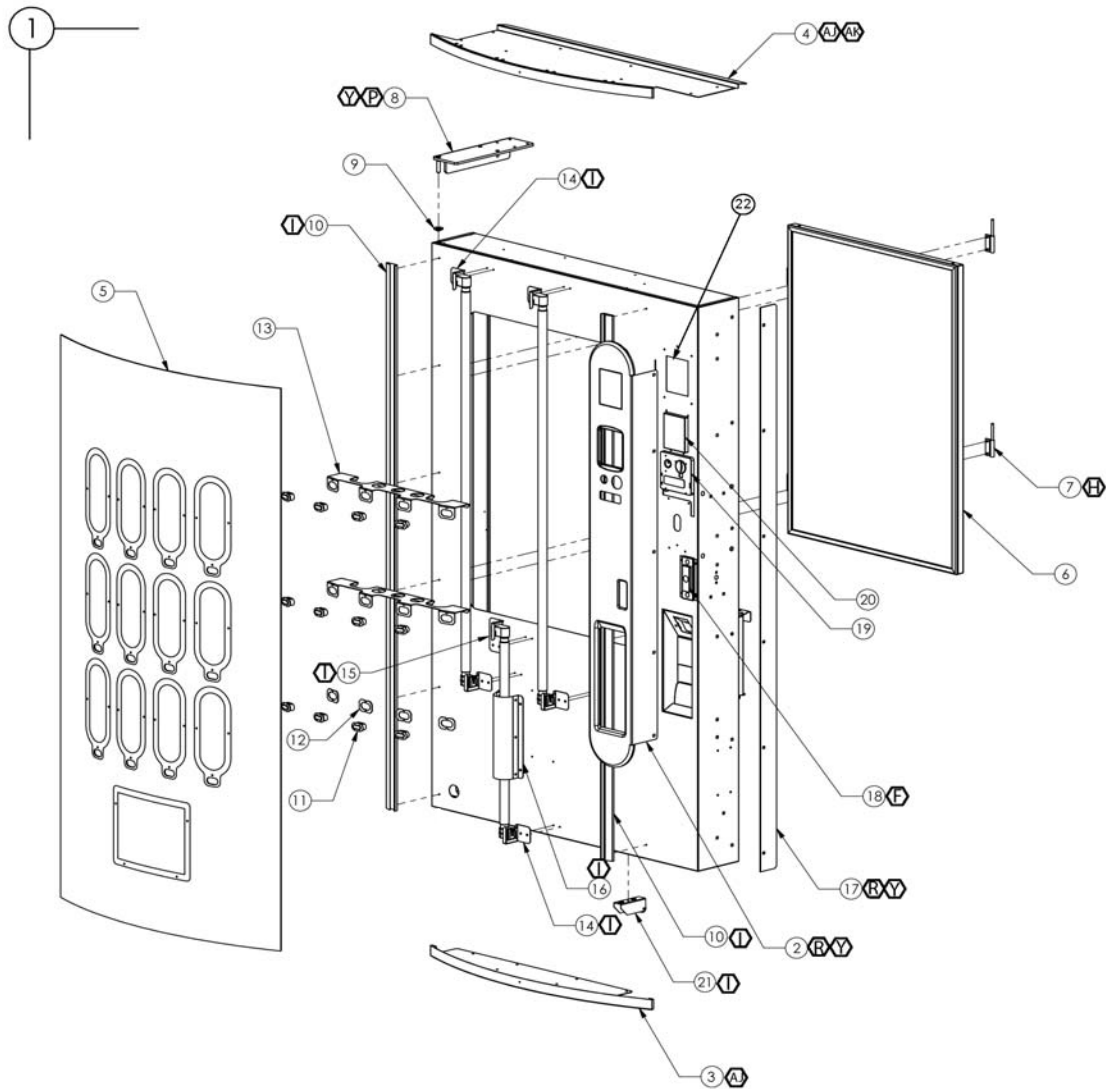



DOOR ASSEMBLY

ITEM NO	DESCRIPTION	QTY.	PART NO
1	SERVICE DOOR ASSEMBLY	~	*
2	CONTROL PANEL - 2 DBV KNOCKOUTS	1	1138338-7
	CONTROL PANEL - 1 DBV KNOCKOUT	1	1138338-6
	CONTROL PANEL - NO DBV KNOCKOUTS	1	1138338-8
3	CAP, SIGN FACE, BOTTOM	1	1159755
4	CAP, SIGN FACE, TOP	1	1159779
5	SIGN FACE	~	*
6	INNER DR,FOAM, 41.5"	1	134302-154
7	HINGE BENT,WITH PIN	2	1162172
8	ASY,UPPER HINGE	1	1160216
10	SIDE TRIM	2	1159767
11	BTN LIVE DISPLAY	12	1087074
12	BRACKET, BUTTON	8	1161283
13	BRACKET SUPPORT SIGN FACE	2	1167595
14	BKT,LAMP SOCKET	5	1160734
15	BKT,UPPER,LAMP SCK,2 FT	1	1161166
16	ASY,BULB GUARD	1	1161336
17	DOOR GUARD	1	*
18	T-HANDLE LOCK ASSEMBY (SEE D24)	1	1133778
19	COIN ENTRY & COIN RETURN ASSEMBLY (SEE D18-D19)	1	~
20	DBV PLUG	1	388216
21	DOOR ROLLER ASSEMBLY	1	1133482-7
22	DECAL PLUG PLATE	1	1166062

* NOTE: WHEN ORDERING SERVICE DOOR ASSEMBLY, CONTROL PANEL, OR DOOR GUARD, PLEASE PROVIDE **9-CODE** AND **MANUFACTURER'S DATE CODE**.

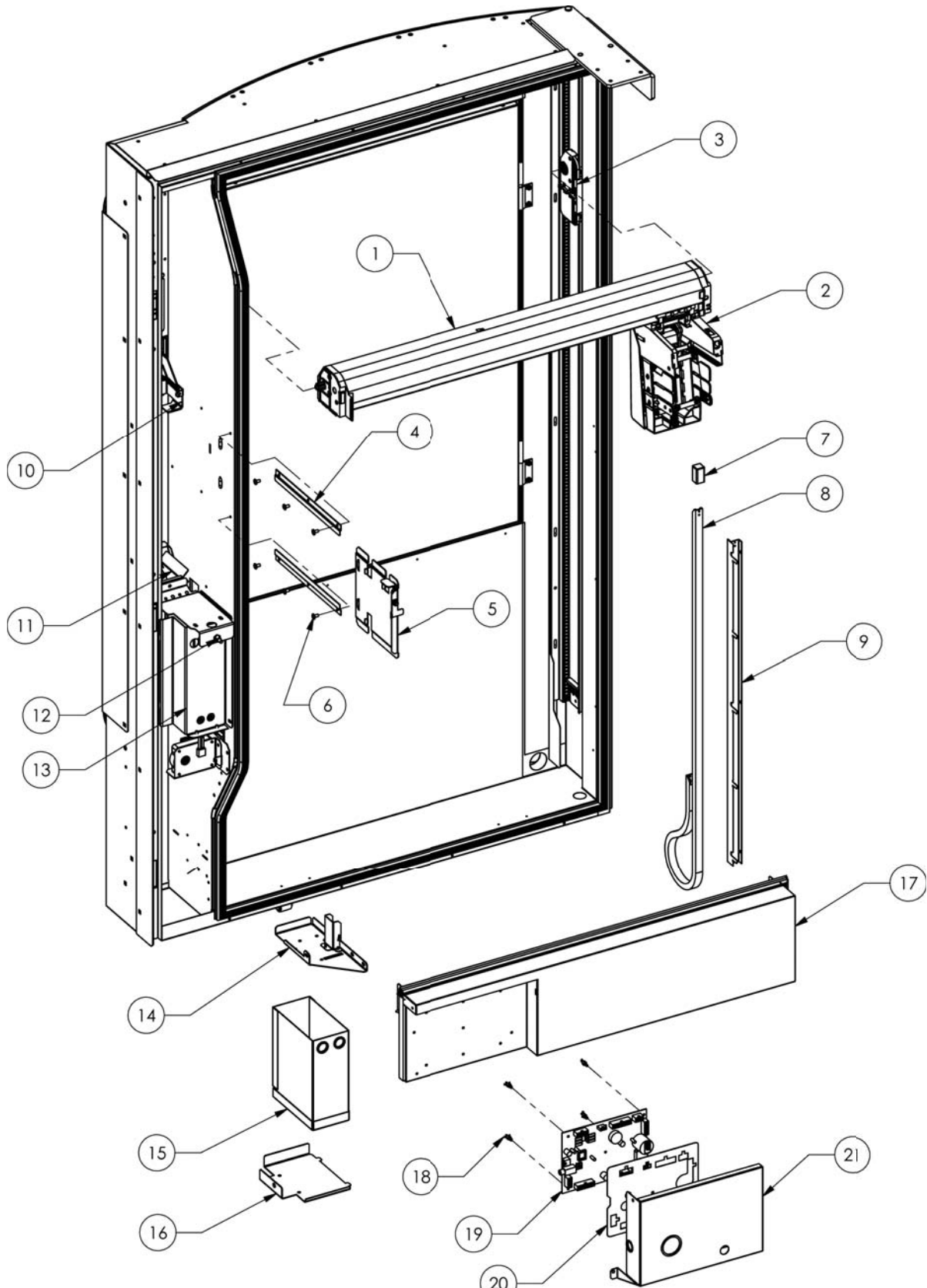



DOOR ASSEMBLY (CONTINUED)

ITEM NO	DESCRIPTION	QTY.	PART NO
1	X-RAIL & X-CARRIAGE ASY (SEE PGS D13-D16)	1	~
2	Z-HOUSING & HAND ASY (SEE PG D8)	1	~
3	Y-RAIL ASY - HINGE SIDE (SEE PGS D9-D10)	1	~
	Y-RAIL ASY - LATCH SIDE (SEE PGS D11-D12)	1	~
4	COINAGE GUIDE MOUNTING BRACKET	2	1130493
5	COINAGE MOUNTING BRACKET	1	1156615
6	SCREW, #10 X 3/8 CR TRUSS TAP	6	V802212
7	COVER, HARNESS LOOP	1	1138923
8	PDC HARNESS (LOWER MOUNTING VMC BD)	1	1156093
9	CABLE GUIDE BRACKET	1	1131356
10	COIN ENTRY & COIN RETURN ASY (SEE PGS D18-D19)	1	~
11	CHUTE, COINBOX	1	1130535
12	SWITCH DOOR DOUBLE POLE	1	1126607
13	DELIVERY ASSEMBLY (SEE PGS D20-D23)	1	~
14	MTG BRACKET ASY, COIN SECURITY OPTION	1	1134061
15	COIN BOX	1	1130789
16	COIN BOX SHELF	1	1154862
17	LOWER INSULATED PANEL ASY-WITH CUT OUT, 41.5"	1	1135661
	LOWER INSULATED PANEL ASY-WITH CUT OUT 34"	1	1136124
18	STANDOFF	7	1121740
19	PCBA - VEC 15.1	1	1155889
20	PCBA COVER	1	1123529
21	CONTROLLER BOARD, COVER	1	1156055

* NOTE: WHEN ORDERING FOAMED DOOR ASSEMBLY PLEASE PROVIDE **9-CODE** AND **MANUFACTURER'S DATE CODE**.

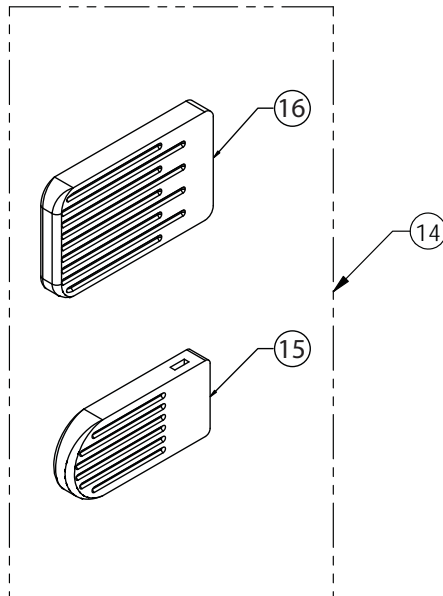
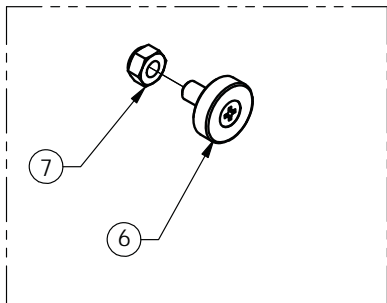
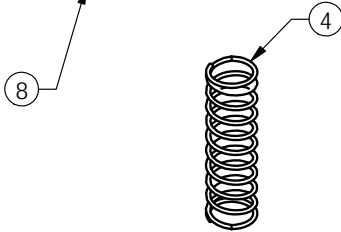
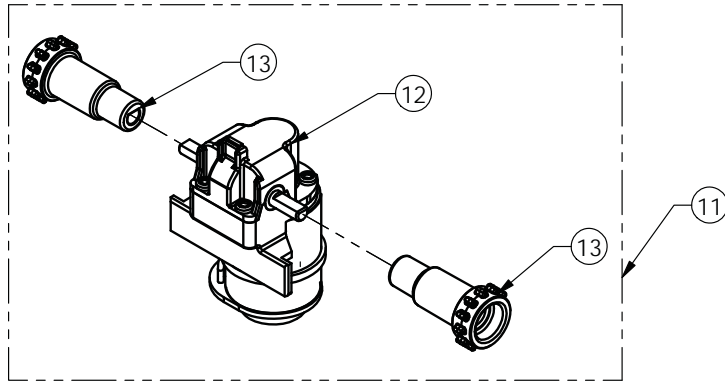
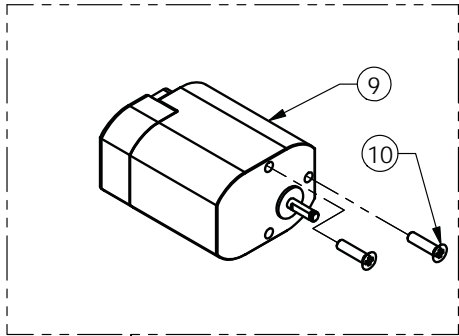
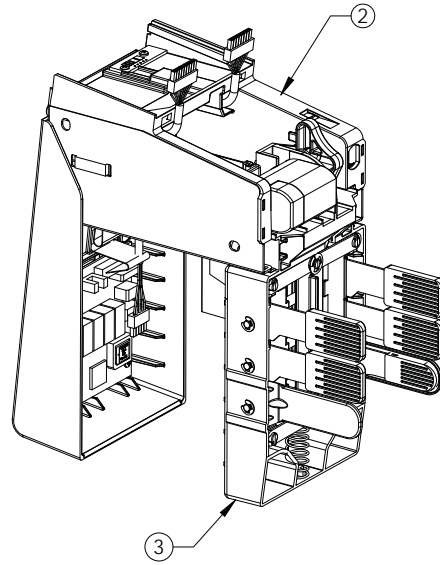
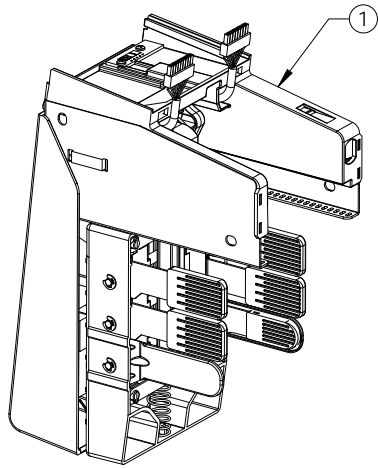



HAND ASSEMBLY

ITEM NO	DESCRIPTION	QTY	PART NO
1	Z HOUSING/HAND ASSEMBLY	1	1144296
2	Z HOUSING ASSEMBLY	1	1133857
3	HAND ASSEMBLY	1	1142366
4	SPRING, DRIVER ASSIST	1	1127303
5	ROLLER GUIDE REPLACEMENT KIT	1	1128060
6	ROLLER GUIDE	1	1125068
7	NYLOCK NUT - 6mm	1	V802235
8	CLAMP MOTOR REPLACEMENT KIT	1	1128061
9	MOTOR, CLAMP AXIS	1	1128800
10	SCREW - 3mm X 12mm - CR FLAT HEAD	2	V802254
11	Z MOTOR REPLACEMENT KIT	1	1128062
12	X-Z DRIVE MOTOR	1	1130602
13	DRIVE WHEEL - Z AXIS	2	1123967
14	FINGER PAD REPLACEMENT KIT	1	1142457
15	GRIPPER - FINGER - GFV	2	1129295
16	PAD - GRIPPER - UPPER/MID	4	1128713

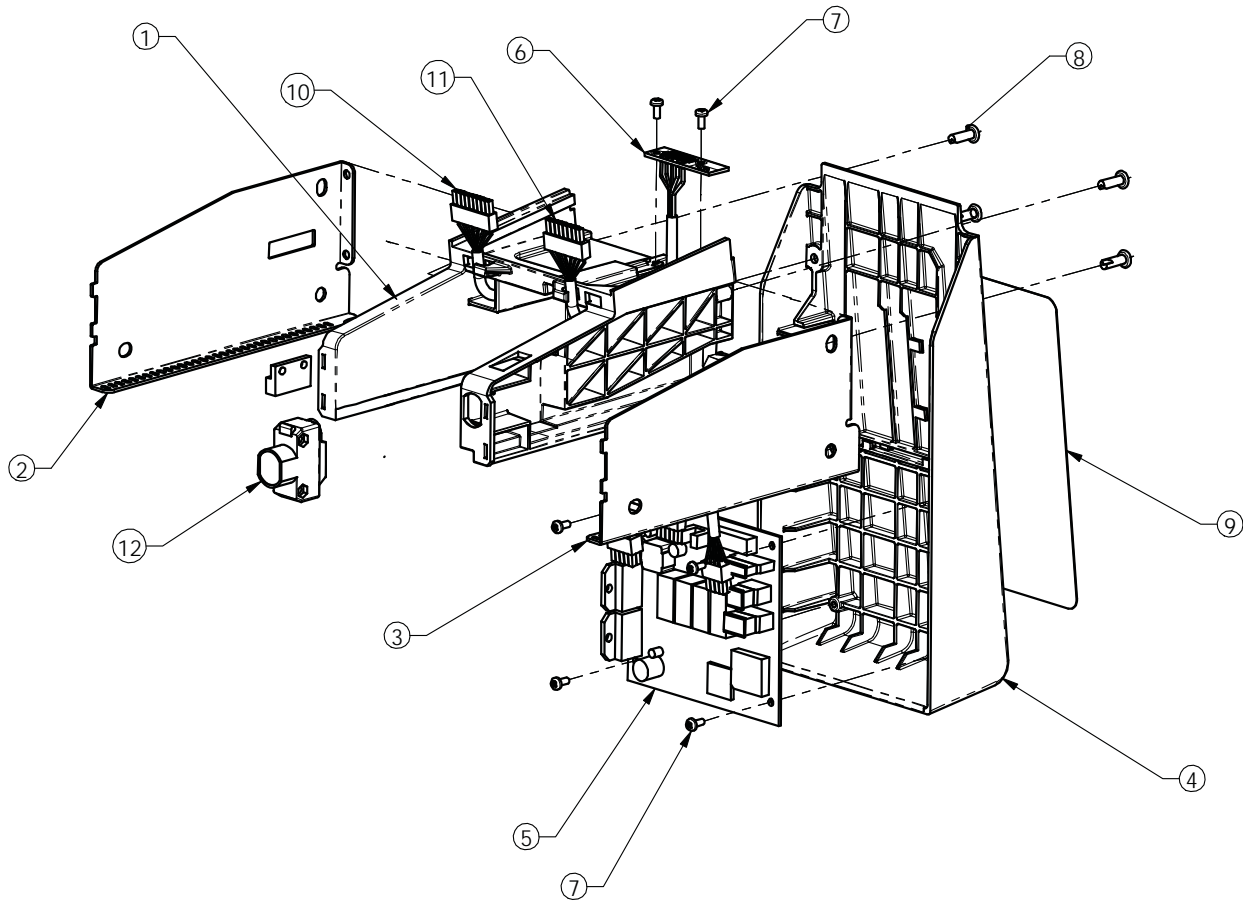

Z HOUSING ASSEMBLY

ITEM NO	DESCRIPTION	QTY	PART NO
1	HOUSING - Z AXIS	1	1128653
2	RAIL - RIGHT	1	1125081-1
3	RAIL - LEFT	1	1125081
4	COVER - BACK	1	1125055
5	PDC CONTROLLER BOARD	1	1133158
6	WIRE ASY, X-MOTOR MATING BOARD	1	1136264
7	TAPPING SCREW - #4 PLASTITE	6	V802186
8	SCREW, # 8 - 10 X 1/2" LG	4	V802214
9	DECAL - BACK COVER	1	*
10	HARNESS - HAND - POWER	1	1126309
11	HARNESS - HAND - DATA	1	1126310
12	SENSOR HARNESS ASSY	1	1126113

* NOTE: WHEN ORDERING THE DECAL - BACK COVER, PLEASE PROVIDE **9-CODE** AND **STYLE**.

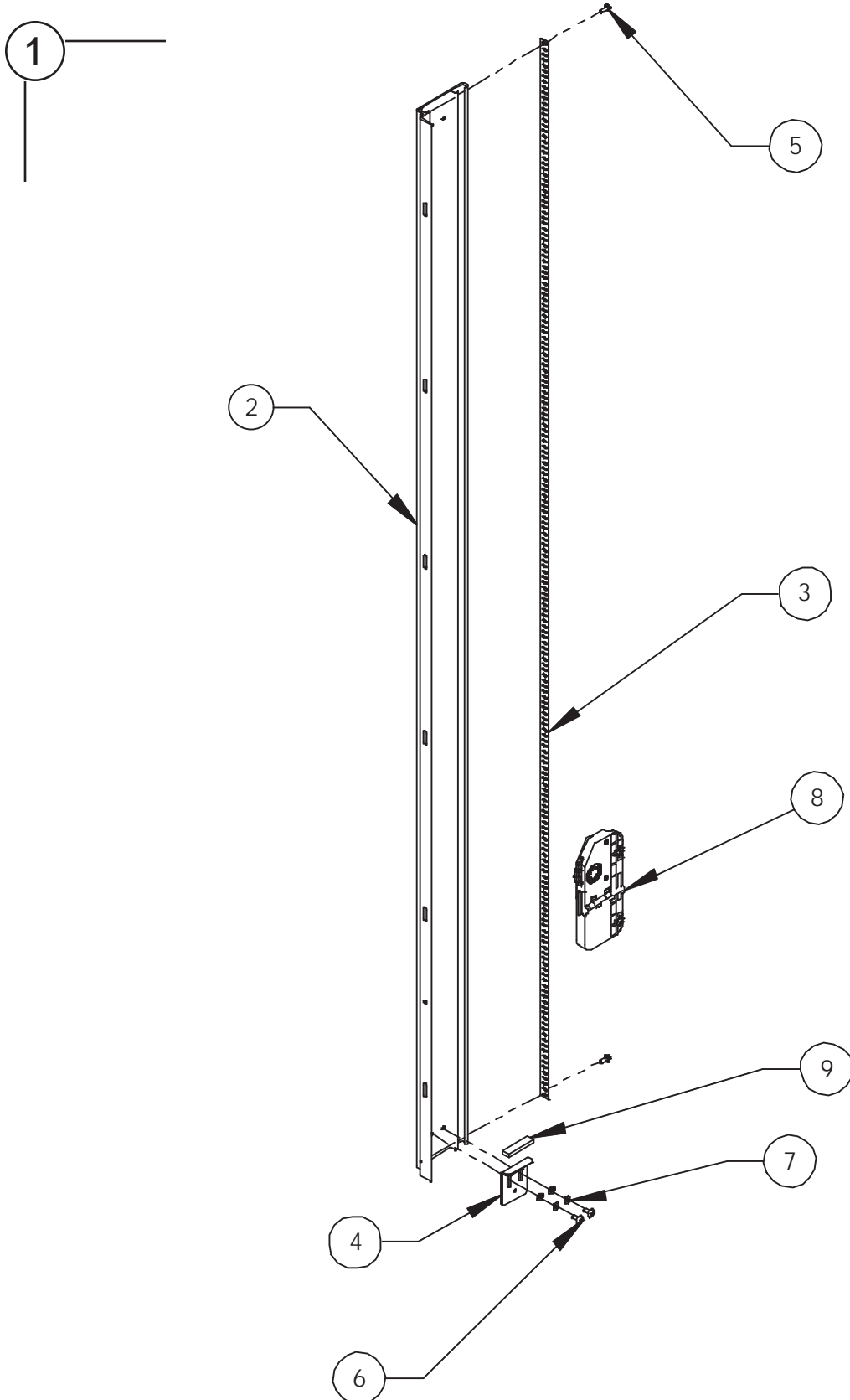



Y RAIL ASSEMBLY - LEFT / HINGE SIDE

ITEM NO	DESCRIPTION	QTY.	PART NO
1	Y-RAIL ASSEMBLY, HINGE SIDE	1	1133419
2	EXTRUSION RAIL - Y AXIS - LEFT	1	1128139
3	STRIP - DRIVE TRACK - Y AXIS	1	1128142
4	BRKT - STOP - Y RAIL	1	1131151
5	8-18 7/16 HEX SLOT STL-ZINC	2	V800586
6	SCREW, #10 - 16 X 3/8	2	V802212
7	WSHR .375 O.D. X .170 I.D.	4	V801455
8	DRIVE CARRAGE ASSY - Y AXIS - LEFT	1	1127863
9	PAD, Y-AXIS STOP, GFV	1	1127935

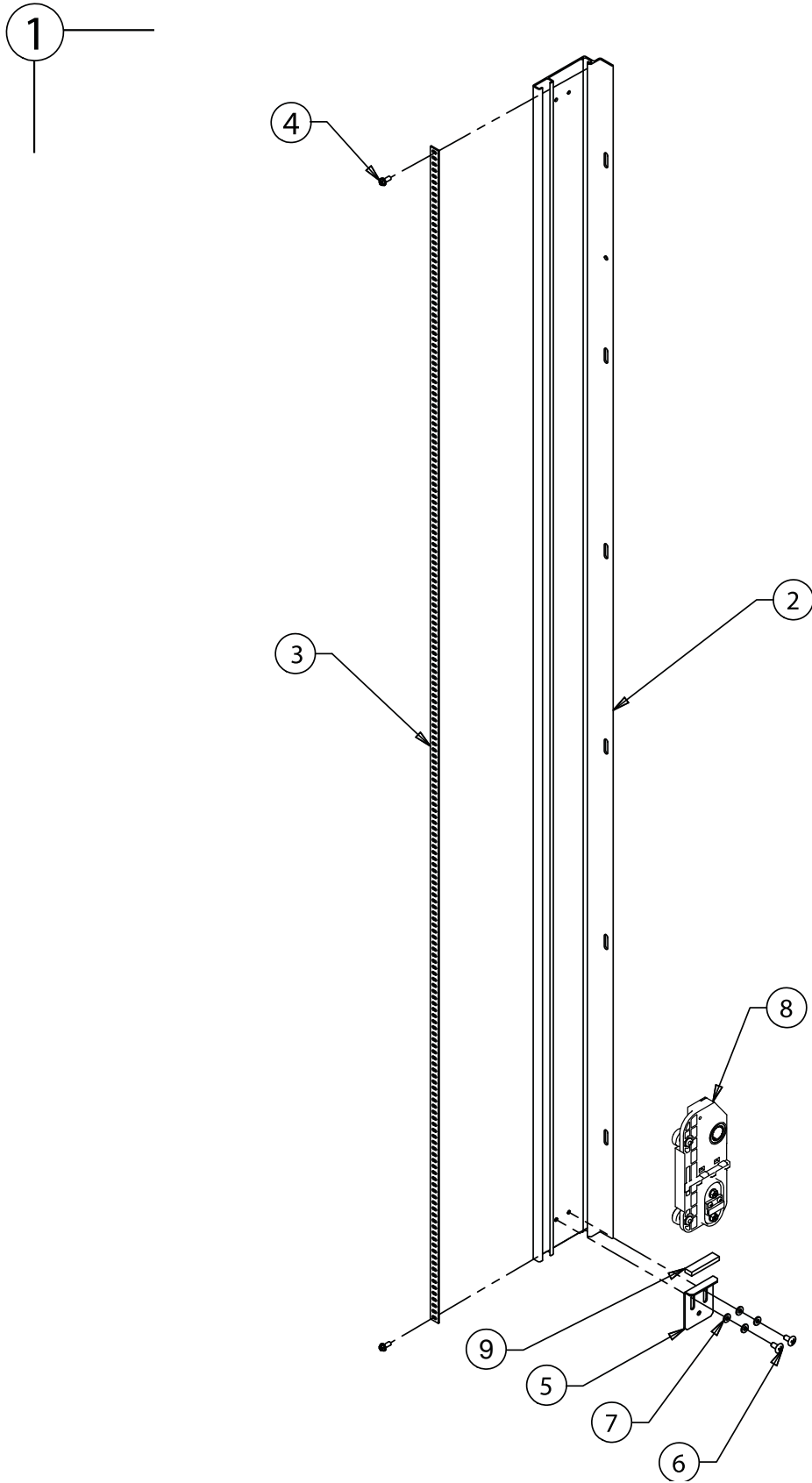



Y RAIL ASSEMBLY - RIGHT / LATCH SIDE

ITEM NO	DESCRIPTION	QTY	PART NO
1	Y RAIL ASSEMBLY, LATCH SIDE	1	1133421
2	EXTRUSION RAIL - Y AXIS - RIGHT	2	1128139
3	STRIP - DRIVE TRACK - Y AXIS	1	1128142
4	8-18 7/16 HEX SLOT STL-ZINC	2	V800586
5	BRKT - STOP - Y RAIL	1	1131151
6	SCREW, #10 - 16 X 3/8	2	V802212
7	WSHR .375 O.D. X .170 I.D.	4	V801455
8	DRIVE CARRAGE ASSY - Y AXIS - RIGHT	1	1127862
9	PAD, Y-AXIS STOP, GFV	1	1127935

1

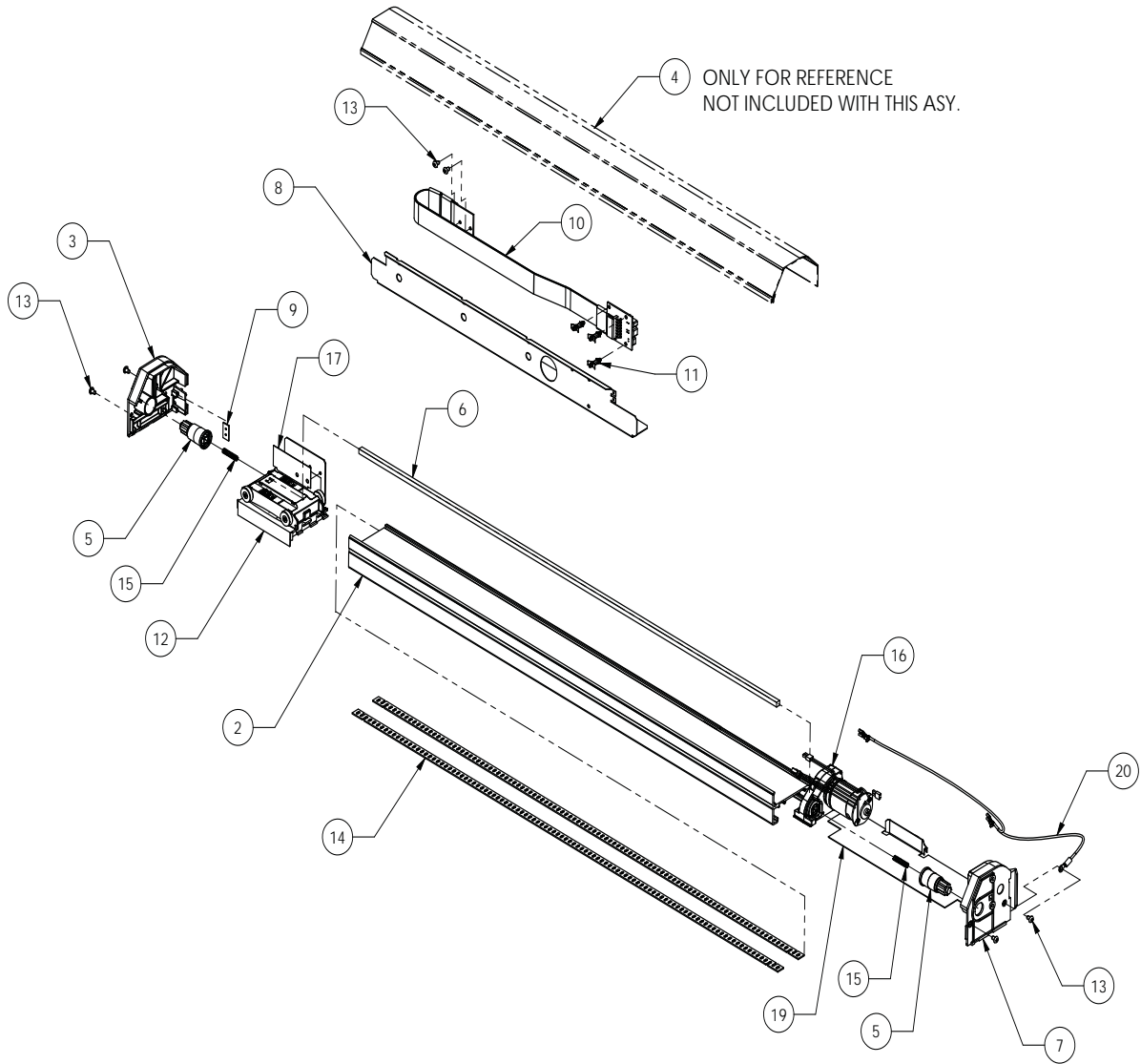



X RAIL ASSEMBLY

ITEM NO	DESCRIPTION	QTY	PART NO
1	RAIL ASSEMBLY - X AXIS - 41.5"	1	1133559
	RAIL ASSEMBLY - X AXIS - 34"	1	1136718
2	EXTRUSION RAIL - X AXIS - 41.5"	1	1127460
	EXTRUSION RAIL - X AXIS - 34"	1	1127460-1
3	END CAP, X-RAIL, LH	1	1127536
4*	COVER, TOP, X-AXIS DRIVE, 41.5"	1	1127534
	COVER, TOP, X-AXIS DRIVE, 34"	1	1127534-1
5	COUPLING, DRIVE	2	1127331
6	SQUARE SHAFT, .25, Y-AXIS, 41.5"	1	1125078
	SQUARE SHAFT, .25, Y-AXIS, 34"	1	1125078-1
7	END CAP, X-RAIL, RH	1	1127535
8	PARTITION, RIBBON CABLE	1	1165305
9	PLATE, TAPPING, END CAP	1	1130833
10	RIBBON CABLE ASSY - X RAIL	1	1127463
11	STANDOFF, PCBA, Y-MOTOR	3	1126194
12	CARRIAGE ASSY, X-AXIS, GFV (SEE D15-D16)	1	1133561
13	SCREW, #8-18 X 1/4	6	V800634
14	STRIP - DRIVE TRACK - X AXIS - 41.5"	2	1128446
	STRIP - DRIVE TRACK - X AXIS - 34"	2	1128446-1
15	SPRING, Y-AXIS DRIVE ROD, GFV	2	1126156
16	DRIVE MOTOR, Y-AXIS	1	1165858
17	SHEET, INSULATOR, GFV TRAV BD	1	1126763
19	RTNR, Y-RAIL, X-RAIL ASY, GFV, 41.5"	1	1165317
	RTNR, Y-RAIL, X-RAIL ASY, GFV, 34"	1	1135317-1
20	GROUND HARNESS	1	1165525

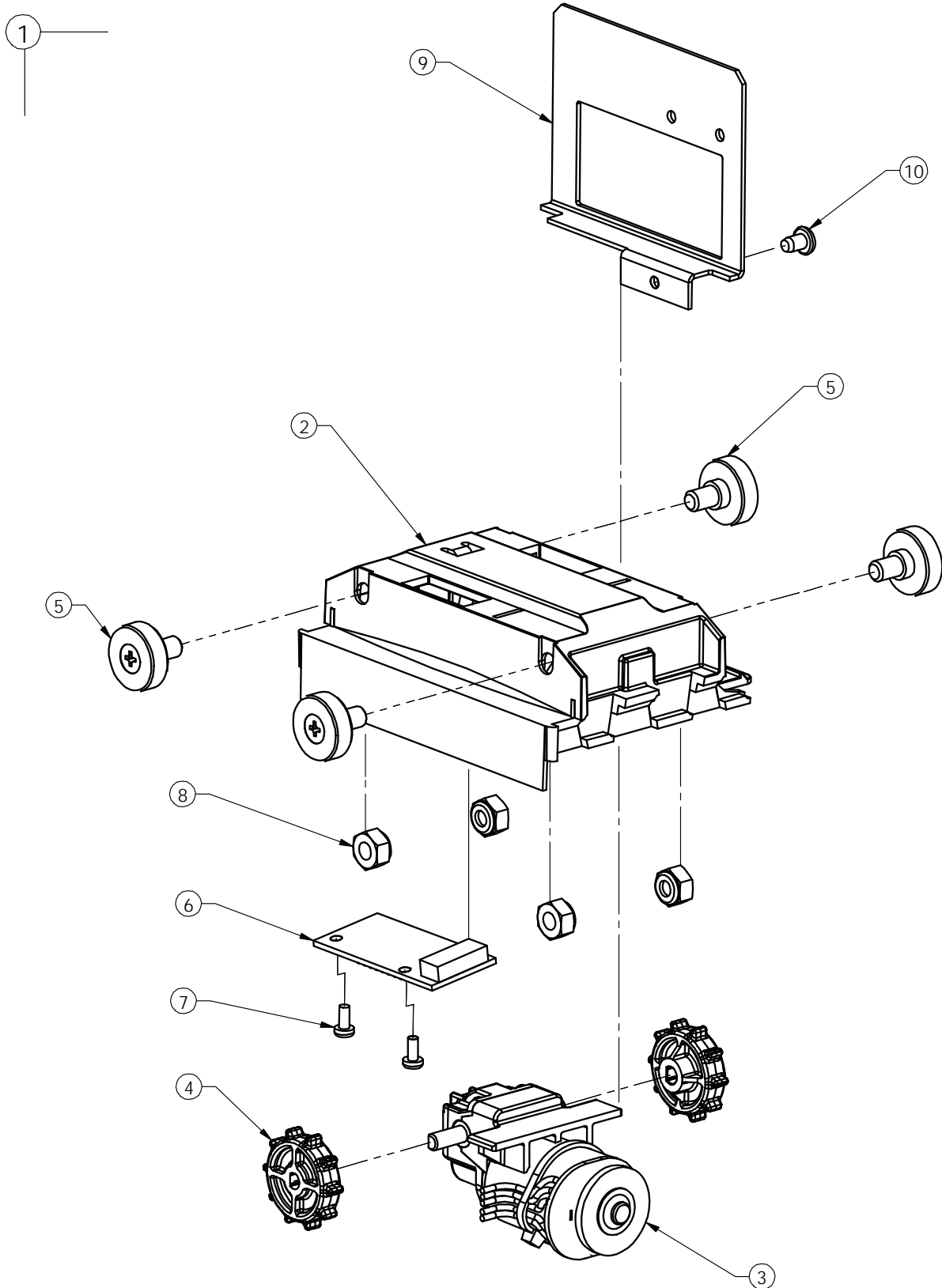



X AXIS CARRIAGE ASSEMBLY

ITEM NO	DESCRIPTION	QTY	PART NO
1	CARRIAGE ASSEMBLY - Y AXIS DRIVE	1	1133561
2	HOUSING - X CARRIAGE	1	1136215
3	X-Z DRIVE MOTOR	1	1130602
4	DRIVE WHEEL - X AXIS	2	1123961
5	ROLLER GUIDE	4	1125068
6	PC BOARD - CONNECTOR - X CARRIAGE	1	1130675
7	TAPPING SCREW - #4 PLASTITE	2	V802186
8	NYLOCK NUT - 6mm	4	V802235
9	BRKT - FFC CABLE ASSY	1	1130365
10	SCREW, # 8 - 18 X 1/4	1	V800634

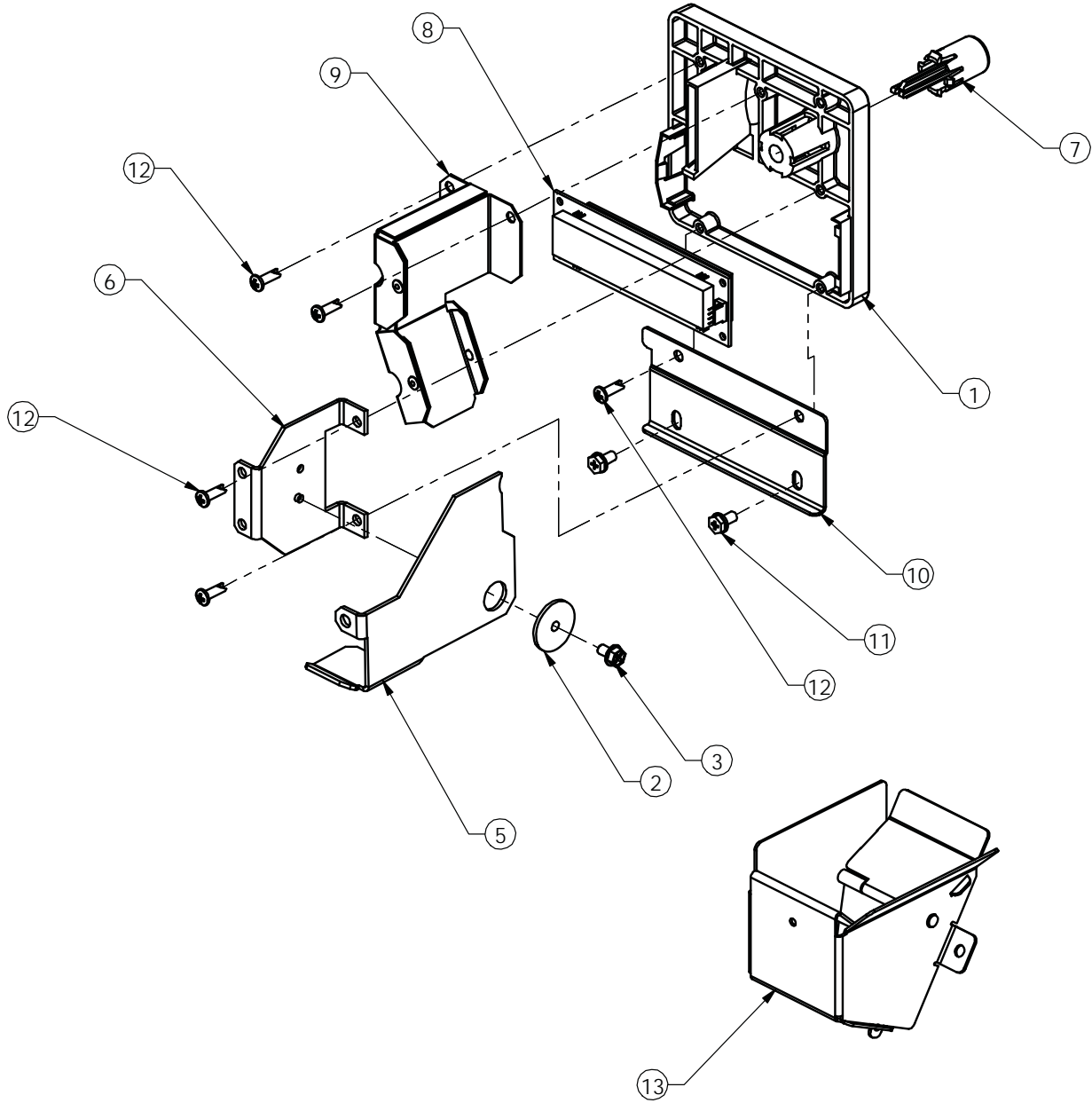



COIN ENTRY & COIN RETURN ASSEMBLY

ITEM NO	DESCRIPTION	QTY	PART NO
1	COIN INSERT, GFV	1	1125367
	LEVER,SCAVENGER ASSY, GFV	1	1133652
2	SHOULDER WASHER,NYLON	1	1122715
3	SCRW 10-16 5/16 B CR HEX TAP	1	V801422
4	(K) SPRING SOLD OUT	1	390326
5	LEVER,COIN RETURN,GFV	1	1131072
6	PIVOT BRKT,COIN RETURN LEVER	1	1151241
7	BUTTON, COIN RETURN	1	1050473
8	DISPLAY, 2X20 SERIAL (LED)	1	1121184
9	COIN CHUTE ASSY, GFV	1	1133638
10	BRKT, COIN INSERT SUPPORT	1	1130509
11	SCREW, #10 -16 X 3/8 B CR HEX STL	2	V801421
12	SCREW, # 8 - 10 X 1/2" LG	5	V802214
13	COIN RETURN CHUTE ASSEMBLY	1	1133936

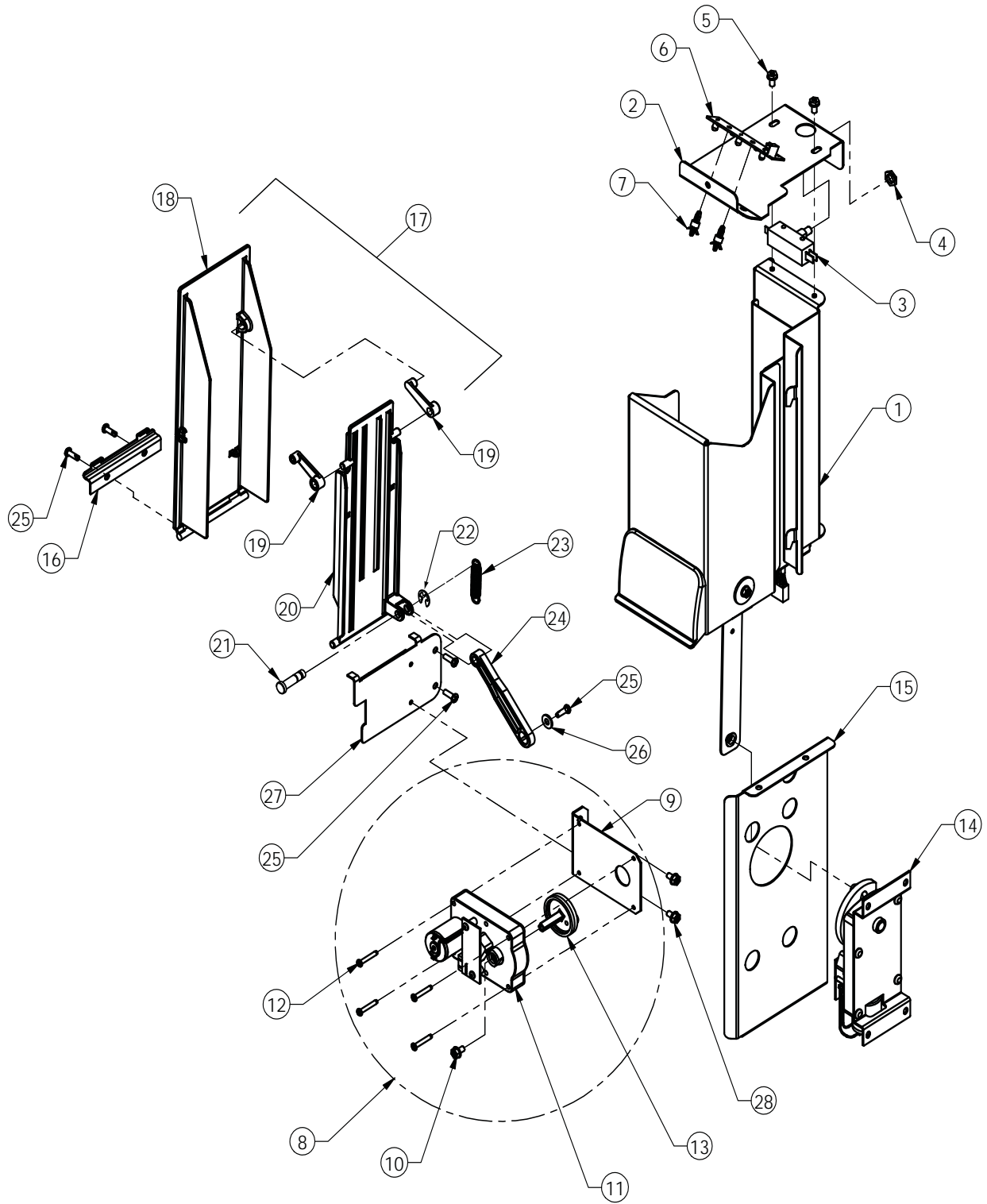



DELIVERY HOPPER AND FLAP ASSEMBLY

ITEM NO	DESCRIPTION	QTY	PART NO
1	DELIVERY BUCKET ASSEMBLY (SEE D23)	1	1164144
2	COVER PLATE, DELIVERY BUCKET	1	1163746
3	ELECTRIC DOOR SWITCH	1	323007
4	NUT, 3/8-32 X 3/32 HEX	1	V801449
5	SCREW, #10 -16 X 3/8 B CR HEX STL	2	V802047
6	PCBA, HOPPER ILLUMINATION LEDS	1	1130698
7	1/4 NYLON STANDOFF	2	1121740
8	ASSEMBLY, DELIVERY FLAP MOTOR	1	1133407
9	BRKT, DELIVERY FLAP MOTOR MTG	1	1131307
10	SCREW, #10-16 X 5/16 B CR HEX TAP	1	V801421
11	GEAR MOTOR, DELIVERY FLAP	1	1128802
12	SCREW, #8 X 7/8 CR PAN HD	4	V802180
13	CRANK, DELIVERY FLAP MOTOR	1	1128233
14	DELIVERY BUCKET MOTOR	1	1130614
15	BARRIER PANEL, BUCKET MOTOR	1	1131368
16	RETAINER, OUTER FLAP	1	1130455
17	FLAP ASSEMBLY, PRODUCT DELIVERY	1	1128272
18	FLAP, PRODUCT DELIVERY	1	1125871
19	LEVER ARM, DELIVERY FLAP	2	1125873
20	INNER FLAP, PRODUCT DELIVERY	1	1128236
21	PIVOT PIN, INNER FLAP, GFV	1	1128410
22	1/4 E SPG-STL RETAINER RINGS	1	V801077
23	SPRING	1	1126510
24	DRIVE LINK, DELIVERY FLAP	1	1128234
25	SCREW, #8-10X1/2 CR PN THRD CUT 25 ZI	5	V802214
26	WASHER #10 STL PLAIN	1	V801013
27	BRACKET, INNER FLAP RETAINER	1	1131319
28	SCREW, #10-16 X 5/16 B CR HEX TAP	2	V801421

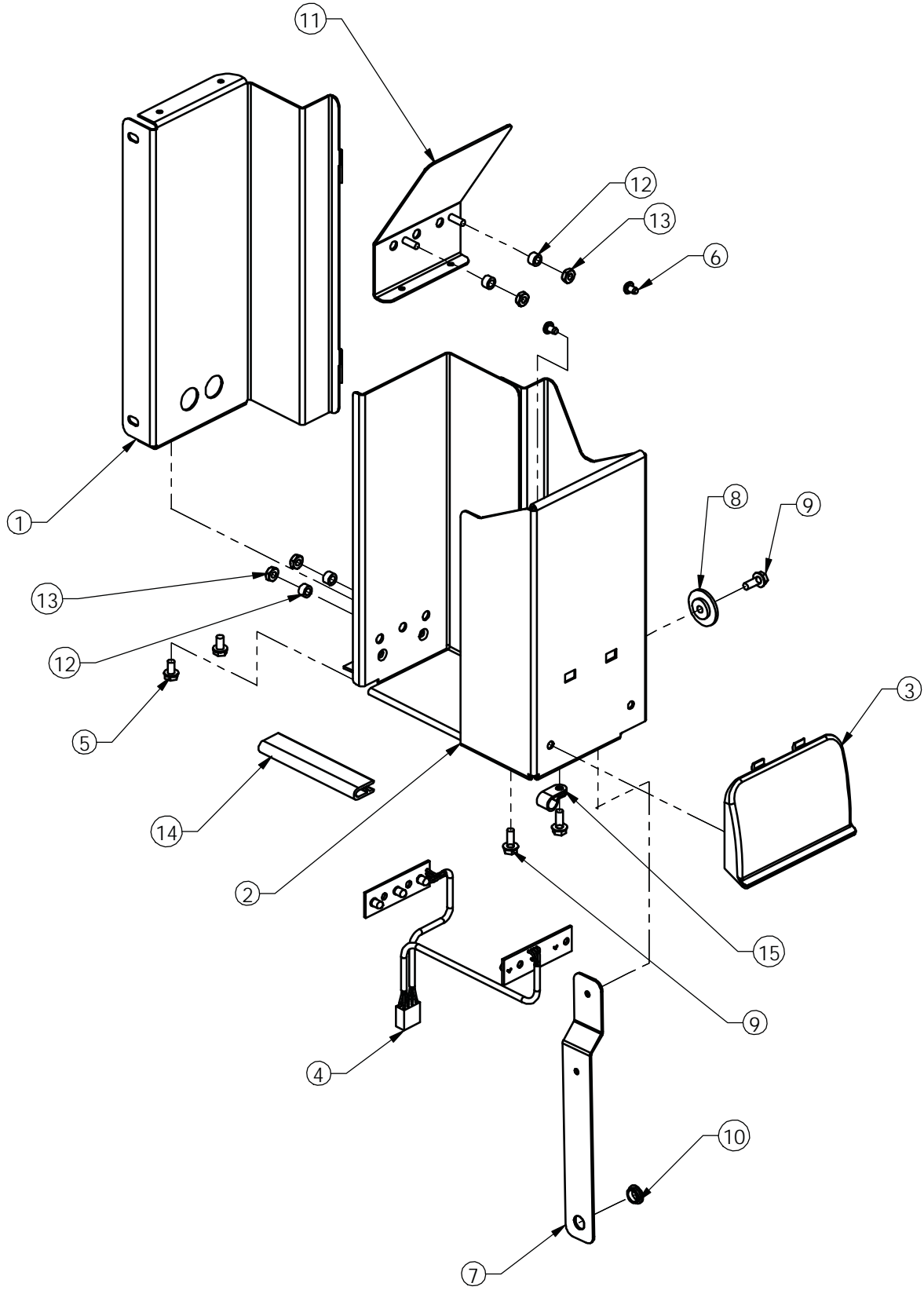



DELIVERY HOPPER ASSEMBLY

ITEM NO	DESCRIPTION	QTY	PART NO
1	BRACKET, DELIVERY BUCKET MOUNTING	1	1162342
2	BUCKET, DELIVERY	1	1164155
3	FOOTER, DELIVERY BUCKET	1	1128191
4	OPTIC DETECTOR ASSY	1	1130728
5	SCREW, #10-16 X 3/8 B CR HEX STL	2	V802047
6	SCREW, # 8-18 X 1/4	2	V800634
7	LINK, DELIVERY BUCKET DRIVE	1	1131473
8	WASHER, SHOULDER, NYLON	1	1122715
9	SCREW, #10 X 1/2	3	V801422
10	BEARING, NYLINER	1	385603-5
11	PLATE, DELIVERY BUCKET FILLER	1	1164805
12	SPACER, NYLON, #10 SCREW, 3/16"	4	1125765-1
13	NUT, #8 - 32 WITH LOCK WASHER	4	V800956
14	EDGE TRIM BUMPER	1	1127310
15	CLAMP .25	1	324099-3

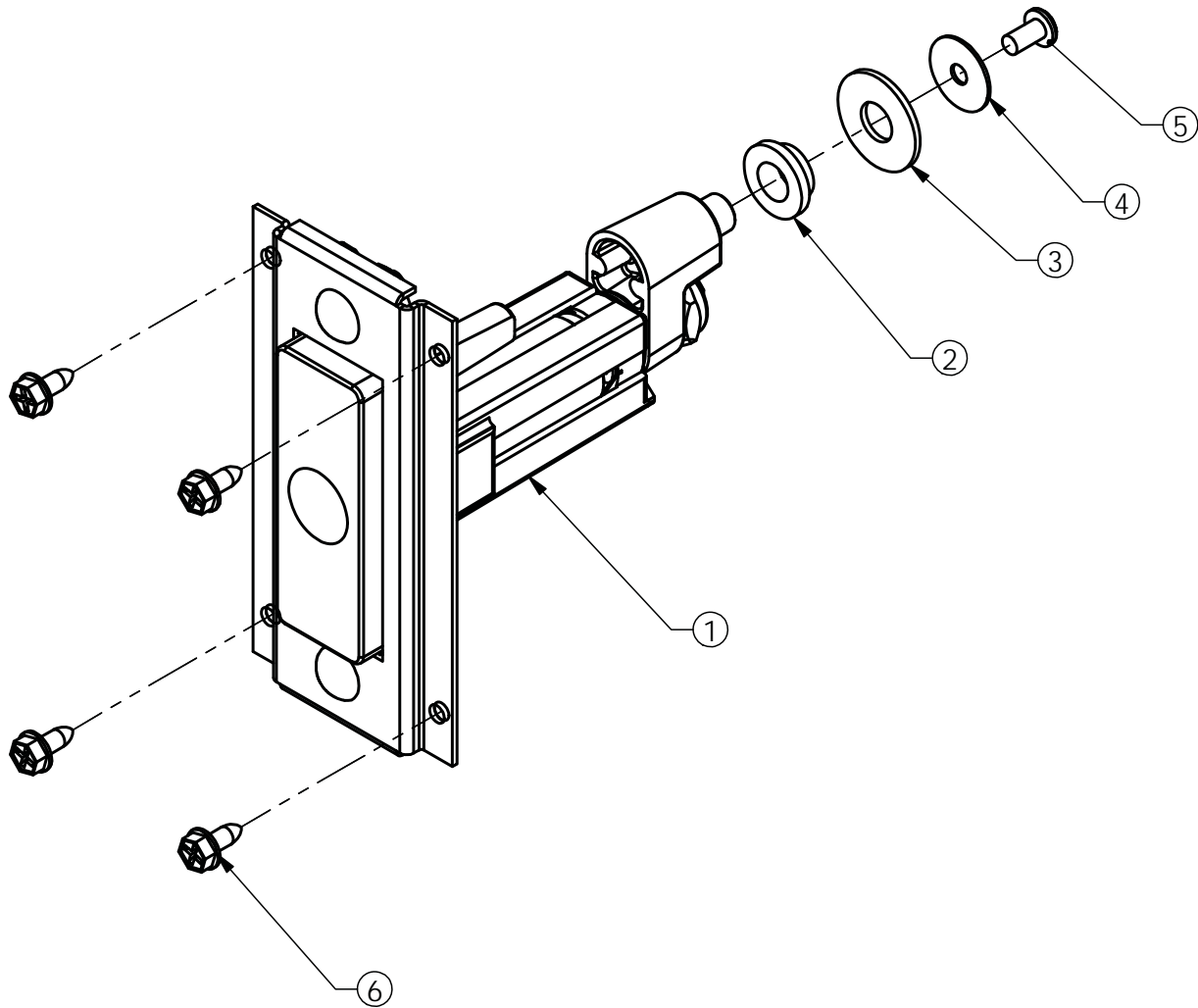

T-HANDLE LOCK ASSEMBLY

ITEM NO	DESCRIPTION	QTY	PART NO
1	T-HANDLE ASSY, GFV	1	1133778
2	SHOULDER SPACER, LOCK CAM	1	1124527
3	WASHER - 3/8, B PLAIN FLAT	1	V801491
4	WASHER,13/64, LEWIS#24082-200	1	389026
5	SCREW -10-32 X .375, CR PAN H STL MACH	1	V800128
6	SCREW - #10 TAPPING - TYPE F	4	V801421



HARNESS QUICK REFERENCE GUIDE

PART NO.	DESCRIPTION	PURPOSE	Vue40	Vue30
1165755	Door Harness	Connects all peripherals to control board	X	X
1161129	Selection Harness - 12 select	Connects the selection buttons to the control board	X	
1163886	Selection Harness - 8 select	Connects the selection buttons to the control board		X
1163357	Light Harness - 2 bulbs	Connects the light bulbs to ballast located inside cabinet	X	
1163369	Light Harness - 3 bulbs	Connects the light bulbs to ballast located inside cabinet		X
1163345	Harness, Cabinet Extension	Connects cabinet to door (SXY40 Only)	X	
1128750	Harness, Low Voltage, Dist.	Located inside power distribution box	X	X
1165548	Harness, High Voltage, Dist.	Located inside power distribution box	X	X
1165767	Grounding, X-Rail V30	Connects x-rail metal parts to ground		X
1165525	Grounding, X-Rail V40	Connects x-rail metal parts to ground	X	
1165501	Harness, Cabinet	Connects cabinet with door	X	X
1165755	Harness, PDC	Connects x-rail to control board	X	X
1165639	Harness, Ballast Asy	Connects ballast to power inputs	X	X

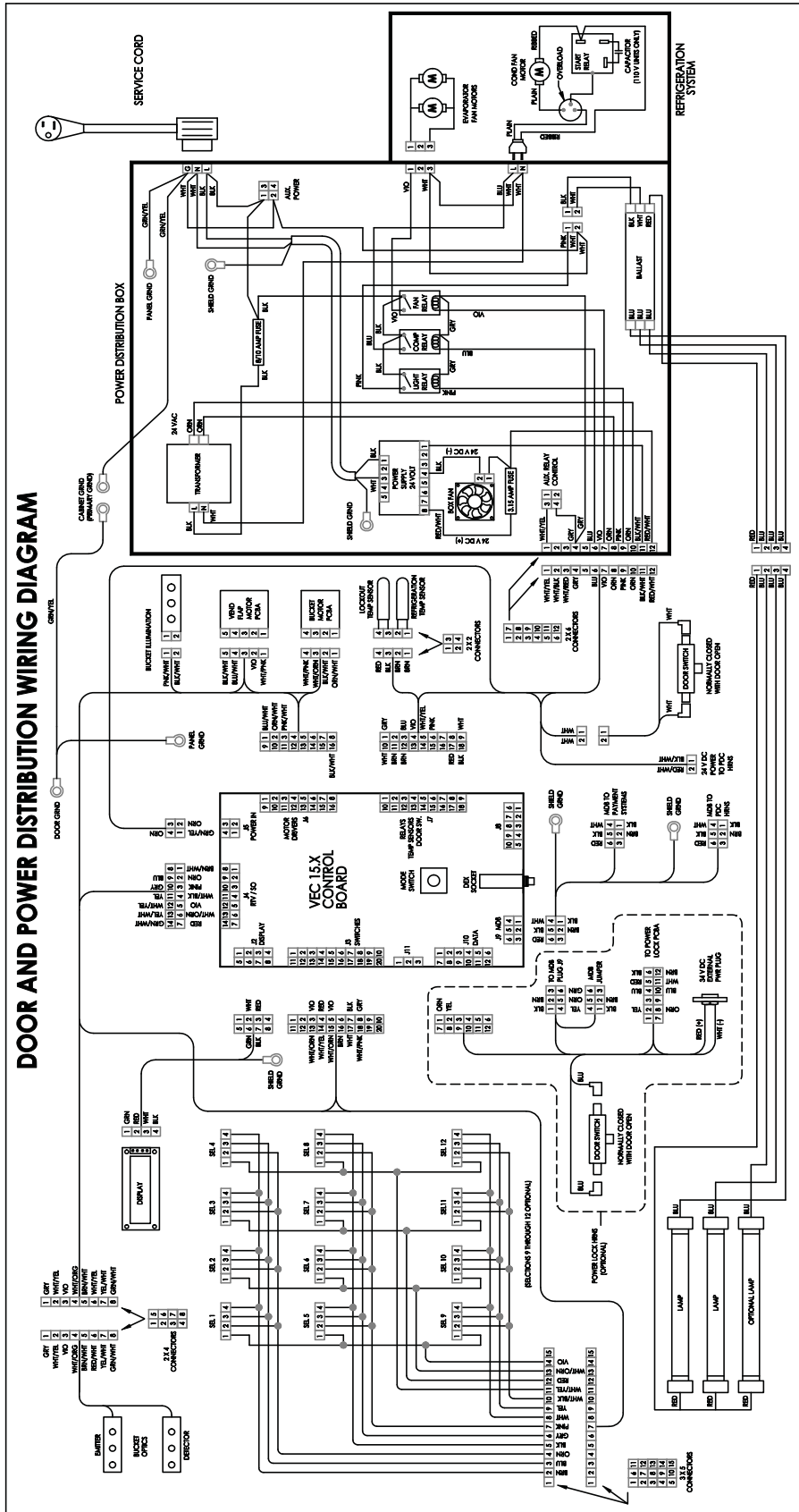



NOTES



SXY

MAINTENANCE SECTION



MAINTENANCE

The following section is a basic guide for general maintenance and servicing of the vendor. This section is divided into three parts: (I) Preventative Maintenance, (II) Lubrication Guide, and (III) Care and Cleaning.

I. PREVENTATIVE MAINTENANCE SUGGESTIONS:

Whenever a vendor is visited on its site, the following service should be performed. Preventative maintenance will help prevent future problems with the vendor.

- A. Observe the vendor and its surrounding area for any unusual indications of problems (rear of cabinet, obstructions of the air flow, condensate puddles, lamp off, etc.).
- B. Open the door and visually check the inside of the vendor (water accumulation, rust marks, moisture around the edges of the door, etc.).
- C. Check the fluorescent lamp, replace as necessary. Replace lamp within 24 to 48 hours of burnout. This will prevent damage to the ballast. *
- D. Check the product temperature for proper cooling.
- E. Check the evaporator drain for obstruction; water in the evaporator area must drain to the condensation pan.
- F. Clean the condenser fins.
- G. Check that evaporator fan runs normally.
- H. Check that the compressor and condenser fan run normally.
- I. Investigate any unusual sounds (fan blades hitting something, refrigeration lines rattling, etc.).
- J. Clean coin acceptor.
- K. Check for proper operation of the coinage mechanism by inserting all denominations of coins accepted by the vendor.
- L. Test the vendor and make a report on the problems.

* NOTE: The VUE vendor features a circuit interrupting style ballast. If the lamp is replaced, you must cycle the power to the machine to bring the light back on.

II. LUBRICATION GUIDE:

Lubricate indicated areas as directed on the chart below.

INTERVALS	PARTS	LUBRICANT
Every six months	Door latch slide mechanism & T-handle assembly	Grade two, high low temperature grease



REFRIGERATION OPERATION

The refrigeration operation section is divided into three areas: Basic Refrigeration Principle, Detailed Vending Machine Refrigeration Cycle, and Parts Description.

BASIC REFRIGERATION PRINCIPLE

What a refrigeration system really accomplishes is the transfer of heat. A refrigeration system removes the excess heat from a refrigerated area and then transfers it to a condenser where it is dissipated. As heat is removed, the refrigerated area cools.

In vending machines, large quantities of the heat must be transferred rapidly, economically and efficiently. This process must be able to withstand continuous repetition, without loss of refrigerant, over an extended period. The most common system used in the vending industry is the vapor compression (or simple compression) cycle system. It consists of four basic elements: An evaporator, a compressor, a condenser, and a pressure-reducing device (all part of a sealed system).

The compression system operates at two pressure levels: The low evaporating pressure and the high condensing pressure. The refrigerant acts as the transport medium, in which heat is moved from the evaporator to the condenser; at the condenser, the heat is dissipated into the surrounding air.

The liquid refrigerant changes from a liquid to a vapor and back to a liquid again. This change of state allows the refrigerant to absorb, and rapidly discharge, large quantities of heat efficiently.

BASIC VAPOR COMPRESSION SYSTEM CYCLE:

In the evaporator, the liquid refrigerant vaporizes. This change occurs at a temperature low enough to absorb heat from the refrigerated space. The temperature of vaporization is controlled by the pressure maintained in the evaporator (the higher the pressure, the higher the vaporization point).

The compressor pumps the vapor from the evaporator, through the suction line, and to the condenser. The compressor takes the low pressure vapor and compresses it, increasing both the pressure and the temperature. The compressor pumps the vapor at a rate rapid enough to maintain the ideal pressure. The hot, high pressure vapor is forced out of the compressor, into the discharge line and then into the condenser.

Air is blown through the condenser, allowing heat to transfer from the condenser and into the passing air. As the heat is removed, the stored refrigerant is condensed into a liquid. The liquid refrigerant is stored in the lower tube of the condenser. This is where it flows through the capillary tube back into the evaporator, where the refrigeration cycle is repeated.



DETAILED REFRIGERATION CYCLE

The following is a detailed refrigeration cycle as it applies to the refrigeration system installed in Vendo equipment. (Refer to the flow chart in Figure 1.)

As the air temperature in the cabinet rises, the electronic temperature sensor reports the air temperature to the electronic controller. The electronic controller actuates the refrigeration control relay, which turns on both the compressor and condenser fan motor.

The evaporator fan pulls air from the front of the refrigerated space of the cabinet. It pulls the air through the evaporator, and blows it up the rear of the vend stack. (The evaporator fan runs continuously.) As the air passes through the evaporator, heat is drawn from the air and transferred to the liquid refrigerant. As the cooled air circulates through the vend stack, heat is drawn from the product and transferred to the circulating air. The heated air is again drawn through the evaporator where the heat is removed.

In the evaporator, the liquid refrigerant draws heat from the circulating air. As refrigerant receives heat, it vaporizes.

The compressor pumps the vapor from the evaporator and compresses it, increasing both pressure and temperature. The compressor forces the compressed vapor out, through the discharge line and into the condenser.

The condenser fan pulls air through the condenser. As the hot refrigerant vapor passes through the condenser tubes, heat is drawn from the vapor. This heat is dissipated into the passing air. The air then exits out the back of the vendor. As the refrigerant vapor in the condenser lines is cooled, it returns to a liquid state.

From the condenser the liquid flows to the drier. The drier removes any water and solid particles from the liquid refrigerant.

The cooled liquid refrigerant continues from the drier, through the capillary tube, to the evaporator. The capillary tube steadies the flow rate of the refrigerant. Its small inside diameter allows the pressure in the evaporator to remain low while the pressure in the condenser is high.

The cool refrigerant in the evaporator draws heat from the circulating air in the cabinet. As the temperature in the cabinet drops, the electronic temperature sensor reports the air temperature to the electronic controller. The electronic controller deactivates the refrigeration control relay, which turns off the compressor and condenser fan motor.

When the air temperature in the cabinet rises above the electronic controller's cut in setting, the compressor and the condenser fan engage again.

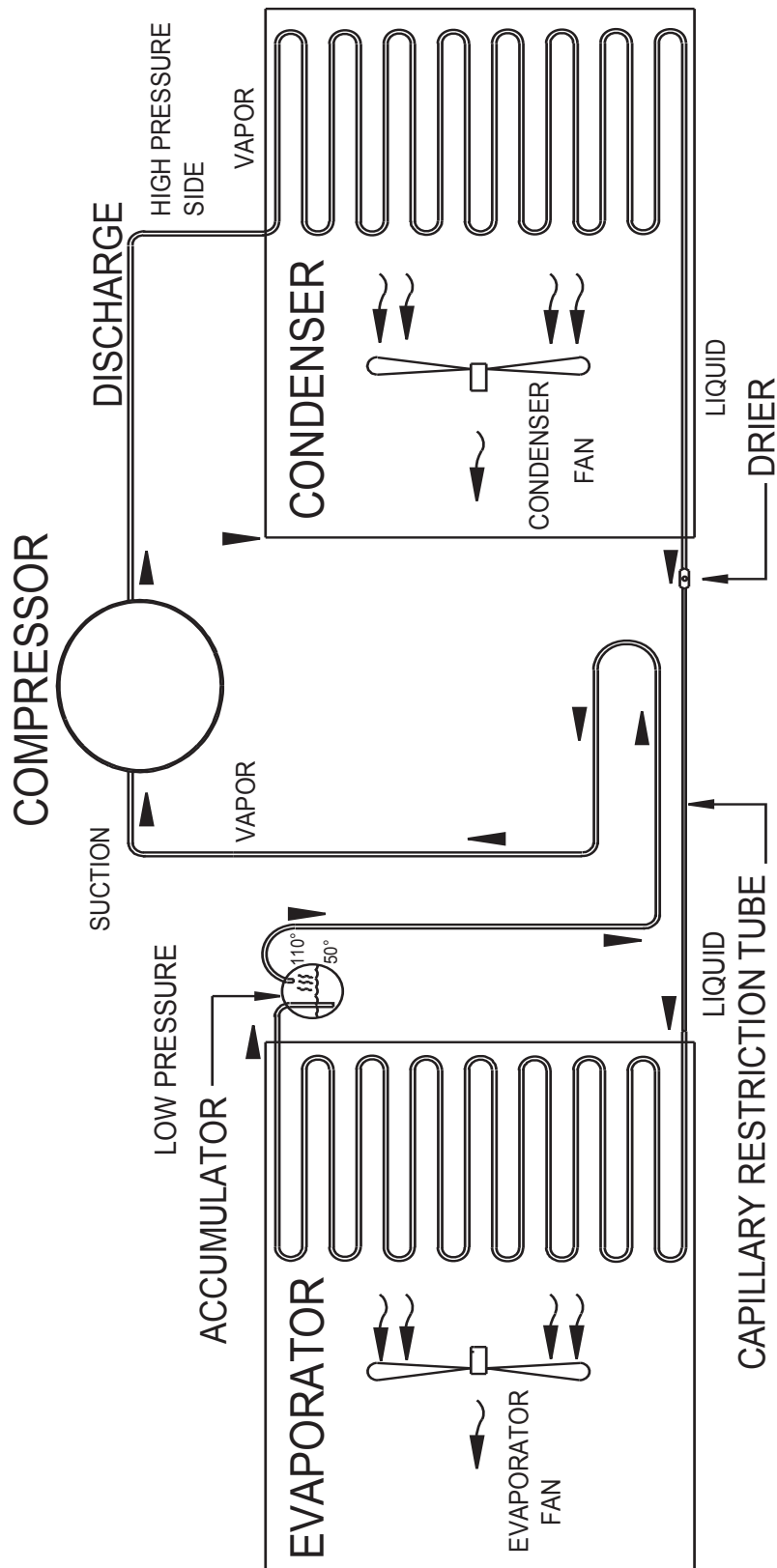

FIGURE 1



REFRIGERATION PARTS DESCRIPTION

The compressor, condenser, drier, capillary tube, evaporator, and accumulator are part of a sealed system (refer to Figure 2). These items are not available separately.

COMPRESSOR

The compressor takes in low pressure vapor and compresses it, increasing both the pressure and the temperature. The hot, high pressure gas is forced out to the condenser. The compressor and the motor that drives the compressor are sealed inside a housing. The compressor, as a unit, is mounted on the refrigeration base. The base is mounted in the bottom of the vendor, outside the sealed refrigeration space.

CONDENSER

The condenser takes heat out of the high pressure vapor that it receives from the compressor. As the vapor passes through the condenser it cools and returns to a liquid state. The condenser is mounted to the refrigeration base near the front of the vendor. It is easily accessible for cleaning.

FILTER/DRIER

The drier is a molecular sieve strainer drier. It removes water and solid particles from refrigerant liquid. One side of the drier is connected to the outlet line of the condenser; the other side is connected to the capillary tube going to the evaporator.

CAPILLARY TUBE

The capillary tube controls, at a steady rate, the flow of refrigerant liquid to the evaporator. It has a very small inside diameter to keep pressure in the evaporator low while the pressure in the condenser is high. It is the connecting link between the condenser and evaporator.

EVAPORATOR

The evaporator is a heat transference device. It removes the heat from the air in a refrigerated space and transfers it to the refrigerant liquid. This liquid evaporates into a vapor and is removed by the compressor. The evaporator is mounted inside the refrigerated space of the cabinet, directly below the delivery chute.

ACCUMULATOR

The accumulator traps any refrigerant liquid, which did not boil off into a vapor before reaching the compressor. The accumulator allows the refrigerant liquid to boil off as a vapor (preventing damage to the compressor). It also prevents suction line sweating. The accumulator is mounted in the suction line on the outline side of the evaporator.

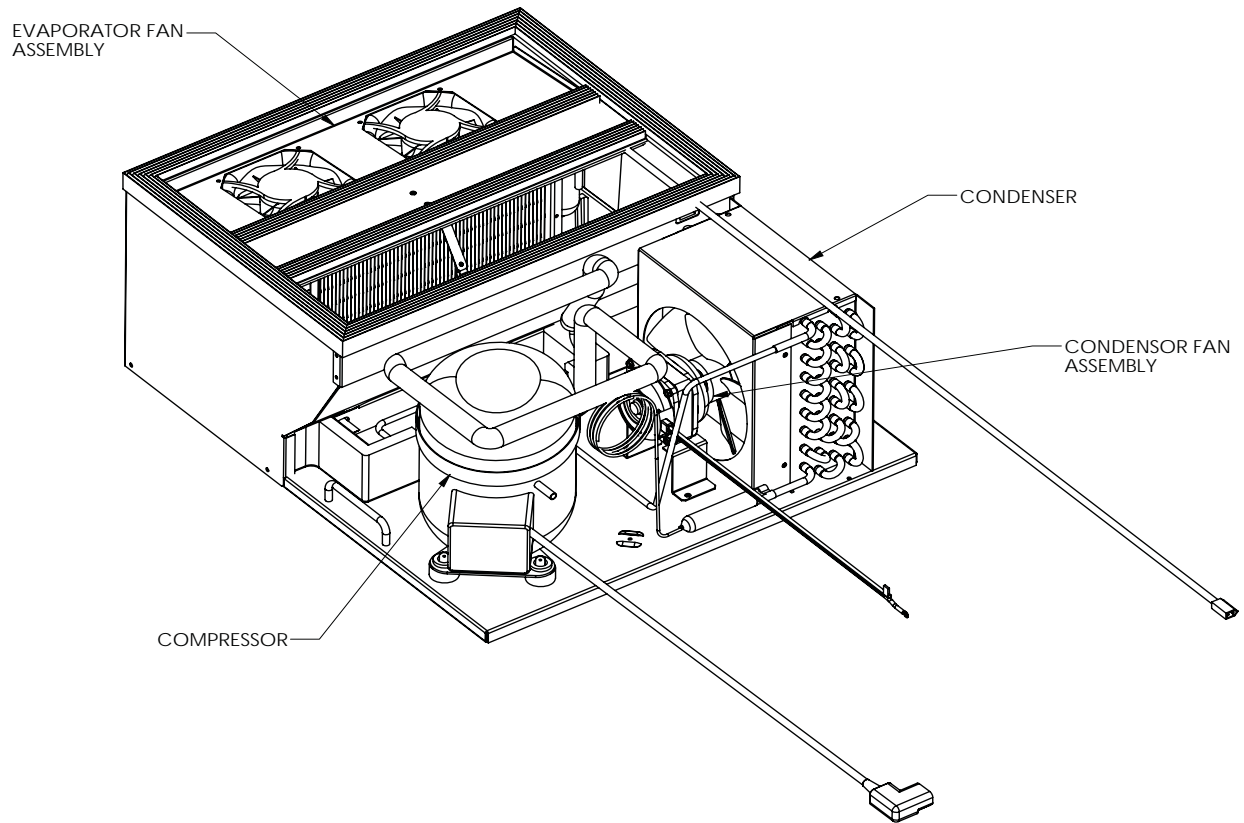

FIGURE 2



The parts listed below are not part of the sealed refrigeration system and are available separately.

START CAPACITOR - P/N: 1122999

The start capacitor is used to increase power during the start. This additional power will help get the compressor running in case there is any back pressure.

STARTING RELAY – INCLUDED IN ASSEMBLY P/N 513506066

The starting relay is mounted in the terminal box on the outside of the compressor under the housing. When the compressor first starts up, the starting relay closes and completes a starting circuit. When the compressor motor reaches operating speed, the starting relay opens and breaks the starting circuit.

THERMAL OVERLOAD SWITCH – INCLUDED IN ASSEMBLY P/N 513506066

The thermal overload switch is mounted in the terminal box on the outside of the compressor under the housing. If the compressor motor gets hot or draws too much current, the thermal overload opens and breaks the starting and running circuit of the motor. As the motor cools, the thermal overload closes, allowing the compressor to restart.

TEMPERATURE SENSOR – P/N 1122924

The temperature sensor is mounted in the inlet airflow of the evaporator. This monitors the air temperature and reports it to the electronic controller so that the controller can operate the refrigeration system via the power box.



NOTES



SXY

TROUBLESHOOTING SECTION



PARTS RETURN PROCEDURES

1. All parts returned must be accompanied by a material return tags (P/N 1122825) Tag must clearly state the reason for the return and the Return Goods Authorization Number received from your Vendo Customer Service Rep at 1-800-344-7216. (Return tags are available from our parts department upon request).
2. All parts should be properly wrapped and packed securely to avoid further damage.
3. To replace an inoperative part, please use the following instructions
4. Complete the return tag making sure to fill in ALL requested information to ensure prompt processing. Keep top (white) copy for your records. Attach tag to inoperative part and send it by the most inexpensive method of transportation (Federal Express Ground or Overnight Transportation) **To: SandenVendo America, Inc., 10710 Sanden Drive, Dallas, Texas 75238.**
5. Be sure to check () the box marked "credit" and to fill in the invoice number covering the part sent to you or check the box marked "replace with like part".
6. If the box is marked for replace with like part, a like part will be shipped at no charge if our inspection shows that the inoperative part became defective during the warranty period.
7. If the box is marked for credit, a credit will be issued to cancel the invoice on which the replacement part was shipped. This credit will include any applicable prepaid transportation charges. To receive credit the inoperative part must be returned within 30 days from the date the replacement was shipped.
8. Vendo does not issue cash credit for the return of any part or accessory.

REFRIGERATION UNIT RETURN PROCEDURE

1. All refrigeration units returned must be accompanied by a material return tag (P/N 1122826). Tag must clearly state the reason for the return and the Return Goods Authorization Number received from your Vendo Customer Service Rep at 1-800-344-7216. (Return tags are available from our parts department upon request).
2. All refrigeration units should be properly wrapped and packed securely to avoid further damage.
3. To replace an inoperative part, please use the following instructions.
4. Complete the return tag making sure to fill in ALL requested information to ensure prompt processing. Keep top (white) copy for your records. Attach tag to inoperative part and send it by the most inexpensive method of transportation (Federal Express Ground or Overnight Transportation) **To: SandenVendo America, Inc., 10710 Sanden Drive, Dallas, Texas 75238.**
5. Be sure to check () the box marked "credit" and to fill in the invoice number covering the part sent to you or check the box marked "replace with like part".
6. If the box is marked for replace with like part, a like part will be shipped at no charge if our inspection shows that the inoperative part became defective during the warranty period.
7. If the box is marked for credit, a credit will be issued to cancel the invoice on which the replacement part was shipped. This credit will include any applicable prepaid transportation charges. To receive credit the inoperative part must be returned within 30 days from the date the replacement was shipped.
8. Vendo does not issue cash credit for the return of any refrigeration unit.

***Canadian and International customers please contact your Customer Service Representative for return instructions**

The VUE 30/40 vendor provides self-diagnostics to aid you in the trouble shooting process. Error codes are stored in the controller's memory when a system error is sensed. These codes can be accessed in the Diagnostic section of Programming.

The trouble shooting section contains Error Codes (version 15) and General Machine Troubleshooting.

Error Codes (version 15)

ERROR	DESCRIPTION OF ERROR CODE	CHECKING METHOD	CORRECTIVE ACTION
Vending Mechanism - PDC Error (Hand Control Board)			
X-motor Jam	X motor portion of vending mechanism did not start or complete.	System Check: If unit does not move, check the LED in the lower left hand side of PDC. It should be a constant red light. If LED is not on, unplug machine, check fuse on power distribution panel. Check two pin power connector in bottom of door. Check connection to board on X rail. Check power connection in PDC. Check power supply connections in power distribution panel. Check LED on power supply in power distribution panel. Check fuse on power supply in power distribution panel.	Replace fuse(s) if necessary. Plug in machine. Complete a test vend cycle.
		If unit has not returned to the home position, check to see if hand is jammed on tray or other item in cabinet.	Clear jam, unplug machine, wait 5 seconds and plug machine back in. If hand goes back home after auto recovery, run X motor in Test Motors. Complete a test vend cycle. If hand does not go home in X, replace X motor.
		If unit has returned to the home position, hand jammed but was able to recover. Check product positions to determine if any are sold out with product still in column.	Complete a test vend cycle of sold out products. If hand hits tray in X, adjust X home position.
Y-motor Jam	Y motor portion of vending mechanism did not start or complete.	Perform System Check, see X-Motor Jam.	Replace fuse(s) if necessary. Plug in machine. Complete a test vend cycle.
		If unit has not returned to the home position, check to see if hand is jammed on tray or other item in cabinet.	Clear jam, unplug machine, wait 5 seconds and plug machine back in. If hand goes back home after auto recovery, run Y motor in Test Motors. Complete a test vend cycle. If hand does not go home in Y, replace Y motor.
		If unit has returned to the home position, hand jammed but was able to recover. Check product positions to determine if any are sold out with product still in column.	Complete a test vend cycle of sold out products. If hand hits tray in Y, run Discovery 2.
Z-motor Jam	Z motor portion of vending mechanism did not start or complete.	Perform System Check, see X-Motor Jam.	Replace fuse(s) if necessary. Plug in machine. Complete a test vend cycle.
		If unit is extended in Z check Z housing ribbon cable to be sure it is plugged in.	Unplug machine. Plug in Z housing ribbon cable. Plug machine back in. If hand goes back home after auto recovery, run Z motor in Test Motors. Complete a test vend cycle.
		If product is in hand, look to see if product is stopping the hand from closing.	Remove product from hand. Unplug machine, wait 5 seconds and plug machine back in. If hand goes back home after auto recovery, run Z motor in Test Motors. Complete a test vend cycle.
		If unit has returned to the home position, hand jammed but was able to recover. Check product positions to determine if any are sold out with product still in column.	Complete a test vend cycle of sold out products. If hand hits tray front, run Discovery 2. If hand jams on center gate, reduce Z Product Position by 3 encodings.
Clamp-motor Jam	Clamp motor portion of vending mechanism did not start or complete.	Perform System Check, see X-Motor Jam.	Replace fuse(s) if necessary. Plug in machine. Complete a test vend cycle.
		Look at clamp fingers to see if only partially open.	Clamp motor has failed. Replace clamp motor.

ERROR	DESCRIPTION OF ERROR CODE	CHECKING METHOD	CORRECTIVE ACTION
Jam - Recovered	The unit encountered a jam condition while vending. It was able to recover from the jam and return to home. The user was requested to select a new product.	Check product positions to determine if any are sold out with product still in column.	Complete a test vend cycle of sold out products. If hand hits tray front, run Discovery 2. If hand jams on center gate, reduce Z Product Position by 3 encodings.
Failed Movement	This is a non jam failure. A motor function failed to complete.	Depends on movement attempted. If Discovery, check reflectors.	Check Motors Movement in Test Mode and regular Vending. Check all Sensors under Check Sensor Status. Install any missing reflectors.
X-Rail Not Level	During a Discovery 2 operation, the X rail was higher on one side by more than 1 inch.	Unplug machine. Move the X rail manually to the center of the machine opposite a shelf. Close the door. Look along the bottom of the rail at the trays. Determine which side is higher.	Remove the X-rail cap. On the latch side of the machine, release the Y gear coupling. Move the X-rail down until it is level. Recheck. Run Discovery 2.
FLOAlways On	During a target search operation, the Forward Looking Optic (FLO) was found to be always active.	Test Flo with a corner-cube reflector piece. The device has two lights. The green light should be on. When the reflector is in front of the Flo, the second light should change from off to orange. Check reflectors along latch side trays. FLO may have only seen the shelf 4 reflector during scan. Verify X Home aligned with latch side reflectors.	If the green light is off, check the plug on the PDC. If the orange light does not turn on and off, replace the FLO assembly. If the Flo does turn on and off replace the PDC board.
FLOAlways Off	During a target search operation, the Forward Looking Optic (FLO) was found to never activate.	Check power on the FLO device. The green light should be on. Test Flo with a corner-cube reflector piece. When the reflector is in front of the Flo, the second light should change from off to orange. May not have seen any reflectors on latch side. Check reflectors along latch side trays.	If the green light is off, check the plug on the PDC. If the orange light does not turn on and off, replace the Flo assembly. If the Flo does turn on and off replace the PDC board. Make sure door properly closed.
Missing Coordinates	During a Discovery operation, an expected, required tray reflector was not found	1) Check reflectors on top shelves. 2) Check all reflectors on latch and hinge side trays are installed. Check power on the FLO device. The green light should be on. Test Flo with a corner-cube reflector piece. When the reflector is in front of the FLO, the second light should change from off to orange. Check top and bottom shelves are properly seated on the base metal.	Install any missing reflectors. If the green light is off, check the plug on the PDC. If the orange light does not turn on and off, replace the FLO assembly. If the Flo does turn on and off replace the PDC board. Reseat tray firmly in shelf
Missing Tray	Used in Discovery 3 and 4. A required tray is missing on the top or bottom shelf.	Check all reflectors on top and bottom shelves.	Install any missing reflectors.
Shelf ends Mismatch	During a Discovery operation, the number of shelves in the latch side did not match the shelves on the opposite side of the machine.	Check all tray positions. Make sure each tray has a corner-cube reflector in the center tray pocket. Check all side trays are fully seated in shelves.	Replace any missing tray reflectors. Run Discovery 2. Reseat tray firmly in shelf. Run Discovery 2.
Shelf Not Level	During a Discovery operation, one or more shelves was found to vary in position more than 1 inch from the hinge side to the latch side.	Check all tray positions. Make sure each tray is fully seated on the shelf.	Reseat tray firmly in shelf.

ERROR	DESCRIPTION OF ERROR CODE	CHECKING METHOD	CORRECTIVE ACTION
Failed Communication	PDC failed to communicate with VMC.	<p>Check all harnessing between PDC and VMC.</p> <p>Check LED's on PDC. Lower right hand light should have heartbeat. Green heartbeat = PDC not receiving communication from VMC. Orange heartbeat = PDC both receiving and transmitting communication.</p> <p>Red heartbeat = PDC closed communication.</p> <p>No heartbeat (LED off or solid color LED) = PDC not operating. If no heartbeat, check FLO power indicator (should be solid green).</p>	<p>Unplug machine. Reset any loose pins in harnesses. Reseat reset harness plugs. Plug in machine.</p> <p>If Green or Orange heartbeat, check MDB communication cable connections as above.</p> <p>If Red heartbeat, PDC has logic error. Unplug machine, wait 5 seconds and plug machine back in.</p> <p>If no heartbeat, LED is off and Flo power indicator is off, the PDC does not have power. Check the heartbeat on the VMC. If the VMC is powered, check the MDB cables. If no heartbeat and the Flo power indicator is on a problem with the software flash chip may be likely. Replace the flash chip. If this does not fix the problem, replace the PDC.</p>
Failed Unknown	An error occurred that did not conform to any known error.	<p>Check all harnessing between PDC and VMC.</p> <p>Check LED's on PDC. Lower right hand light should have heartbeat. Green heartbeat = PDC not receiving communication from VMC. Orange heartbeat = PDC both receiving and transmitting communication.</p> <p>Red heartbeat = PDC closed communication.</p> <p>No heartbeat (LED off or solid color LED) = PDC not operating. If no heartbeat, check Flo power indicator (should be solid green).</p> <p>Run Vending motors in Test Motor. Check health of sensors in Test Mode Check Sensors.</p>	<p>Unplug machine. Reset any loose pins in harnesses. Reseat reset harness plugs. Plug in machine.</p> <p>If Green or Orange heartbeat, check MDB communication cable connections as above.</p> <p>If Red heartbeat, PDC has logic error. Unplug machine, wait 5 seconds and plug machine back in.</p> <p>If no heartbeat, LED is off and Flo power indicator is off, the PDC does not have power. Check the heartbeat on the VMC. If the VMC is powered, check the MDB cables. If no heartbeat and the Flo power indicator is on a problem with the software flash chip may be likely. Replace the flash chip. If this does not fix the problem, replace the PDC.</p> <p>Unplug machine. Replace any malfunctioning motors or sensors. Plug the machine back in.</p> <p>Reboot the machine.</p> <p>If problem exists, change the PDC and VMC software.</p>
Setup Flash Write Failed / Setup Flash Write Failed	Changes to the configuration could not be stored in PDC's FLASH chip.	Reboot the machine.	<p>1) (In factory), if never able to program FLASH, the FLASH may be misconfigured (Fujitsu chip has Sector 7 protect on)</p> <p>2) Random Failure: Cold reboot GFV and try again.</p> <p>3) FLASH chip has failed or worn out (after many thousands of uses). Replace FLASH chip with new. The FLASH chip holds the software, so it is the PDC software chip. Don't forget to save relevant parts of PDC's configuration.</p> <p>4) If FLASH chip change does not work (try more than once, using care to install chip without damage), there may be a failure in the PDC circuitry. Replace PDC board.</p>
Failed Conformation	Discovery 1 scanned the latch side of the GFV and the shelves discovered do not match those stored in FLASH. Shelf configuration changed.	Machine will automatically perform Discovery 2.	Run Discovery 2. If no changes were made to the trays/shelves in GFV, may indicate a missing reflector.
Inappropriate Command	Test/Config Mode command received while not in Test/Config Mode. Ex. Test Motors command received while the machine is vending.	PDC will automatically ignore the inappropriate command.	

ERROR	DESCRIPTION OF ERROR CODE	CHECKING METHOD	CORRECTIVE ACTION
Command Out of Sequence	The MDB command received is inappropriate for the current state of the PDC. Ex. example, if the Vend Drop command were received when the hand is not waiting at the hopper to drop a product during a Vend, Startup, or Recovery.	PDC will automatically ignore the command.	
Command in Progress	Test/Config Mode command received while already executing a Test/Config command.	PDC will automatically ignore the command.	
Command Data Out of Range	Test/Config Mode command received that is either an invalid command number or has a parameter that is out of range for that parameter.	VMC will retry sending the command to PDC	
Command Denied Safely	A command was rejected because it is unsafe. A Test/Config Z Movement command was rejected because the PDC thinks the hand is in the pocket at the bottom of the machine.	PDC will automatically ignore the command.	
Shelf Invalid	Test/Config commands that have a shelf number as a parameter can return this error for a shelf number, while in range, which identifies a shelf that does not exist (was not found during discovery).	Performing Calibrations / Set Z corrections without rumming discovery can lead to this error.	Run Discovery 2 before performing Calibration or Corrections.
TC Failed Movement	1. When any one of the following movements in X, Y, Z or Clamp fail during Test Motors. 2. When any of the sensors fails. (i.e. X, Y, Z, Clamp or Forward Looking Optics Sensors)	1. Check to see if the X, Y, Z or Clamp movements are performed. On Exit from Test Motors the X, Y, Z and clamp should be at home position. 2. Check the Sensors. (O denotes good sensor. If the sensor is blocked - then change the respective sensor)	Run Test Motors and Get Sensor Status after performing the checking method.
Vending Mechanism - VMC Error			
Hop Flap No Current	Hopper flap motor either did not run, or no current was detected.	Check Hopper flap harness connection. Run Test Hopper Flap in Test Mode	Plug in hopper flap connector. Run Test Hopper Flap in Test Mode. If motor moves, current detection circuitry has been damaged on VMC. Replace VMC board.
Hopper Flap Jam	VMC detected high current while running the Hopper Flap motor without detecting the Hopper flap positioning switch.	Run Test Hopper Flap in Test Mode Check to see if product is jamming the Flap	If motor does not move, replace Hopper Flap motor. Remove the product. Run Hopper Flap Test.

ERROR	DESCRIPTION OF ERROR CODE	CHECKING METHOD	CORRECTIVE ACTION
Hop.Buck No Current	Hopper Bucket motor either did not run, or no current was detected.	Check Hopper Bucket harness connection. Run Test Hopper Bucket in Test Mode	Plug in hopper bucket connector. Run Test Hopper Bucket in Test Mode. If motor moves, current detection circuitry has been damaged on VMC. Replace VMC board.
Hopper Flap Jam	VMC detected high current while running the Hopper Bucket.	Run Test Hopper Bucket in Test Mode	If motor does not move, replace Hopper Bucket motor.
Hopper Flap Switch	Hopper flap motor runs but does not detect the home switch.	Check to see if product is jamming the Bucket Run Test Hopper Flap in Test Mode	Remove the product. Run Hopper Bucket Test. Replace hopper flap motor assy.
Hopper Bucket Switch	Hopper bucket motor runs but does not detect the home switch.	Run Test Hopper Bucket in Test Mode	Replace the hopper bucket motor assy.
Selection Switches - Keypad			
Stuck Selection SW on Keypad	Bad Selection Switch - Selection switch within the Keypad is actuated for more than 15 seconds while in the Customer Mode or Door Open Sales Test Mode.	Check the selection switch number shown in the detailed error code "nm" to see if: 1) if the Keypad is defective; 2) the harness is wired wrong/shorted	Try to correct the problem if one of the two items are found. If you can't correct it, then replace the component in question.
Coin Changer			
Coin Communication	Changer communication error - no changer communication for more than 2 seconds.	Check that red light is flashing on control board. Check fuse on the power distribution panel. Defective acceptor.	If light is not flashing, there is no power to board. Check and replug any unplugged connections. If fuse is blown replace it. Replace transformer. Replace acceptor.
Tube Sensor	Tube sensor is defective -- reported by changer.	Check changer tubes for blockage	Clear tube blockage. If no blockage is found, replace changer.
Coin Inlet	Changer inlet chute blocked - no coins sensed for over 96 hours by the changer.	Check inlet chute for blockage. Drop coins in Sales Mode or Tube Fill Mode to test acceptance. Manually clear the error.	Clear inlet chute blockage. If no blockage found, replace changer. If acceptance rate is acceptable, system is OK. If acceptance rate is low or changer will not accept coins, replace changer.
Tube Jam	Tube pay out jam -- reported by changer.	Check changer tubes and payout for blockage.	Clear blockage, if found. If no blockage is found, replace changer.
Coin Read Only Memory	Changer check sum incorrect -- reported by changer.	Unplug machine, wait at least five seconds, replug machine. Manually clear the error	If error does not clear, replace changer/acceptor. Replace acceptor
Excessive Escrow	Excessive escrow requests -- more than 255 requests since the last coin was sensed.	Check escrow lever and associated mechanisms. Close door then reopen. Check to see if error still occurs.	Manually clear the lever and error. Replace changer/acceptor.
Coin Jam	Coin jam - reported by changer	Check changer/acceptor for jammed coins or other obstructions.	If no obstructions are apparent, replace changer/acceptor
Low Acceptance	Low acceptance rate -- coin acceptance has fallen below 80%	Check changer/acceptor for obstructions or dirt	If no obstructions are apparent, and acceptance appears to be OK, this may be an indication of cheating attempts.
	Drop coins test acceptance.		If no obstructions are apparent and coins do not accept, or acceptance rate is poor, replace changer/acceptor.

ERROR	DESCRIPTION OF ERROR CODE	CHECKING METHOD	CORRECTIVE ACTION
Accept/Disconnect	Disconnected acceptor -- indicates that an acceptor is unplugged.	Check coin mechanism plugs. Check for faulty harness wiring (see wiring diagram for circuit).	Correct connections.
Routing	Coin routing - indicates a coin was routed incorrectly.	Verify acceptor set-up using manufacturer's recommendations.	If acceptor was set up correctly, replace acceptor.
Dollar Bill Validator			
Bill Validator Communication	Bill validator communications - No bill validator communication for 5 seconds.	If changer or card reader is being used, check for "CC" or "rC" errors. Turn off door switch and wait at least five seconds. Turn on door switch.	If there are no "CC" or "rC" errors: 1) Check bill acceptor harness; 2) Replace bill acceptor. If there is a "C" or "rC" error: 1) Check control board MDB harness.
Bill Validator Full	Bill validator full - reported by validator (STACKER command).	Insure bill cashbox is empty and that the cashbox is properly closed and in place.	If cashbox appears to be OK, replace bill acceptor.
Bill Validator Motor	Bill validator motor is reported as defective by validator.	No test available	Replace bill acceptor.
Bill Validator Jammed	Bill jammed -- reported by validator.	Check bill validator for obstructions or dirt.	If no obstructions are apparent, replace bill validator.
Bill Validator ROM	Bill validator check sum is incorrect.	Turn power switch off. Wait at least five seconds. Turn power switch on. Manually clear the error.	If error does not clear, replace bill acceptor.
Bill Validator Open	Bill validator is open.	Check that bill cashbox is closed and in correct position.	If cashbox appears to be OK, replace bill acceptor.
Bill Validator Sensor	Bill validator sensor is not functioning.	Check bill validator for obstructions or dirt.	If no obstructions are apparent, replace bill validator.
Card Reader			
Card Reader Communication	There is no card reader communication for 5 seconds.	If card reader/bill acceptor is being used, check for "rC" or "bC" errors.	If there is no "rC" or "bC" error: 1) Check changer harness. 2) Replace changer.
Card Reader	Most recent "non-transient error" from the card reader.	Turn power switch off. Wait at least five seconds. Turn power switch on. No test available.	If there is a "C" or "bC" error: 3) Check control board MdB harness. Refer to card reader manual for corrective action.
Refrigeration			
Temp Sensor	The temperature sensor is defective or unplugged.	Check to see that temperature sensor harness is plugged into door harness at air dam area.	If the sensor is unplugged, replug it.
Compressor	System has failed to decrease temperature 1° per hour while the compressor is running.	Check for temperature sensor connection J7 on control board is plugged in. Check refrigeration settings (refer to refrigeration section of programming manual).	If the connection is unplugged, replug it. Change settings as required.
		Check if evaporator is frozen.	Check seal around cabinet.
		Verify evaporator fan is running.	Check harness to fan motor and check output voltage.
Miscellaneous Problems			
Door Switch	Outer door has been open for more than one hour.	Check the vendor's door switch to see if it's sticking or miswired.	Replace the door switch, if defective.

ERROR	DESCRIPTION OF ERROR CODE	CHECKING METHOD	CORRECTIVE ACTION
Ram Error	Ram check sum for service mode settings stored in non-volatile memory has been corrupted.	No test available.	If error shows up frequently, replace the control board.
AC Low	AC voltage to the controller is less than 20Vrms for more than 30 seconds.	Check for low voltage at the wall outlet at unit start-up.	Contact a qualified electrician.
Scale	Scaling Factor error - one of the credit peripherals has introduced a scaling factor that is not compatible with the current configuration.	Check the connections of changer harness; make sure changer is plugged in and working.	Make corrections to harness or replace the changer if necessary.
Inlet Sensor	Machine's coin inlet sensor is blocked for more than 1 minute.	Check changer harnessing for cut, pinched or crimped wires.	Replace harnesses or changer.
Escrow Return Mech.	3 successive coins are detected at the inlet but do not make it into the changer in 10 seconds.	Check inlet for blockage. If nothing is found, check changer harnessing for cut, pinched or crimped wires.	Clear blockage or replace harness or changer.

General Machine Troubleshooting

ERROR	PROBABLE CAUSE	CORRECTIVE ACTION
COIN ACCEPTANCE/PAYOUT (Record all errors for reference if Vendo Technical Service is required)		
Coin mechanism will not accept coins.	No power to control board. Harness from coin mech to board is cut or disconnected. Short in coin mechanism. Acceptor is dirty or other problem may exist (not tuned). Defective control board.	Check to make sure the red LED on the control board is flashing red. If flashing, check MDB harness connections. If connections are good, replace changer. Use a meter and check each wire for continuity and ground. Replace coin changer/acceptor. Clean acceptor or contact your local coin mech dealer. Replace control board.
No acceptance or rejects a percentage of good coins.	Coin return lever pressing down on acceptor's coin plunger. Acceptor is dirty or foreign matter is in the path. Coin changer is improperly tuned (if tunable). Defective controller board.	Make sure changer is mounted correctly and the coin return lever is in the proper position. Clean acceptor or contact dealer. Contact manufacturer for tuning. Replace/test controller.
Always accepts coins but gives erratic/no credit.	If NO CREDIT: Defective harness between coin mech and control board (will have "CC" error). If ERRATIC OR NO CREDIT: Acceptor or coin mech. If NO CREDIT: Defective controller.	Check harness for cut wires or wrong/bad connections. Test each wire for continuity or test to ground. If found to be defective, replace. Replace coin mech and test. Replace/test controller.
Changer will not payout coins.	Defective harness between coin mech and control board. Defective coin mech. Defective controller board.	Test vendor's manual coin payout. If vendor won't pay out using the Coin Payout mode or during sales, check harness for cuts, bad continuity or wrong connections. If defective, replace and test. Replace coin mech and test. If coin mech won't payout coins manually in the Coin Payout mode or during the Sales Mode and the above two procedures have failed, replace the control board and test payout both in the Coin Payout mode and during a sale.
BILL ACCEPTANCE		
Bill Acceptor will not pull bill in.	Changer payout buttons are disabled while door is closed or while in Open-Door Sales Mode. No power to validator. Acceptance disabled by coin mech (if present), or bad harnessing. Coin mech is not operative. Replace acceptor and test.	Enter the Service Mode or access the Coin Payout Mode. Unplug power. Wait for 10 seconds. Reconnect power and see if bill acceptor cycles. If not, check acceptor harnessing or replace the bill acceptor. Make sure that the coin mech is plugged in (accepts coins) and that the coin tubes have enough coins to enable bill acceptance. Make sure that the changer harnessing is correctly connected and has continuity. Repair or replace if necessary. If acceptor accepts, bill acceptor was defective.

ERROR	PROBABLE CAUSE	CORRECTIVE ACTION
Bill acceptor takes a bill but does not establish credit.	Defective acceptor harness (credit not getting from acceptor to control board through the harness).	Make sure that the acceptor and harnessing is correct for your style of acceptor and it is plugged in and wired properly.
Bill acceptor takes a bill and credits but not erasing credit.	Defective acceptor.	Replace/test acceptor.
Bill acceptor takes a bill and credits but not erasing credit.	Defective controller.	Replace/test controller.
Bill acceptor takes a bill and credits but not erasing credit.	Defective bill acceptor.	Replace acceptor and test acceptance and erasure of credit.
Bill acceptor takes a bill and credits but not erasing credit.	Defective controller.	Replace/test controller for erasure of credit.
Accepter takes a bill and allows payback of coins without a selection.	Both vend sensors are defective	Replace vend sensor.
Accepter takes a bill and allows payback of coins without a selection.	Controllers configurations not set properly.	Access vendor configuration mode and check the "Forced Vend" setting.
VENDING PROBLEMS		
Hand not in home position	Communication error between VMC and PDC or PDC software error	Cycle power to unit. Start-up routine should begin.
Hopper is open	Vend optics blocked	Enter Test Mode check Vend Detection (see service manual). Cycle power to unit. Start-up routine should begin. Replace/Test vend optics.
No vend upon selection.	No power or communication to hand.	Check for lights on hand. Left side red light (motor power) right side flashing (logicpower/ communication). If no light than check MDB connection on VMC.
Hand not aligned correctly to tray when vending.	Tray or shelf out of position (not seated). Tray table in the PDC not present or correct.	Reseat tray or shelf. Run calibration #1 then #2.
X-rail not moving, product in hand.	Vend flap motor unplugged or linkage broken.	Test vend flap in Test Mode. Replace if broken.
Completely sold out while product is still in the column.	Product pusher not functioning	Check to see if product pusher is engaged.
MISCELLANEOUS PROBLEMS		
Door will not close completely.	Hand assembly hitting the lower blukhead. Tri-Teq lock system is in the locked position.	Reposition y-rail stops and check y-home magnet. Open Tri-Teq lock, check for damage to lock slide.
Display shows sold out immediately upon pressing selection button of full column (sold out not clearing).	Door switch wired incorrectly or cut/pinched.	Manually press door switch. If still not vending, check wiring or replace door switch.
Vendor appears dead; no digital display and no lights.	Defective control board.	If door switch is replaced and still reading sold out, replace control board.
No digital display; vendor lights on.	Defective main harness.	If red light on control board is off, check fuse and transformer.
Vendor scrolls message on display but does not accept money.	Defective display or display harness.	Check display and display harness. Replace if necessary.
Vendor scrolls message on display but does not accept money.	Check for a flashing red light on control board.	If no light, replace control board.
Vendor accepts money but does not display credit.	Changer out of tune.	See "Tuning Changer".
Vendor accepts money but does not display credit.	Defective changer.	Replace changer.
Vendor accepts money but does not display credit.	Defective controller board.	Replace control board.
Vendor accepts money but does not display credit.	Defective changer.	Replace changer.
Vendor accepts money but does not display credit.	Defective controller board.	Replace board.

ERROR	PROBABLE CAUSE	CORRECTIVE ACTION
Vendor accepts and credits money but does not vend (does not indicate a sold-out).	Defective selection switch. Defective selection switch harness. Defective controller board.	Replace switch. Repair or replace harness. Replace board.
REFRIGERATION		
Refrigeration unit will not run.	Defective temperature sensor.	1. Check connection. 2. Replace temperature sensor.
Refrigeration unit will not run at all.	Defective control board.	Replace board.
Unit will only run in the compressor relay test mode. (Located under Test Mode)	No power to vendor. Defective cabinet switch. Defective temperature sensor.	Check power supply, also check service cord connections. Open and close the door to make sure lights and fan come on. If not, then check the cabinet switch. Follow the same steps detailed above about the temperature sensor.
Unit will not run in the compressor relay test mode. **NOTE: Leave the compressor relay test mode on, in order to check for voltage.	Wait the 3 minute delay once the cabinet door is closed. Defective control board. Defective control board.	Wait to see if unit comes on. If unit still does not come on, then replace the control board. Unplug unit at power distribution panel. Remove air dam. Reconnect power. Enable compressor relay through Test Mode. Check 2-pin connection on power distribution for 110V.
Refrigeration unit runs constantly.	Defective relay. Defective cabinet switch.	Upon opening the cabinet door, the lights and fans should shut off. If they don't, replace the cabinet switch. Upon opening the door, the display should read either errors, summary sales, or none. If it does not, then replace the cabinet switch.
Compressor will not start.	Defective control board. Defective relay - contacts are welded together.	Replace control board. Replace relay.
Compressor will not start, condenser fan motor running - unit hot (power to compressor).	Overload protector inoperative. Defective cabinet switch. Defective over load relay Compressor motor rocked Defective capacitor Defective PTC relay	Check overload (apply insulated jumper across terminal, if compressor starts, replace overload). Check for error codes. Replace cabinet switch. Replace the over load relay. Replace the refer unit. Replace the capacitor. Replace the PTC relay.
Compressor starts but does not run.	Loss of refrigerant Smashed tubings and capillary Defective over load relay	Replace the refrigeration unit. Replace the refrigeration unit. Replace the over load relay.

ERROR	PROBABLE CAUSE	CORRECTIVE ACTION
Compressor runs but cabinet temperature warm.	Loss of refrigerant Smashed tubings Defective drainage Defective temperature sensor Poor air flow Defective control board Defective door seal Defective heat exchange on condenser/ Blocking air flow by dust, lint or fins damage	Replace the refrigeration unit. Replace the refrigeration unit. Make sure the drain hose is not kinked or clogged. Replace the temperature sensor. Make sure nothing is sitting in front of the evaporator. Replace the control board. Make sure the vend flap and gasket are not open. Clean the surface of the condenser fins or straighten the bent fins.
Both compressor and condenser fan motors will not operate.	Bad refrigeration control relay.	Test relay using relay test function of the electronic controller. Replace relay if necessary.
Evaporator frosted over.	Bad connection at power board. Loss of refrigerant Smashed tubings Defective drainage Defective temperature sensor Defective control board Poor sealing Temperature setting too low. Defective temperature sensor Defective control board Fan blade hitting shroud or transformation or loose fitting From the inside of fan motor or loose fitting From the inside of compressor or loose fitting	Check wiring connections. Make corrections if necessary. Replace the refrigeration unit. Replace the refer unit. Make sure the drain hose is not kinked or clogged. Re-install hose correctly if kinked or clogged. Replace the temperature sensor. Replace the board. Check gasket, vend flap, and permagum on the bulkhead. Adjust set point in control board. Replace the temperature sensor. Replace the control board. Replace the fan blade or re-install correctly. Re-install or replace the motor. Replace the refrigeration unit.



NOTES