

AP Product
Manual

AUTOMATIC  PRODUCTS
A Crane Co. Company



P R E M I E R[®]

965 CONTROL MODULE
960 À LA CARTE MERCHANDISER

SET-UP and INSTALLATION

OPERATING SYSTEM

TROUBLESHOOTING

PARTS

PLEASE

**DO NOT REMOVE
MANUAL FROM
MACHINE**

Automatic Products ♦ 165 Bridgepoint Drive. ♦ South St. Paul MN 55075

TABLE OF CONTENTS

Warranty.....	ii
Introduction.....	iii
Features	iv
Installation	1.01
Cautions	1.01
Installation Instructions.....	1.02
Set Up Steps	1.03
Optional Equipment.....	2.01
Components.....	3.01
Power Supply	3.01
Selection Keypad & Fast Track Keypad.....	3.02
Coin Mechs, Validators and Card Readers.....	3.02
Temperature Monitoring.....	3.03
Logic Control Board & Food Driver Board.....	3.06
Operating System.....	4.01
Power Up State	4.01
Motor Scan	4.01
Standby	4.01
Keypad Echo	4.01
Credit Accumulation	4.01
Vend Process.....	4.02
Change Payback	4.02
Use Correct Change.....	4.02
Token Vends	4.02
Accountability Information	4.02
Shutdowns.....	4.02
DEX/UCS	4.02
Programming.....	5.01
Service Modes.....	5.03
Parts.....	6.01
Service/Trouble Shooting.....	7.01

To achieve the most trouble-free operation from your 960 Á LA CARTE Merchandiser, it is highly recommended that this service manual be thoroughly read and the instructions followed pertaining to installation, servicing and maintaining of the unit.

Should you have questions pertaining to this manual or the vendor, please contact your AP distributor or write directly to:

Product Support Group
Automatic Products
165 Bridgepoint Drive
South St. Paul, MN. 55075 USA
651-288-2975
651-288-2971 (fax)
© **2008 Automatic Products**

LIMITED EXPRESS WARRANTY

Automatic Products (AP) warrants these automatic merchandisers (the "Unit"), manufactured by it, to be free under normal use and service from defects in material or workmanship for a period of two (2) years from the date of delivery of this Unit to the original purchaser who purchased the Unit either directly from AP or from an authorized AP dealer or distributor ("AP Dealer/Distributor"). This warranty extends only to the original purchaser of the Unit, but only if purchased either directly from AP or from an authorized AP Dealer/Distributor ("Original Purchaser"), and is limited to the repair or replacement, at AP's sole option, of any part or parts of the Unit that are returned to AP or to the authorized AP Dealer/Distributor from whom the Unit was originally purchased, with all transportation charges prepaid by Original Purchaser, and which, on AP's examination, such returned part or parts shall conclusively appear to have been defective. This warranty does not extend to:

1. Any Unit, or part thereof, that was subjected to misuse, neglect, or accident by anyone other than AP after its delivery to the Original Purchaser;
2. Any Unit, or part thereof, that was modified, altered, incorrectly wired or improperly installed by anyone other than AP or used in violation of the instructions provided by AP;
3. A Unit, or part thereof, which has been repaired or altered by anyone other than AP or an authorized AP Dealer/Distributor;
4. A Unit, or part thereof, which has had the serial number removed, defaced, or otherwise altered;
5. Any plastic or glass windows, lamps, fluorescent tubes, and water contact parts;
6. Any Unit used outdoors;
7. Any accessories used with the Unit that were manufactured by some person or entity other than AP; or
8. Any Unit repaired within the warranty period with parts other than genuine AP built or endorsed parts.

AP DISCLAIMS ALL OTHER WARRANTIES OF ANY KIND AS TO THE UNIT AND ALL WARRANTIES OF ANY KIND AS TO ANY ACCESSORIES. THIS DISCLAIMER OF WARRANTIES INCLUDES (1) ANY EXPRESS WARRANTIES OTHER THAN THE LIMITED WARRANTY PROVIDED ABOVE AS TO THE UNIT AND (2) ALL IMPLIED WARRANTIES OF MERCHANTABILITY AND FITNESS FOR A PARTICULAR PURPOSE AS TO THE UNIT AND ANY ACCESSORIES. UNDER NO CIRCUMSTANCES SHALL AP BE RESPONSIBLE FOR ANY INCIDENTAL, CONSEQUENTIAL OR SPECIAL DAMAGES, LOSSES OR EXPENSES (INCLUDING BUT NOT LIMITED TO LOST PROFITS, LOST SALES, INJURY TO PERSON OR PROPERTY) ARISING FROM OR IN CONNECTION WITH THE USE OF, OR THE INABILITY TO USE, THE UNIT FOR ANY PURPOSE WHATSOEVER REGARDLESS OF THE LEGAL THEORY (CONTRACT, TORT OR OTHER). IN NO EVENT WILL API BE OBLIGATED TO PAY DAMAGES FOR ANY AMOUNT EXCEEDING THE PRICE PAID FOR THE UNIT. No representative of AP or any other person is authorized to assume for AP, or agree to on the behalf of AP, any other liability or warranty in connection with the sale of this Unit.

AP reserves the right to make any changes or improvements in its products without notice and without obligation, and without being required to make corresponding changes or improvements in Units theretofore manufactured or sold.

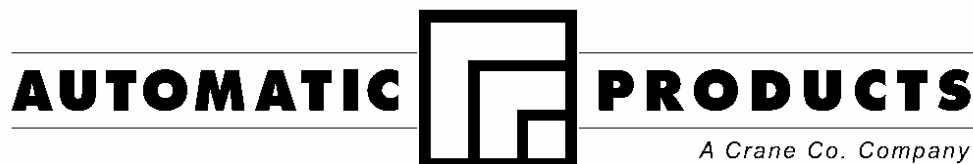

165 Bridgepoint Drive
South St. Paul, MN. 55075 USA
651-288-2975
651-288-2971 (fax)

INTRODUCTION

The 960 Á LA CARTE features simple operation and built in flexibility, as well as extensive diagnostics and error reporting facilities to provide ease of maintenance.

HOW TO USE THIS MANUAL

This manual is divided into seven basic parts:

1. Unpacking and Installation.
2. Optional Equipment
3. Components and Refrigeration.
4. Operating System.
5. Programming
6. Parts
7. Troubleshooting.



CAUTION: Certain procedures in both the operating section and the service section require that voltage be on in the machine. Only, trained personnel should perform this function. Exercise extreme caution while performing these procedures. These procedures will be marked with the lightening bolt symbol as it appears at left.



CAUTION: Certain procedures in both the operating section and the service section require a qualified trained technician to perform the particular task at hand. These procedures will be marked with the exclamation symbol as it appears at left.

Features

FEATURES OF THE 960/965 Á LA CARTE STANDARD FEATURES

- Multi drop buss capabilities (MDB).
- Extensive diagnostics capabilities.
- Friendly text-based interface.
- Dex/UCS compatible.
- Real time clock.
- Machine reset capability.
- Chime.

PRICING

- Global pricing by machine or by shelf.
- Extensive accountability, including all discounts and free vends.
- Shutdown capabilities
- Combo vends.
- Programmable spiral count.
- Upload and download capabilities for pricing and set up.
- Programmable maximum payout.

SCROLLING DISPLAY

- User friendly two-line scrolling display to help with the selection process and provide customer feedback.
- User programmable point of sale and operational messages.
- 2 line display with 20 characters on each line.

NOISE LEVEL

Operates at less than 70 db (A).

ACCEPTABLE AMBIENT OPERATING TEMPERATURE RANGE.

All equipment manufactured by Automatic Products is designed to work properly in a temperature range of 10°C to 38°C (50°F to 100°F) in still air (75% R.H. non-condensing). The machine is being stored in a temperature range of -18°C to 68°C (0°F to 155°F).

Specifications	965 Domestic	965 Export	960 Domestic	960 Export
Height	72" / 183 cm	72" / 183 cm	72" / 183 cm	72" / 183 cm
Width	10.25" / 26 cm	10.25" / 26 cm	37" / 94 cm	37" / 94 cm
Depth	33.33" / 84 cm	33.33" / 84 cm	33.33" / 84 cm	33.33" / 84 cm
Floor Space	2.37 Sq. Ft./ .22 Sq Meter	2.37 Sq. Ft./ .22 Sq Meter	8.56 Sq. Ft./ .78 Sq Meter	8.56 Sq. Ft./ .78 Sq Meter
Container Size				
Voltage (AC)	120V	230V	120V	230V
Hertz	60Hz	50Hz	60Hz	50Hz
Standby Amperes	0.7A	.35A	1.7A	.8A
Running Amperes	1A	.5A	16A	8A
Watts	120W	1440W	1920W	1840W
Refrigerant Type	N/A	N/A	404A	404A
Refrigerant Charge	N/A	N/A	23oz / 0.25 Kg	23oz / 0.25 Kg
High Side Test Pressure	N/A	N/A	440 psi	440 psi
Low Side Test Pressure	N/A	N/A	162 psi	162 psi
Shipping Weight	190 lbs / 86 kg	190 lbs / 86 kg	800 lbs / 363 kg	800 lbs / 363 kg

Unpacking

The AP 960 Series is assembled and packed so that a minimum amount of time is necessary for preparation to install it on location. The following steps are recommended to insure correct unpacking.

1. **Shipping Damage:** Thoroughly inspect the exterior of the carton for damage which may have occurred during shipment. Report any damage to delivering carrier and follow their instructions.
2. Remove the remainder of the packing material. On machines with the lock in place, the keys are taped either inside the delivery bin or inside the coin return.

NOTE: Because the weight concentration is toward the back of the cabinet, trucking and lifting should be done from the back. CAUTION should be taken when trucking from the side.

3. On machines with lock in place, unlock and turn handle to open door. When no lock is furnished, remove tape and turn handle. Swing door to its full open position.
4. Remove all packing tape and paper from various areas of machine and the shipping strap.
5. **Warranty:** The warranty card should be filled out in full and mailed at once to insure coverage.

◆ **IMPORTANT:** A set of anchoring brackets are sent with each machine. The kit is located in the bottom of the machine complete with instructions. It is recommended that this kit be installed to prevent shifting of the machine.

6. **Air Deflector:** Remove the air deflector from the delivery bin. Loosen the four screws holding the screen on the back of the machine, place the slotted holes in the air deflector over the screws and push down, re-tighten the screws.

CLEANING & MAINTENANCE

The 960 Series merchandiser will do the best merchandising job for you if it is kept clean. The amount of cleaning your machine will require will vary from location to location depending on the environment. We suggest that a thorough cleaning be performed at least twice a year in a clean environment, in addition to this, light cleaning that should be performed each service. The display windows can be cleaned with any good glass cleaner. The exterior and interior surfaces should be cleaned with warm water and mild detergent (food grade). Rinse thoroughly and dry all surfaces. Always use a clean lintless disposable towel for cleaning. There is an option in the software to perform a manual defrost (see the operating system section of this manual for instructions).

The main product shelves can be best cleaned with the spirals and product spacers removed. Refer to page 1.03 for removal of spirals and removal of the product spacers.

Clean the acceptor on the changer frequently as accumulated dirt in this area can cause coins to hang or not be accepted. Follow recommended cleaning procedures as described by the manufacturer.

- ◆ It is extremely important that the air intake screen for the refrigeration unit is cleaned weekly and that no product is stored in this machine blocking this screen or the condenser unit. This screen is located toward the front and center of the machine floor.

Installation

Cautions

The following cautionary information should be reviewed before the machine is installed. Following these requirements and warnings are required.



CAUTION: This machine is designed for indoor usage only. Any other usage will void the Manufacturers Warranty.



Voltage and Polarity Check

It is important that this machine is hooked up to the proper voltage and polarity for your country. Use a voltmeter to verify voltage and polarity **before** connecting the machine to a wall outlet. For machines located in North America, use the diagram on the next page to verify correct voltages.



CAUTION: Any procedure marked with the symbol at left requires that the Machine have the power applied and a shock hazard exists.



CAUTION: It is important that this machine is hooked up to the proper voltage and polarity for your country. Use a Voltmeter to verify voltage and polarity. Should the reading be any different than a normal reading or if you are unsure of what the reading should be contact an electrician.



CAUTION: Different countries may have unique plug arrangements. Ensure that the machine is properly grounded before operating.



CAUTION: The power cord for all machines manufactured for use outside of North America are of a type Y attachment. If the power cord is damaged, it must be replaced by the manufacturer, its service agent, or a similarly qualified person in order to avoid a hazard.



CAUTION: The machine is a heavy item. Ensure that sufficient personnel are available for lifting and transporting the machine. Use proper lifting procedures and equipment.



CAUTION: The system components in this machine utilize static sensitive components. Precautions for handling sensitive devices should be observed when handling these items.

Installation

Leveling the Machine on location is important for the machine to function properly. The four leveling screws in the legs are the means of leveling the machine. After positioning the machine, level machine in front to rear and right to left directions. After leveling, turn front right (lock side) leveling screw in about one-half turn to drop this corner slightly to make the door easier to close and lock.

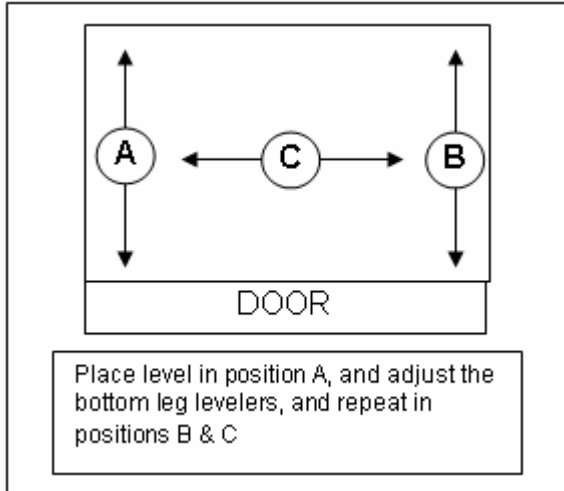

CAUTION: The following procedure requires that the machine have power applied and a potential electrical shock

Voltage and Polarity Check (for Machines located in North America Only) It is important that this machine is hooked up to the proper voltage and polarity. Using a voltmeter, perform the following checks from the illustration below. Should the readings be different from below, have a certified electrician correct the problem.

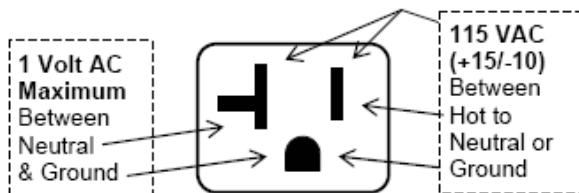

◆ **Note:** It is imperative that the machine is on its own 20 AMPERE SERVICE. Only the Control module may be plugged in to the same service.



For Health reasons it should be noted that cold (refrigerated) or frozen vending machines are designed for short term storage of already refrigerated or frozen product. The definitions for cold and frozen machines are as follows:

1. Cold is defined as 41 °F (5 °C) or lower for cold food. All food in a Refrigerated machine must have a product expiration date on the package. See your product supplier for specifics on date codes and expiration dates.
2. Slack is defined as a frozen machine set below 15 °F (-9 °C) or lower for slacking precooked frozen food.
3. Frozen is defined as 0 °F (-18 °C) or lower for frozen food. Items used in a frozen machine should have frozen designated packaging.

When installing a machine, the machine should be allowed to pull down to operating temperature before loading product into the machine, approximately 1 hour for a cold machine and 2 hours for a frozen machine. See page 4.19 for instructions on setting temperature.

For more information of pull down times and health control see page 3.03 of the components section of this manual.

Installation

Basic Set Up Steps

1. Remove all packing materials.
2. Set prices and options on control board.
3. Set Clock.
4. Add coins to coin mechanism.
5. Coin test.
6. Bill test if applicable.
7. Install lock cylinder if needed.

Loading Shelves

Open door to full open position, push down on the plastic lock lever on the right side panel by shelf to unlock shelf, holding lever down. Grasp the shelf, under both front corners, lift the front of the shelf slightly and pull forward until the shelf reaches its stop. The shelves tilt down (do not drop) to make loading easier. Only one product shelf should be in the loading position at a time. When returning a shelf, be sure the shelf is in its full home or vend position. Begin loading with the top shelf. Move it to the loading position. The height spacing for items is greatest in this shelf and the tallest items should be placed there. Soft items should be placed in the lowest shelf, making the drop distance as short as possible.

IMPORTANT: Product must not be forced into the spiral spaces but should fit freely. If the product is too tight, use a larger pitch spiral. The bottom of the product should be placed on top of the spiral that rests on the shelf surface.

Vending Large Products

The 960 Series can be configured to use two spirals to vend one product. The motor to be paired will be called the left motor, and must be an even numbered motor. Any even numbered motor may be paired. This motor must always be paired to the odd numbered motor next in sequence (i.e. motor "110" will always be paired with motor "111" and "114" always with "115"). Only motors in the same row of the machine can be paired. For more information on motor pairs see the operating system section of this manual.

Adjusting the Stopping Position of the Spiral

One primary difference that distinguishes the new motors from previous motors is the presence of an eight sided star at the drive hub of the motor. This permits the stopping position of the spiral to be customized by the operator to ensure the best possible delivery of product. To change the stopping position of the spiral, remove the spiral lock from the motor by pinching the shaft of the spiral lock from the back side of the motor and pulling forward on the front side of the spiral lock. The spiral lock can be reinstalled in any of eight different positions by turning the spiral lock to the position desired and pushing the shaft of the spiral lock through the eight sided star at the drive hub of the motor.

Removal of Spiral

Grasp the front of the spiral and turn it clockwise for an even numbered selection and counterclockwise for an odd numbered selection. Lift the spiral up and off of the spiral clock. When replacing a spiral attach it around the tab on the spiral lock and turn the spiral to lock it in place. Be sure the front end of the spiral is positioned properly. The spiral lock is attached between the spiral retainer tabs. Give a light forward pull on front of the spiral to check it is locked in place.

Product Spacers

A product spacer is used to reduce the width of the product area and can be used on any shelf. Spacers should fit within 1/8" of the product but should not fit tight against the product. There are four positions in each column where these spacers can be placed. To install the spacer, lift upward on the front of the spacer, align the lock ear on the rear of the spacer with the slot on the rear of the cabinet, push the spacer downward aligning the three tabs on the lower edge of the spacer with the three sets of slots on the shelf bottom. Pull the spacer forward to lock in place.

Lock Product Shelves

After all the product has been loaded be sure all shelves are returned to their vend position behind the front roller guides.

Install Proper Price Tabs

Place the proper price tab into the price tab holder for each selection in the main product area.

Installation

Control module Installation Instructions.

- A. Remove the 3 hole plugs from the top, inside right corner of the 960 cabinet. Once removed, remove the foam insulation (pre cut) behind the holes.
- B. Locate the front and rear lower support brackets on the bottom right hand side of the 960 cabinet. (These brackets have already been installed at the factory.) There should be a 1/8" space opening between the cabinet and the mounting bracket, these mounting brackets can be adjusted by loosening the 2 outside bolts from each of the leg welds on the lock side of the cabinet.
- C. Move the base of the Control module close to the 960 cabinet so the bottom left edge of the Control module rests on the support bracket. Tip the Control module to an upright position.
- D. Install the upper mounting plate using the 1/4-20 KEP nuts provided. Install three in the refrigerated cabinet and three in the control module.
- E. Put the insulation and plugs back into the 3 holes in the refrigerated cabinet.
- F. Locate the interconnect harness (communications cable) coming out of the back of the 960 and route it into the back of the Control module securing it with a screw to the back, then route to the Logic Control and plug into the **P4** connector (MDB). When using a MDB coin mech and/or bill validator these peripherals must be plugged into the pig tail coming off of the communications cable. The machine attached to the Control module is considered Cabinet 1.
- G. Level the Control module to the machine by adjusting the leg levelers.



CAUTION: Because the Control Module is top heavy and unstable, always use two people when attaching it to the 960.

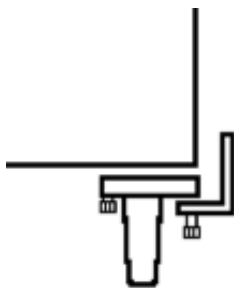

◆ **NOTE:** Disconnect the Communications Cable before moving the machines.

960/965 Series 0508

Using a Second Machine with a Control Module.

If a second machine is to be operated off of the Control module, it should be placed to the right of the Control module. The second machine is free standing and does not physically attach to the Control module. Find the interconnect harness coming out of the back of the second machine and route it into the back side of the Control module to the Logic Control board and plug the harness into the jumper coming out of the cabinet 1 interconnect harness. This machine is considered Cabinet 2. The cabinet id jumper in any 960 should be checked to verify it is properly set.

◆ **NOTE:** The second machine being run off of a Control module **MUST** have its own **20 Ampere service**; it **CANNOT** be plugged in on the same circuit as Cabinet 1.

Connecting a 960 to a 930 Series Snack

A 960 machine can also be driven off a 930 Series Snackshop® in lieu of a Control Module. To do this, locate the interconnect harness coming out of the back side of the food cabinet and route it into the back side of the snack (remove the triangular plate just above the line cord) to the Logic Control board and plug into the **P4** connector. The 960 will be considered Cabinet 2. Only one 960 can be operated off of a snack machine.

◆ **NOTE:** The 930 and 960 **CAN** be plugged into the same 20 Ampere service if necessary.



Installation

The 965 Control Module is used to host a 960 Frozen/Refrigerated machine. The following steps should be followed.

1. **Check the software version of the food driver board. For the 960/320 to work properly with a 965 Control Module the food driver board must have Revision 2.1 or greater software. Arrow A in the diagram.**
2. Set the cabinet jumper to the appropriate cabinet. Jumper B in diagram.
3. Set the refrigeration jumper to your desired setting, either frozen or refrigerated. Jumper C in diagram.
4. Plug the communications cable directly into the MDB plug on the 960 control board.
5. Set the temperature in Mode 40.
6. Set motor pairs if applicable in Mode 23.
7. Set the Golden Eye selections if applicable.
8. Set prices in Mode 20.

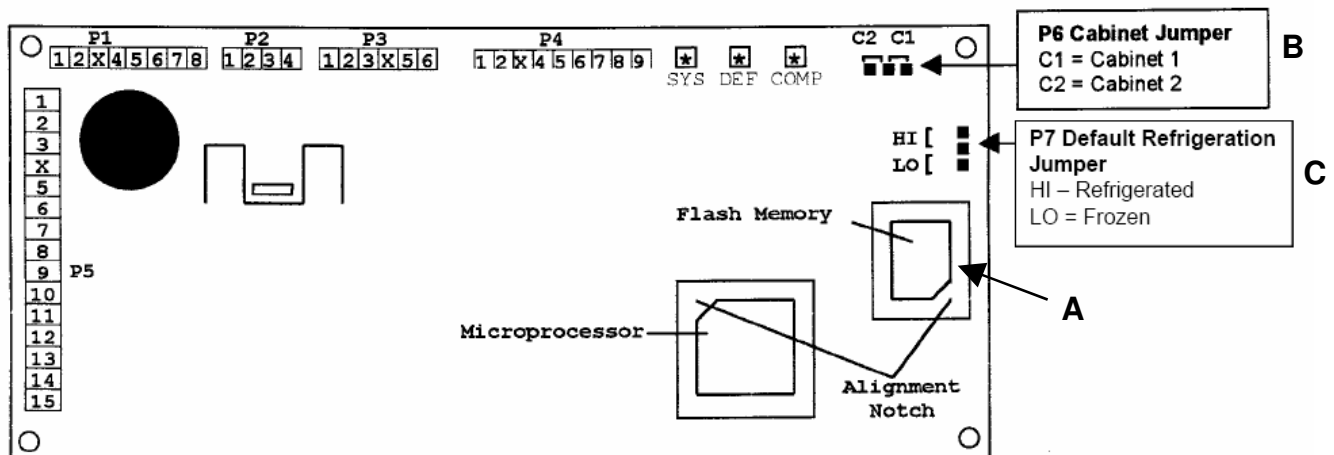

SPECIAL INFORMATION

When a new 965 Control Module is used to host a Model 960/320 \hat{A} LA CARTE merchandiser, the software on the Food Driver Board (FDB) MUST be Version 2.1 or higher. If the software is less than Version 2.1, you may experience repeated motor and baffle door errors. These errors will disable the \hat{A} LA CARTE. If you require new FDB software, please order P/N 360273.

Installation

Connecting Golden Eye from a 960 to a Host Cabinet

When using the Golden Eye Guaranteed Delivery System in a Á LA CARTE – 960/320 Food/Frozen merchandiser, the Golden Eye harness from the Communications cable must be connected to the existing Golden Eye harness in the host snack machine, or to the Golden Eye junction harness in the 965 Control Module.

1. Identify the harness in the host machine plugged to P11, located on the right edge of the board, bottom connector.
2. In a 930 Series or 6500 Series, there should be a connector plugged to the board in P11. When the host machine is a snack, there will be one small 6 pin connector available in this harness. See Photo # 1, below. The mating 6 pin connector from the 960/320 Communication cable should be connected to this extra 6 pin connector.
3. When using a 965 Tower with one or two Á LA CARTE merchandisers, the harness connected to P11 will have 2 small 6 pin connectors available – see Photo 2 below. In this configuration, the Á LA CARTE identified as Cabinet 1 should be connected to the 6 pin connector with the label on it identifying it a “Golden Eye 1” and Cabinet 2 should be connected to the other 6 pin connector.
4. Access Mode 21 and enable the required selection for Golden Eye.



Photo 1 – Á LA CARTE Golden Eye connection in a host SNACK machine

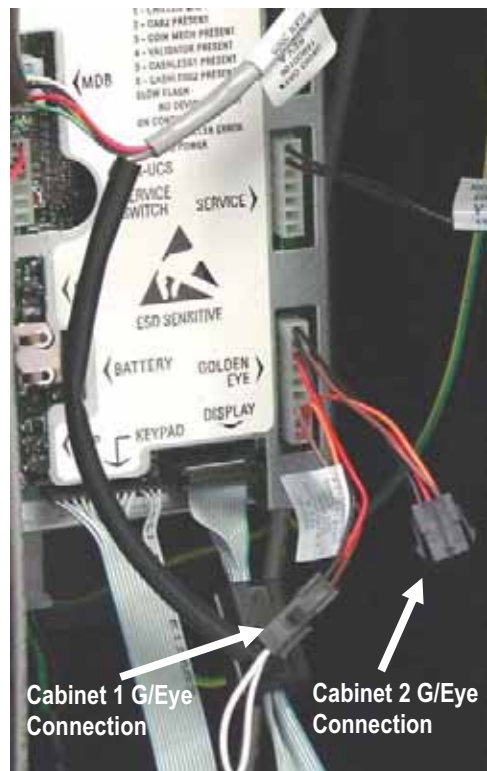

Photo 2 – Á LA CARTE Golden Eye connection in a 965 Tower using Cabinet 1

Optional Equipment

Touch Memory Harness

The touch memory harness (Part # 16800013) is used in conjunction with the touch memory button (CHIP) available separately (Part # 17500003). This harness will allow you to download all settable data, with the exception of the time and date. Once CHIP is programmed you can take it to as many machines as you wish to upload the information stored in CHIP. CHIP can be programmed from a machine that is already set up and then used to set up other machines that are to be programmed identically. For more information see Mode 30.

DEX/UCS Harness

A chassis mount DEX harness (Part # 16800044) is available. This harness allows you to download the DEX information.

Components

Power Supply

The 120 VAC power cord from the wall outlet enters the machine and plugs into the bottom of the main junction box. The junction box contains the power distribution components, consisting of the control board, filter, circuit breakers and the transformer. The voltage outputs from the junction box to the board are 24 volts and 8 volts and plugs into the (P3 position) of the Logic Board.

Lighting System

There are two fluorescent lamps in the AP 960 Series machines. The lamps are located vertically on the inside of the door along the edge of the outer glass which light up the main product area. The starter is located on the underside of the bottom lamp socket of each lamp. Each lamp is covered by a plastic shield.

Heated Glass

The glass on the inner door is a double pane, heated thermal pane. There is a connector on the bottom right hand side of the glass. The glass receives power for the heater strip through this connector from the junction box.

Main Product Shelves

There are a maximum of five main product shelves per machine. Each selection has its own motor mounted to the back of the shelf. Every shelf has its own harness and plug for connecting to the remainder of the circuit through the cabinet receptacle, located in the rear right of the cabinet. You also have the capability to adjust each shelf 1/2" either up or down on any shelf. To do this the shelf should be removed and the cabinet back harness receptacle lowered or raised with the right & left shelf tracks.

◆ **Note:** When exchanging the shelves, you will not need any parts but you will have to reprogram the machines for prices and selections.

Removal of Product Shelf

- A. Lift up and push the lock lever toward the back of the cabinet.
- B. Pull the shelf to its loading position.
- C. Grasp the shelf in front and rear center. Lift front of shelf up above horizontal and pull shelf forward while lifting.
- D. To install shelf, reverse above procedure.

Delivery Bin

This is located below the display window on the door and is mechanically operated. The linkage on the outside end of the delivery bin may require occasional lubrication. Should the door become difficult to operate, place a small amount of grease on the arm tracks.

Removal of Delivery Bin

- A. Remove the screws from the sides of the delivery bin. These screws fasten into the lower door brace and remove the two screws and brackets at the top of the delivery bin.
- B. Grasp delivery bin on both sides and lift up and pull back. Should the bin be tight, rock it by lifting on one end, then the other.

Replacement of Delivery Bin

- A. Locate lip on front edge of delivery bin over lower edge of opening in door and behind trim. Press down along lip to make sure it is fully engaged between door and trim.
- B. Install the four screws and two brackets, to secure bin to door.

Baffle Door

The baffle door is located above the delivery bin and extends out from the bottom of the main product area. The purpose of the baffle door is to seal the area between the refrigerated cabinet and the delivery bin. Each time a selection is made the baffle door is opened before the product is delivered and is closed after the product has been delivered. The baffle door is opened and closed by a motor mounted toward the back left hand side of the machine just above the compressor. The baffle door can be re-opened one time after a vend by pressing the coin return.

Components

Selection Keypad

The Selection keypad (shown at right) is located on the swing panel directly below the display. The Selection Keypad is used as an input source for settable data while in the Service Mode. The keypad is only active for service functions when the door is open, so even in the event of vandalism to the control bezel; no access to the control functions is permitted.

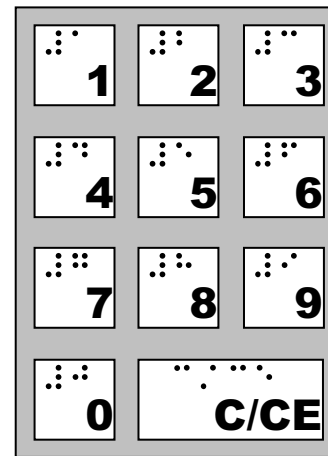

965 Selection Keypad.

Fast Track Keypad

The Fast Track Key pad (shown below) is located on the front of the swing out panel directly below the selection keypad. The Fast Track Keypad is only active when the control module door is open, so even in the event of vandalism to the control bezel; no access to the control functions is permitted. The Fast Track Keypad provides you with shortcuts into many of the service modes described elsewhere in this manual.

Note

- ◆ The “C” key on the Fast Track Keypad is a duplicate of the “C/CE” key on the numeric keypad.

Coin Mechs, Validators and Card Readers

The 965 Control Module supports MDB protocol only. The maximum number of MDB payment peripherals is one coin mechanism, one bill validator, and two card reader systems.

The 965 Control Module will automatically determine at power up which peripherals are connected and configure itself accordingly

	MDB Coin Mechanism	MDB Bill Validator
CMS	NRI A66 NRI G46	SMV2 4017 SMV2 4117 MB-2017 (recycler)
Mars	TRC-6510 TRC-6512 VN-4510 CF7512	VN2502-U5M VN2602-U5M
CoinCo	9302-GX, USQ-G701 USQ-G703 USQ-L701	BA32R BA52R MAG32 MAG52
Conlux	USLZ-004-01F CCM 5 G	USLZ-004-01F

- ◆ **Contact your coin mechanism and validator supplier for additional models.**

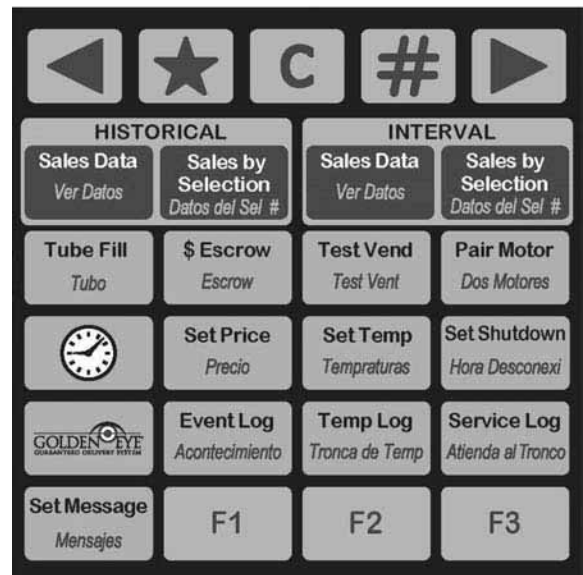

965 Fast Track Keypad.

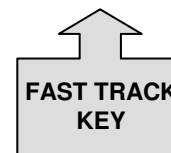

Service Modes in the Programming Section starting on page 5.01 which have Fast Track Keys assigned will have the Fast Track symbol next to them.

Components

Temperature Monitoring

To display the temperature of all food and/or frozen cabinets in an installation depress and hold the “C” (for temperatures to be displayed in Celsius) or “0” (for temperatures to be displayed in Fahrenheit) button on the front panel keypad. After three seconds, the temperatures (in all refrigerated and frozen cabinets present in the installation) will be displayed.

The Refrigeration System

The refrigeration system is comprised of a 3/4 horse compressor and is a hermetically sealed system (no service ports). The refrigerant used in the refrigeration system is 404A and the charge is 23 ounces. The compressor is turned on and off by a relay contained in the refrigerated cabinet junction box. This relay is energized by the Food Driver Board (FDB). The temperature sensor is plugged into the P2 connection of the FDB. The entire refrigeration assembly comes out in one piece by removing the two screws (to the right of the condenser) fastening the refrigeration assembly to the cabinet bottom.



CAUTION: Because of the weight of the refrigeration assembly it should be removed by two people.

Refrigeration Control

The refrigeration system in the AP 960 cabinets is controlled by the electronic control system (ECS) according to the temperature range selected by the operator while in the programming mode. The temperature readings from the temperature sensor are accurate to 1.8° F (1°C). The temperature sensor data is monitored and the readings averaged over time. The cabinet temperature is checked once every 5 seconds. Using the Set Temperature menu item, the cabinets may be designated as Ambient, Food or Frozen. When a cabinet is designated as Ambient, the Control System will not control the temperature in that cabinet and the refrigeration system in that cabinet will be disabled if it exists. Temperature readings will still be available for cabinets designated as Ambient. When a cabinet is designated as Food or Frozen, the Control System will attempt to maintain the temperature in the cabinet to within 3° F of the target temperatures specified in the Set Temperature menu item during normal operation (this is fixed at 36°F (2° C) for Food and is settable from -15°F to +10°F (-26°C to -12°C) for Frozen). To accomplish this, the refrigeration unit will be turned on when the temperature exceeds the appropriate target temperature by more than 3°F for 3 seconds during normal operation. The refrigeration unit will then remain on until the temperature falls 3° below the target temperature for 3 seconds.

Health Monitoring

The AP 930 and/or 965 Control Module allow for accurate monitoring of all refrigerated and/or frozen cabinets in the installation. This also allows for shutdown of each cabinet individually by the machine without impact to the others. When the machine shuts down a cabinet due to an out of tolerance temperature, the light in that cabinet is turned off, all selections in that cabinet disabled and the display updated to indicate “CABINET X OUT OF SERVICE” (where “X” is “1” if the temperature sensor in Cabinet 1 detected the out of tolerance condition, or “2” if the temperature sensor in Cabinet 2 detected the out of tolerance condition). A temperature sensor is present in each refrigerated and/or frozen cabinet. The pull down period describes the time elapsed between a cabinet Power Up (door closed) and the point in time when the cabinet temperature first reaches the target temperature. Health processing is suspended during the pull down period. If the pull down time period exceeds 75 minutes in a Frozen cabinet or 30 minutes in a Food cabinet however, vending will also be disabled in that cabinet for health reasons. Vending will be allowed again after the door to that cabinet has been opened and closed. The pull down period does not apply to Ambient cabinets. If at any time during normal operation after an initial pull down period, the temperature in a Frozen cabinet rises above the set target temperature by 10°F for more than 15 continuous minutes of temperature readings, vending will be prohibited in that cabinet. If at any time during normal operation after the initial power up pull down period, the temperature in a Food cabinet rises above +41°F for more than 5 continuous minutes of temperature readings, vending will be prohibited in that cabinet. The cabinet temperature control processing will remain unaffected by this vending state. An error message will be recorded indicating the health Tim-out occurred. Vending will be allowed again after the door to that cabinet has been opened and closed.

Components

Defrost Processing

The refrigeration units in the 960 cabinets are defrosted by the refrigeration control system at regularly scheduled intervals based on the defrost interval, starting from the Defrost Time selected while programming. A defrost cycle will begin with the compressor and condenser fan turned off and the defrost heater on. The heater will remain on until the Defrost Thermal switch indicates that the temperature of the air around the refrigeration coils has reached the desired temperature. The compressor will then be turned on two minutes later. Normal refrigeration processing then resumes. A defrost cycle will also

occur 75 minutes after the door is closed in a Frozen cabinet or 45 minutes after the door is closed in a Food cabinet. If the cabinet is a food cabinet and the compressor has not yet reached pull down, the defrost cycle will be delayed until it reaches pull down. Another defrost cycle will occur either 6 or 8 hours later where 6 or 8 is the number of hours specified in the defrost interval field of the Set up Defrost Menu item in the programming menu. If a scheduled defrost is to occur before 4 hours after the power up defrost is complete, it will be delayed until 4 hours after the power up defrost is complete. All subsequent scheduled defrosts will occur at their normal times.

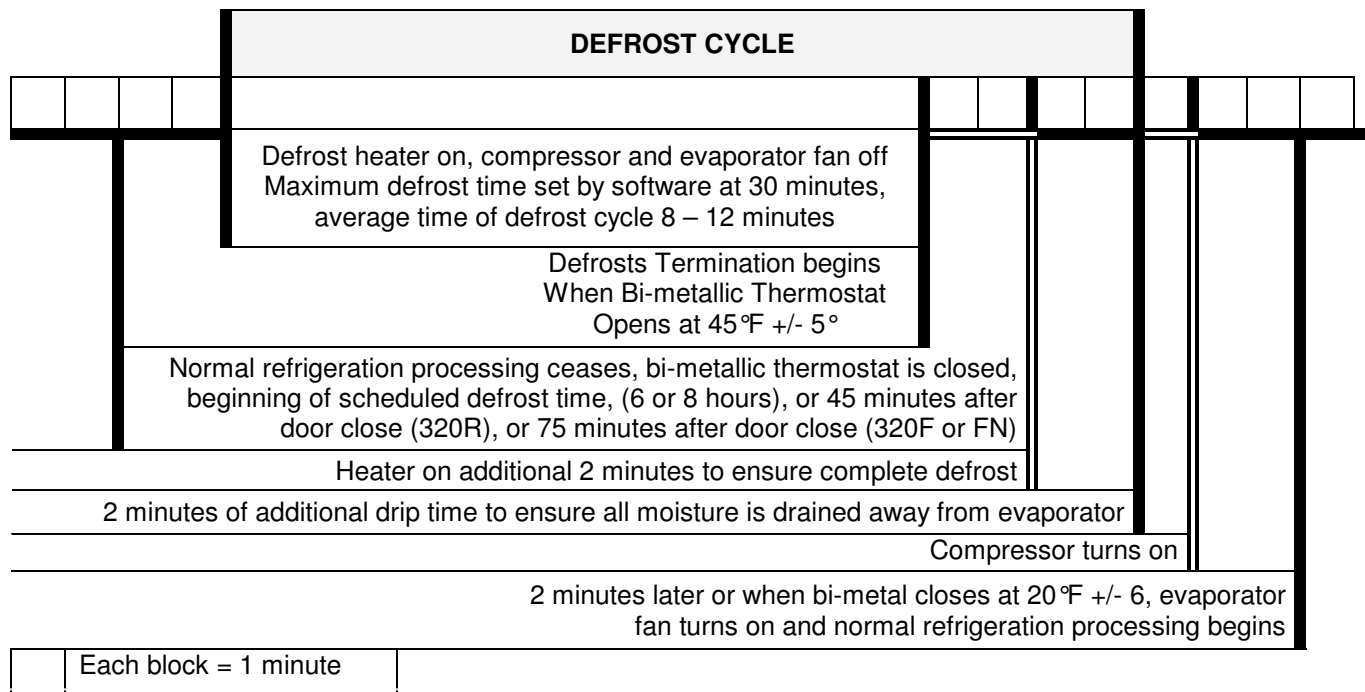

Manual Forced Defrost

Open the door and press 41 on the keypad to enter the Set Up Defrost mode, Press the # key to setup the defrost for the specific cabinet, press the * key, the compressor will turn off and a defrost cycle will begin in two minutes.

Normal Temperature Operation

With the temperature set at -15°F, the following three conditions indicate a correctly operating refrigeration unit:

1. Unit should reach that temperature within 1 hour.
2. After reaching that temperature, Compressor on cycle should not exceed 35 minutes.
3. During a defrost cycle, the cabinet temperature should not rise above 0°F.

Current Readings

Stand-by

Compressor On

Defrost Cycle

Defrost heater

Resistance

120V Operation

1.5A +/- .5

12A +/- 1A

5A +/- .5A

23 ohms +/- 3

230V Operation

.75A +/- .5A

7A +/- .5A

2.5A +/- .5A

85 ohms +/- 6

Components

Vend Motors

The vend motors used in the 960 Series machines have been specifically developed to operate with the AP Control System. One primary difference that distinguishes the new motors from previous motors is the presence of an eight sided star at the drive hub of the motor. This permits the stopping position of the spiral to be customized by the operator to ensure the best possible delivery of product. Motors are of the fast trac style, with all electronics required to correctly operate the motor contained inside the gear case or the motor housing and no external control board. Each of the motors used with the 960 Control System will have two terminals. The two terminals continue to be used to identify the shelf and column (selection) to be vended.

Each motor requires two wires to operate correctly. These wires are: shelf common, and selection.

Each selection on a shelf will have the same common shelf wire - all shelf harness use wire #12 as a shelf common. This corresponds to the selected shelf wire in the cabinet harness. The terminal for the shelf common in the harness is the smaller of the two.

Selection numbers are assigned from left to right, starting with selection 0. Each selections number corresponds to the number of the wire for that selection.

Selection numbers in the 960 Series Machines support a three digit selection system. The first digit indicates the cabinet number, the second digit is the shelf number and the third digit is the selection number on that shelf.

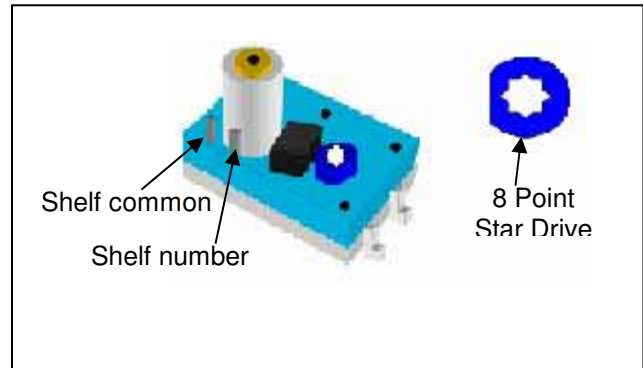
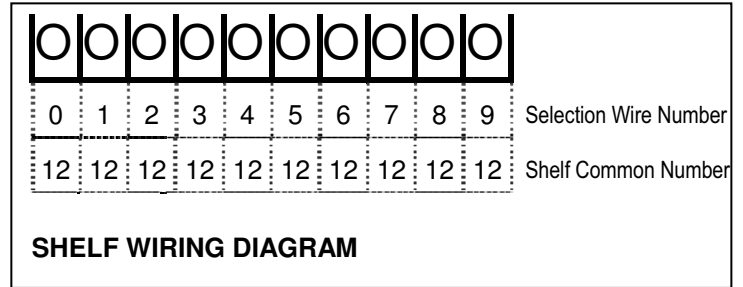

Part #	Case Color code	Description
360275	1/2 blue, 1/2 white, 8 point star drive	CW food/Snack motor
360276	1/2 blue, 1/2 grey, 8 point star drive	CCW Food/Snack motor

960 Series Motors.

Components

Control System and Boards

The Control System consists of up to three different boards, depending on the configuration. All Model 930 and all Control Modules consist of the Logic Control board (LCB) and the display board. All 960 machines also contain a Food Driver Board (FDB).

Logic Control Board (LCB) & Display

The LCB interfaces with the FDB, display board, selector panel, FastTrack keypad, coin Mechs, bill validators and all other peripherals. The LCB also stores all the programming and MIS information. In addition the LCB supplies power to the FDB. The 965 Control Modules display contains a 2 line, 20 character display capable of pre-programmed graphic messages. All Credit, Price, Diagnostic Information and Options (In Service Mode) will be displayed on this display.

Food Driver Board (FDB)

This board contains all the temperature monitoring functions for the cabinet that it is contained in, and communicates with the LCB via a 6 wire computer level interconnect harness. The FDB has three LEDs on it and the status of the FDB can be determined by observing these LEDs. The three LEDs will give you the status of the communications between the FDB and LCB, if the board is currently telling the refrigeration unit to run and if the board is currently telling the machine to go through a defrost cycle.

The Food Driver Board is located on the front face of the Relay Box for the compressor assembly. This board controls the function of all the refrigeration components along with providing the circuits for the vend motors and the baffle delivery door. There are also two jumpers for default settings of this board.

These jumpers are a set of three pins which will have only two pins connected at any one time. The connection between the two pins is made by a small black cap, which slides over the two pins in use. The black caps are identical, and should not be removed from the board for any reason. The two jumpers are the Cabinet selection jumper and the temperature control jumper.

Cabinet Selection Jumper

The position of this jumper identifies which cabinet is named CAB1 (Cabinet 1) or CAB2 (cabinet 2). These are abbreviated on the FDB board cover decal (pictured below) as **C1** and **C2**. Cabinet 1 will contain the selections 110 through 157 and Cabinet 2 will contain the selections 210 through 257. All machines are shipped with this jumper installed on CAB1. This jumper should be changed only if you are connection a second cabinet to a 965 Control Module or a 930 snack.

Temperature Control Jumper

The second jumper on the board controls the default setting for the temperature in the event the FDB loses communication with the LCB. This will hold the cabinet temperature at the setting indicated by the jumper. A jumper set at **"R"** will hold the temperature at 36°F (2°C), and a jumper set at **"F"** will hold the temperature at -15° (-26°C). If you change the temperature in the Set Temperature mode, you must also change the position of the jumper to the corresponding position. The position of this jumper can be verified through the hole in the board cover.

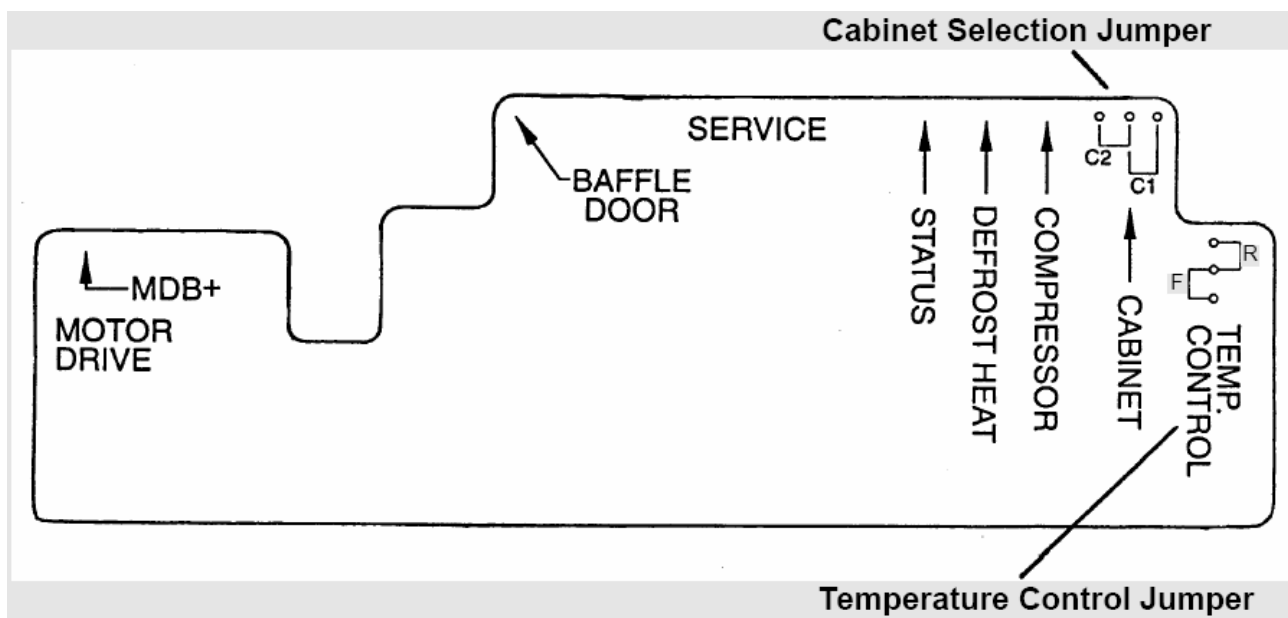

Operating System

Power Up State

Following a power-up or reset condition, the display will scroll "AUTOMATIC PRODUCTS" followed by a flashing "GPL / CMS".

Motor Scan

Upon closing the door the display will show the firmware revision level (see Figure 11), perform a diagnostic routine that will scan and home the motors determining what motors exist in the configuration. After completion of this scan, the status of all the motors will be reported on the display (see Figure 12).

Standby

In Standby, the operator selected message will appear on both the top and bottom line. The factory default messages are "Have a nice day" on the top line, and "Credit .00" on the second line. See the Operating system, Mode 60 for details on how to change the standby message. As soon as credit is deposited, the accumulated credit will be shown on the bottom line until a selection is made.

Keypad Echo

When the first numeric key is pressed the display will show the selection number in the third leftmost digit. This character will remain for 5 seconds or until another key is pressed. Once all 3 keys are pressed, the selection will be shown on the display for one second and then the associated price for the product will display. If the selection is disabled or shut down (using the Shutdown pins) the display will show "Invalid selection" for 5 seconds or until a new selection key is pressed. If the selection is enabled but not functioning properly (not present or not home) the display will show "Make Another Selection" for 5 seconds or until a new selection key is pressed.

Credit Accumulation

Credit may be accumulated through a coin changer, bill acceptor or card reader. Non revaluing card reader credit cannot be mixed with coin and/or bill credit during a single transaction or vend. If card reader revalues the coin & bill credit goes to the card, and then a vend may still be attempted. Credit acceptance will be disabled when the accumulated credit equals or exceeds the highest priced item. Credit accumulation from any source is disabled or escrowed if change is not available. If the amount of card reader credit available exceeds the maximum displayable credit, the maximum credit will be displayed.

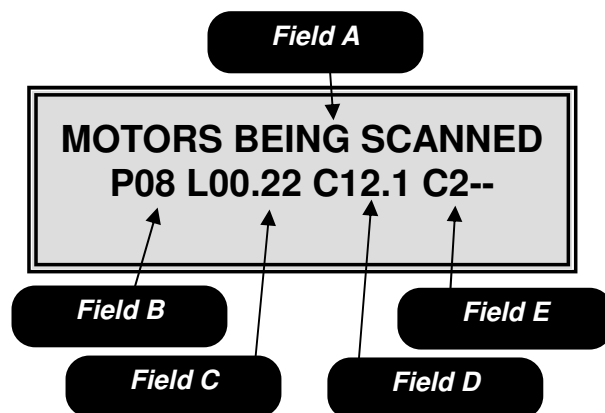

FIGURE 11

Field A is the informational heading.
Field B is the microprocessor version number.
Field C is the software version number.
Field D is the software version in the temperature control board for cabinet 1.
Field E is the software version in the temperature control board for cabinet 2.

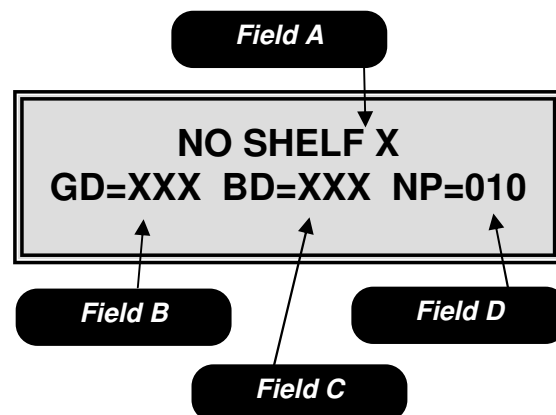

FIGURE 12

Field A shows the lowest shelf number not found during the automatic scan of motors.
Field B is the number of good motors.
Field C is the number of bad motors.
Field D is the number of motors not present.

Operating System

Vend Process

After a keypad entry is made the logic board determines if sufficient credit is available for the selection attempted. If the credit is greater than or equal to the selection price, a vend attempt will be made for that selection. During this time, the selection will be shown on the display. If credit is less than the selection price, the correct price and current credit amount will be displayed for 5 seconds or until a new selection key is pressed.

Change Payment

Change will be returned during the vend process as soon as it is determined that the motor has moved off of the home position. This will change if Golden Eye is active. When Golden Eye is active, the transaction is not completed until the GE sensors confirm delivery of the product. The amount of change to be returned will be displayed until all coinage is paid back. The least amount of coins available will be paid back for all credit returns.

Use Correct Change

If the level of the changer's least value coin tube is below the lowest sensor, the "Use Correct Change" message will be shown on the display. If the machine is unable to vend the selected item because of low change, the display will show "Use Correct Change" for 5 seconds or until a new selection key is pressed.

Make Another Selection

If the machine is unable to vend the selected item, the "Make Another Selection" message will be displayed for 5 seconds or until a new selection key is pressed.

Token Vends

Following the acceptance of a token, the display will show "FREE". Further credit acceptance is disabled and a single item may be selected to vend for the token credit. See the Operating Section Mode 29, for instructions on setting up and choosing which selections will work with tokens.

Accountability Information

All MIS data is stored as both resettable and non-resettable with the exception of Machine Identification Number, Machine Serial Number, Software Version Number, Number of MIS Resets, Number of Machine Resets and Door Open History, which are stored as non-resettable only. All vend counters will roll over at 7 digits (9,999,999). All cash counters will roll over at 8 digits including the decimal point (999,999.99). Vend accounting (MIS) is updated as shown in Table 1.

Field	Vend Type			
	Token	Vend	Testvend	Freevend
#VENDS	X	X		
\$VENDS (Sale Price)	0	X		
#/PROD	X	X		
\$/PROD (Sale Price)	0	X		
#/TESTVEND			X	
#/FREE				X
\$/FREE				X
#/TOKEN	X			
\$/TOKEN	X			

Table 1: MIS Field Update Chart

X - Indicates which field is updated for a given vend type.

Shutdowns

There are 2 options available to shutdown the 965 Control Module.

1. The 965 Control Module is capable of having timed shut down periods. More information can be found in the programming section Mode 51.
2. The control board on the 965 Control Module can be shutdown by creating a closed circuit between pin 3 & pin 4 on the service connector P2. This shutdown type will lock out selections entered into Mode 32. When in this shutdown type and a shutdown selection is entered the display will show "Invalid Selection" for 5 seconds or until a new selection key is pressed.



Caution: Do not apply Voltage to these pins! Damage to the Board will result!

DEX/UCS

The 965 Control Module supports DEX/UCS Communications Protocol - NAMA Vending Industry Data Retrieval Standard. The machine will automatically recognize the DEX/UCS device when it is plugged into the control board and will recognize when the device initiates the communication protocol. The transmission/reception of data to the device will then take place automatically. See the next page of this manual for definitions of the DEX/UCS download protocol.

◆ See Page 5.32 for information regarding the setting of a Serial Number, Machine id and Location id.

Operating System

The MIS data stored by the machine for a DEX/UCS download is as follows:

DEX/UCS Output	Definition
ID1*API74563219087456123*STXXX*0010*98765432198765432**12345678901234567	Machine S/N*Machine Model*Machine Revision*Location ID**Machine ID #
ID4*2*1*0	# of positions to right of decimal pt*Country (ITCC)*Currency in use
ID5*050510*122708	System Date -YYMMDD*Time - HHMM
ID7***APi	***Manufacturer Code
CB1*API33221144556699887*ST/130*0001	Control Board Serial Number*Model*Software revision
VA1*1200*18*300*5*0*18*0*5	Total Sales Historical Amount*Total Vends Historical Count*Total Interval Sale Amount*Total Interval Vends*Historical Value of All Discounted Paid Vends*Historical count of All Discounted Paid Vends*Interval Value of All Discounted Paid Vends*Interval Count of All Discounted Paid Vends
VA2*0*2*0*0	Historic Value Test Vends*Historic Test Vends*Interval Value Test Vends*Interval Test Vends
VA3*0*0*0*0	Value -Free Vends Historical*Count -Free Vends Historical*Value -Free Vends Interval*Count -Free Vends Interval
TA2*0*0*0*0	Value -Token Vends Historical*Count -Token Vends Historical*Value -Token Vends Interval*Count -Token Vends Interval
CA1*0*0*0	Serial Number*Model*Software revision
CA2*1200*18*300*5	Total Cash Historical*Total Cash Vends Historical*Interval Cash*Interval Vends
CA3*350*0*150*2*1350*0*850*5*200*500	Interval cash received*Interval Cash to Cashbox*Interval Cash to tubes*Interval Value of Bills*Historical Cash received*Historical Cash to Cashbox*Historical Cash to Tubes*Historical Value of Bills*Interval Value of Bills
CA4*50*0*1150*1100	Interval cash dispensed*Interval cash dispensed manually*Historical cash dispensed*Historical cash dispensed manually
CA7*0*0*5*18	Interval Value cash discounts given*Historical Value cash discounts given*Interval Number cash discounts given*Historic Number cash discounts given
CA9*0*0	Value of Vends while in exact change-interval*Value of Vends while in exact change-historical
CA10*0*0	Value of all cash added since last reset*Value of all cash added since initialization
CA15*1225	Value of coin tubes
BA1*29821563422*SPRINTR*504	Bill Validator Serial Number*Model*Software revision
DA1*0*0*0	Cashless 1 Serial Number*Model*Software revision
DA2*0*0*0*0	Cashless 1 Historical Vends*Historical Cash*Interval Vends*Interval Cash
DA4*0*0	Historical Value credited to Cashless 1*Interval Value credited to Cashless 1
PA1*CAN	Can Sales Header
PA2*4294919762*550	Historical Vends-Cans*Historical Cash-Cans
PA1*110*50*110*0 (See Note 1)	Selection ID*Vend price*Product code*Spiral Count
PA2*0*0*0*0 (See Note 1)	Historical Vends Selection 110*Historical Cash Selection 110*Interval Vends Selection 110*Interval Sales Selection 110
PA4*0 (See Note 1)	Historical Free Vends Selection 010
PA5*050510*122708 (See Note 1)	Date & Time of last vend for this selection
EA1*EGS*000000*000008*00	EGS(Door Opening History)*Date YYMMDD*Time HHMM*Duration (minutes)
EA2*EGS*1*4**1	EGS*Interval Door Openings*Historical Door Openings*Current Status 1 = Door open
EA1*EJB*000000*000008*00	EJB (Motor Errors)*Date YYMMDD*Time HHMM*Duration (minutes)
EA2*EJB*60*194**1	EJB*Interval Motor Errors*Historical Motor Errors**Current Status 1 = Motor Error exists
EA1*ELA*000000*000008*00	ELA (Product Delivery Errors)*Date YYMMDD*Time HHMM*Duration (minutes)
EA2*ELA*0*0**0	ELA*Interval Product Delivery Errors*Historical Product Delivery Errors**Current Status 1 = Detector OK
EA1*EJH*000000*000008*00	EJH (Health Code Errors)*DateYYMMDD*Time HHMM**Duration (minutes)
EA2*EJH*0*0	EJH*Interval Health Code Errors*Historical Health Code Errors**Current Status 1 = Detector OK
EA1*OA1E*000000*000008*00	OA1E (Date & Time Resets)*Date YYMMDD*Time HHMM**Duration (minutes)
EA2*OA1E*0*0	OA1E*Interval Date & Time Resets*Historical Date & Time Resets**Current Status Always = 0
EA3*2*****2*2	Number Of Reads With Reset Since Initialization*****Number Of Reads Since Initialization*Number of Resets since Initialization
EA4*000000*000008	(Initialization Timestamp)YYMMDD*Hums
EA5*000000*000008	(Price Setting Timestamp)YYMMDD*Hums
EA7*0*2	Power up/down cycles since last reset*Power up/down cycles since initialization

Note 1: PA1, PA2, PA4, PA5 Fields repeat for each valid Selection

Table 2: DEX/UCS Information.

Programming

Service Modes

The table on the right side of this page is a copy of the decal found inside the 965 Control Module. This decal provides a list of the service modes described in the following pages.

Access to the Service Mode, is granted upon opening of the main door. If a period of no activity occurs for 5 minutes, the controller will automatically revert to the Operate Mode. Entrance to the Service Mode clears any current credit. If no errors are present the following display will appear (Figure 13).



FIGURE 13: Initial Service Mode Screen when no errors are present.

To enter the Service Modes (see Figure 15) press the C key or use the numeric key pad to enter the Service Mode number.

If errors are present the error reporting screen will be displayed (see Figure 14). Use the ◀ and ▶ keys to scroll through the errors listed. Press the # key followed by the * key to clear the errors. To enter the Service Modes (see Figure 15) press the C key or use the numeric key pad to enter to the Service Mode number.

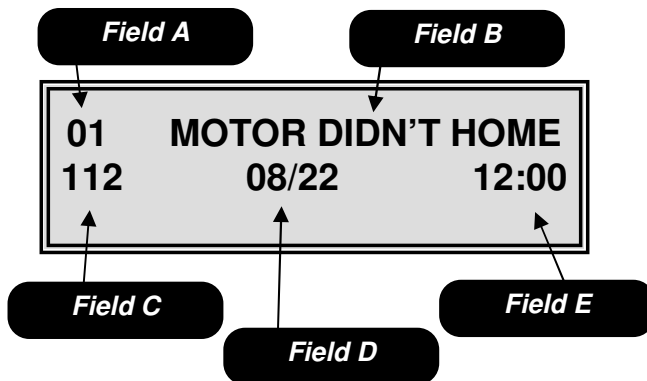

FIGURE 14: Initial Service Mode Screen when errors are present.

Field A is the sequential number of the error.

Field B is the error description field.

Field C is the motor number if applicable.

Field D is the date of the error.

Field E is the time of the error.

◆ See the Troubleshooting Section of this manual for specific information regarding the errors being reported.

AUTOMATIC PRODUCTS International, Ltd.	
LOGIC BOARD FLASH CODES	
LED Status	Meaning
On Steady	Controller is not functioning
Off	Power to LCB is off
1 slow flash	No devices are attached to MDB port, but the controller is working
1 flash	LCB has detected a chiller unit in main cabinet
2 flashes	LCB has detected a second cabinet (A LA CARTE)
3 flashes	LCB has detected an MDB coin mech
4 flashes	LCB has detected an MDB bill validator
5 flashes	LCB has detected an MDB cashless payment system
SERVICE MODES	
ACCOUNTABILITY	
01	Historical Accountability
02	Historical Sales By Selection
03	Interval Accountability
04	Interval Sales By Selection
05	Clear Interval Accountability
06	Print-out Accountability
MACHINE SETUP	
10	Tube Fill Mode
11	External Accountability
20	Price Assignment
21	Golden Eye Enable Setup.
22	Bill Escrow Setup
23	Motor Pairing
24	Winner Vend
25	Force Vend Setup
26	Multiple Vend Setup
27	Combo Vend
28	Free Vend Setup
29	Free Vend Coupon
30	Chip Load/Store
31	Setup Change Payback
32	Machine Lockout
33	Spiral Count
34	Speech/Chime Enable
35	Security
36	Space to Sales
37	Max Payout
REFRIGERATION SETUP	
40	Set Temperature
41	Set up Defrost
42	Health Shutdown By Selection
TIME FUNCTIONS	
50	Current Time
51	Timed Shutdown
52	Timed Discount
53	Timed Messages
MESSAGE SETUP	
60	User Messages
61	After Sale Message
62	Out Of Service Message
DIAGNOSTICS & SERVICE	
80	Test Vend
81	Sequential Event Log
82	Service Log
83	Temperature Log
84	Test Baffle Door
TO VIEW AND CLEAR ERRORS:	
If errors exist, they will be shown on the display upon entering the service mode or by pressing C to exit a service mode.	
Use ▶ or ◀ to scroll through the errors.	
Press # then * to clear errors.	
FOR ADDITIONAL INFORMATION ABOUT ANY OF THESE SERVICE MODES, REVIEW THE OPERATING SYSTEM SECTION OF THE SERVICE MANUAL!	
Rev 1.5/23/05 P/N 17400152	

Programming

Figure 15 shows the first screen encountered after pressing the C key in either of the previous two screens (Figure 13 and Figure 14). Use the ◀ or ▶ keys to scroll sequentially through the modes or use the numeric key pad to enter the Service Mode number.

Entering one of the Service Mode numbers shown on the following pages allows you to access that Service Mode. **Example: entering 20 will take you into the Price Assignment Mode.**

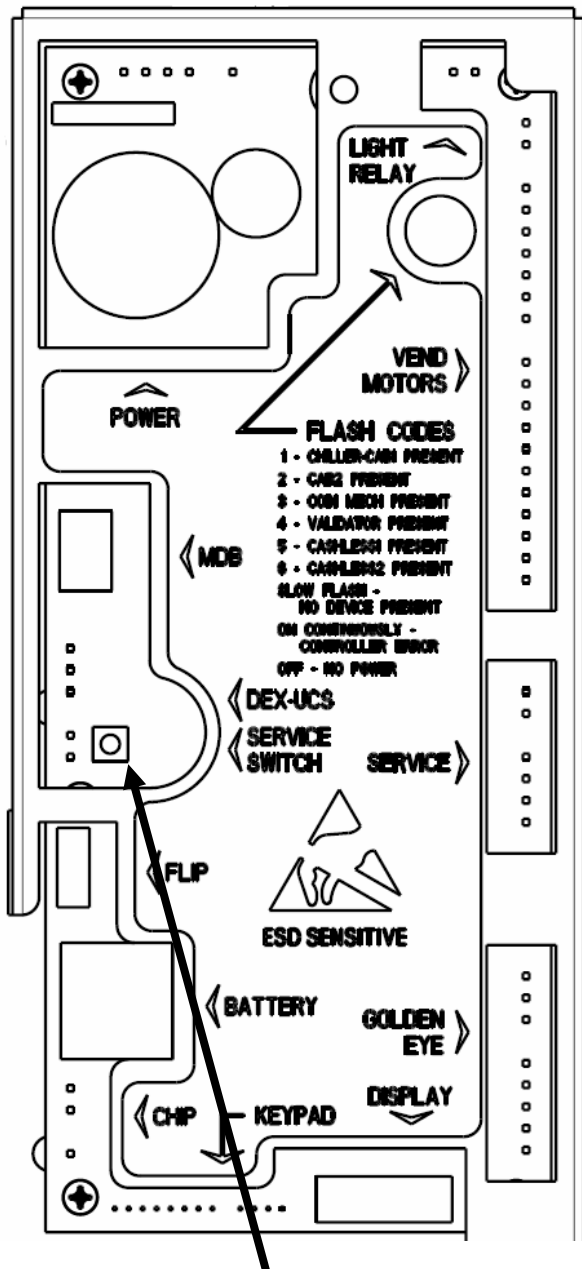

Figure 16: Location of Service Switch.

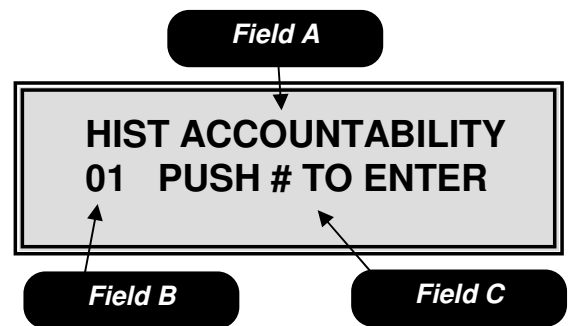



FIGURE 15: First Service Mode Number Screen.

Field A is the mode name.
Field B is the mode number.
Field C is the mode entering instructions.
 Use the ◀ or ▶ keys to scroll sequentially through the mode numbers.



Important Software Change

Prior to revision 21 software the Service Mode Switch will need to be pressed before entering the Service Modes. See Figure 16 for the location of the Service Switch.

Programming

Mode 01 – Historical Accountability

Mode 01 is used to view the historical accountability. To access this mode, press the **Historical Sales Data Fast Track Key** or press **01** on the numeric keypad.

Pressing either the ◀ or ▶ key will sequence you through the historical accountability fields in the order shown in the table below. To exit this mode, press the **C** key or press the Service Switch.

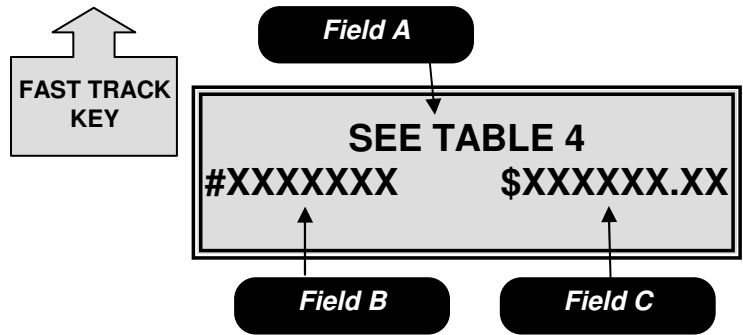

Mode 01 – Historical Accountability

Field A is the accountability name field.
Field B is the total vend count field.
Field C is the total value field.

◆ When a data field begins with a # symbol this indicates a vend counter. When the data field begins with a \$ sign this indicates a cash value.

FIELD A	DESCRIPTION
The display will show	
HIST PAID SALES #0000000 \$0000000.00	Total Value of Sales
HIST NUMBER TESTS #0000000	# of Test Vends
HIST FREE VENDS #0000000 \$0000000.00	Free Vends
HIST CASH VENDS #0000000 \$0000000.00	Cash Sale
HIST VALUE BILLS \$000000	Value of Bills Stacked
HIST VALUE CASH \$0000000.00	Value of Cash In
HIST VALUE TUBE \$0000000.00	Value of Coins to Tubes
HIST VALUE BOX \$0000000.00	Value of Coins Routed to Cash Box
HIST VALUE DISP \$0000000.00	Value of Cash Dispensed
HIST VALUE MDISP \$0000000.00	Value of Cash Manually Dispensed
HIST VALUE ECV \$0000000.00	Value of Exact Change Vends
VALUE TUBE COINS \$0000.00	Current Value of Coins in Tubes
HIST TOKEN VENDS #0000000 \$0000000.00	Token Vends
HIST CASHLESS VENDS #0000000 \$0000000.00	# of Cashless Vends
HIST CAN VENDS #0000000 \$0000000.00	Can Vends
HIST CAB 1 VENDS #0000000 \$0000000.00	Cab 1 Vends
HIST CAB 2 VENDS #0000000 \$0000000.00	Cab 2 Vends
GOLDEN EYE REVISIONS CAB1 00 CAB2 00	Golden Eye Software Revision
HIST NUMBER GE #0000000	# OF Golden Eye Spiral Turns

Table 4: Historical accountability fields.

Programming

Mode 02 – Historical by Selection

Mode 02 is used to view the historical accountability by selection. To access this mode, press the **Historical Sales by Selection Fast Track Key** or press **02** on the numeric keypad.

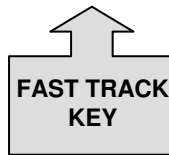

Pressing either the ◀ or ▶ key will sequence you through the selections or use the numeric key pad to enter a selection number into Field A. Field B shows date and Field C shows you the time of the last vend for the selection shown in Field A. Field D shows you the number of vends and Field E shows you the total dollar value of vends for the item in Field A. To exit this mode, press the **C** key or press the Service Switch.

◆ **All time based information is dependent upon the clock on the control board being set correctly, see Mode 50.**

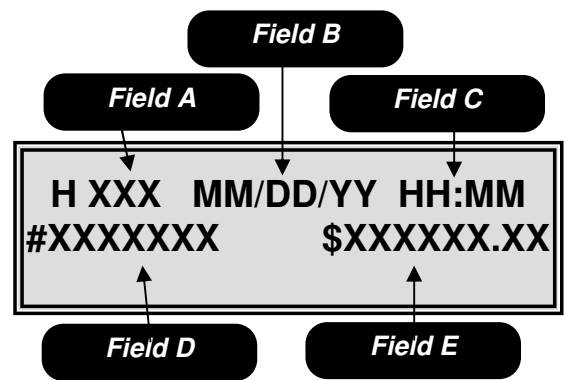

Mode 02 – Historical by Selection

Field A is the item number.

Field B is the date of the last vend for the item in Field A.

Field C is the time of the last vend for the item in Field A.

Field D is the number of vends for the item in Field A

Field E is the historical dollar value of all vends for the item in Field A.

Mode 03 – Interval Accountability

Mode 03 is used to view the interval accountability. To access this mode, press the **Interval Sales Data Fast Track Key** or press **03** on the numeric keypad.

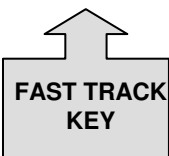

Pressing either the ◀ or ▶ key will sequence you through the interval accountability fields in the order shown in the table below. To exit this mode, press the **C** key or press the Service Switch.

◆ **All interval data is reset to zero under the following two conditions.**

1. A successful DEX download is performed, or
2. Mode 05 is used to clear the Interval data.

This also applies to the Interval data in Modes 04 and 06.

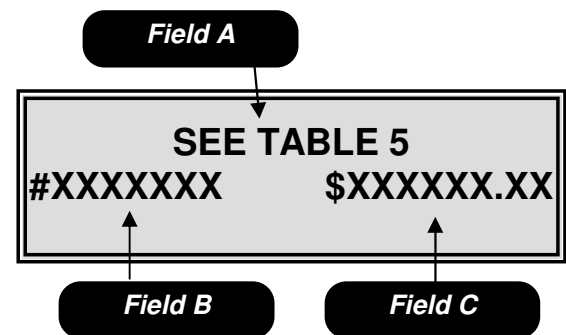

Mode 03 – Interval Accountability

Field A is the accountability name field.

Field B is the interval vend count field.

Field C is the interval dollar value field.

Programming

Mode 04 – Interval by Selection

Mode 04 is used to view the interval accountability by selection. To access this mode, press the **Interval Sales by Selection Fast Track Key** or press **04** on the numeric keypad.

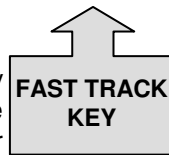

Pressing either the ◀ or ▶ key will sequence you through the selections or use the numeric key pad to enter a selection number into Field A. Field B shows date and Field C shows you the time of the last vend for the selection shown in Field A. Field D shows you the number of vends and Field E shows you the dollar value of vends for the item in Field A. To exit this mode, press the **C** key or press the Service Switch.

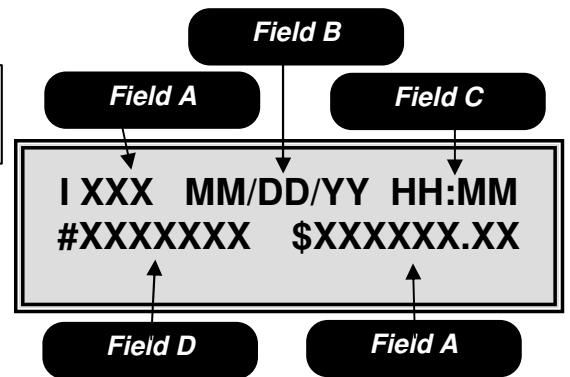

Mode 04 – Interval by Selection

Field A is the item number.

Field B is the date of the last vend for the item in Field A.

Field C is the time of the last vend for the item in Field A.

Field D is the number of vends for the item in Field A

Field E is the dollar value of the vend for the item in Field A.

◆When the security option in Mode 35 is enabled only Modes 01 through 04 will be accessible without a password. Attempting to access any other Mode will prompt the operator to enter the correct password.

FIELD A The display will show	DESCRIPTION
INTR PAID SALES #0000000 \$0000000.00	Total Value of Sales
INTR NUMBER TESTS #0000000	# of Test Vends
INTR FREE VENDS #0000000 \$0000000.00	Free Vends
INTR CASH VENDS #0000000 \$0000000.00	Cash Sale
INTR VALUE BILLS \$000000	Value of Bills Stacked
INTR VALUE CASH \$0000000.00	Value of Cash In
INTR VALUE TUBE \$0000000.00	Value of Coins to Tubes
INTR VALUE BOX \$0000000.00	Value of Coins Routed to Cash Box
INTR VALUE DISP \$0000000.00	Value of Cash Dispensed
INTR VALUE MDISP \$0000000.00	Value of Cash Manually Dispensed
INTR VALUE ECV \$0000000.00	Value of Exact Change Vends
VALUE TUBE COINS \$0000.00	Current Value of Coins in Tubes
INTR TOKEN VENDS #0000000 \$0000000.00	Token Vends
INTR CASHLESS VENDS #0000000 \$0000000.00	# of Cashless Vends
GOLDEN EYE REVISIONS CAB1 00 CAB2 00	Golden Eye Software Revision
INTR NUMBER GE #0000000	# OF Golden Eye Spiral Turns

Table 5: Interval accountability fields.

Programming

Mode 05 – Clear Interval Data

Mode 05 is used to clear the interval data. To access this mode, press **05** on the numeric keypad.

Upon entering the display will show “CLEAR INTERVAL DATA”. Pressing the **#** key followed by the ***** key will clear all interval data. To exit this mode without clearing the data, press the **C** key or press the Service Switch.

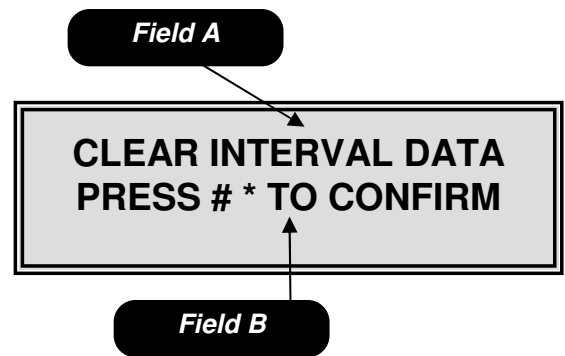

Mode 05 – Clear Interval Data
Field A is the mode identification field.
Field B is the instruction field.

Mode 06 – Print out Accountability

Mode 06 is used to transmit the MIS information to a printer. To access this mode, press **06** on the numeric keypad.

Press the **#** key to send all historical and interval accountability including data by selection. Use the ***** key to send all historical and interval data but not send the data by selection, for specific details of what is included in each list see Table 6. To exit this mode, press the **C** key or press the Service Switch.

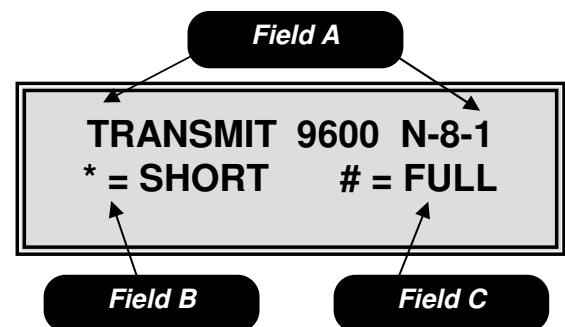

Mode 06 – Print out Accountability.
Field A shows the transmission characteristics for the printer.
Field B is the short list download instruction field.
Field C is the full list download instruction field.

Table 6 Notes

- ◆ An (H) at the end of the definition means historical data.
- ◆ An (I) at the end of the definition means Interval data.
- ◆ The column heading titled F is the full list.
- ◆ The column heading titled S is the short list.
- ◆ Fields highlighted in bold are repeated for each valid selection in the machine.

- ◆ **Pressing button 1 while at the “Print out Accountability” screen will result in the full list being printed at a faster speed.**

- ◆ **See Page 5.32 for information regarding the setting of a Serial Number, Machine id and Location id.**

Programming

Mode 06 - Continued

Field	Definition	F	S
ID101	Machine Serial #	X	X
ID102	Machine ID #	X	X
ID103	Machine Version #	X	X
ID104	Machine Location	X	X
ID106	Machine Asset #	X	X
ID501	System Date	X	X
ID502	System Time	X	X
ID703	Manufacturer Code	X	X
CB101	LCB Serial #	X	X
CB102	LCB ID #	X	X
CB103	LCB Software Version	X	X
ID401	Decimal Point Position	X	X
ID402	Country Code	X	X
ID403	Currency Code	X	X
VA101	Value of all Paid Sales (H)	X	X
VA102	Number of all Sales (H)	X	X
VA103	Value of all Paid Sales (I)	X	X
VA104	Number of all Sales (I)	X	X
VA105	Value of Discounted Sales (H)	X	X
VA106	Number of Discounted Sales (H)	X	X
VA107	Value of Discounted Sales (I)	X	X
VA108	Number of Discounted Sales (I)	X	X
VA201	Value of Test Vends (H)	X	X
VA202	Number of Test Vends (H)	X	X
VA203	Value of Test Vends (I)	X	X
VA204	Number of Test Vends (I)	X	X
VA301	Value of Free Vends (H)	X	X
VA302	Number of Free Vends (H)	X	X
VA303	Value of Free Vends (I)	X	X
VA304	Number of Free Vends (I)	X	X
BA101	Bill Validator Serial Number	X	X
BA102	Bill Validator ID Number	X	X
BA103	Bill Validator Software Version	X	X
CA101	Coin Changer Serial Number	X	X
CA102	Coin Changer ID Number	X	X
CA103	Coin Changer Software Version	X	X
CA201	Value of Cash Sales (H)	X	X
CA202	Number of Cash Sales (H)	X	X
CA203	Value of Cash Sales (I)	X	X
CA204	Number of Cash Sales (I)	X	X
CA308	Value of Bills Stacked (H)	X	X
CA304	Value of Bills Stacked (I)	X	X
CA305	Value of Cash in (H)	X	X
CA301	Value of Cash in (I)	X	X
CA307	Value of Coins to Tubes (H)	X	X
CA303	Value of Coins to Tubes (I)	X	X
CA306	Value of Cash to Cashbox (H)	X	X
CA302	Value of Cash to Cashbox (I)	X	X
CA3010	Value of Bills Stacked (H)	X	X
CA309	Value of Bills Stacked (I)	X	X
CA403	Value of Cash Dispensed (H)	X	X
CA401	Value of Cash Dispensed (I)	X	X
CA404	Value of Cash Manually Dispensed (H)	X	X

Field	Definition	F	S
CA402	Value of Cash Manually Dispensed (I)	X	X
CA702	Value of Cash Dispensed (H)	X	X
CA701	Value of Cash Dispensed (I)	X	X
CA704	Number of Cash Dispensed (H)	X	X
CA703	Number of Cash Dispensed (I)	X	X
CA902	Value of Exact Change Vends (H)	X	X
CA901	Value of Exact Change Vends (I)	X	X
CA1002	Tube Fill Value (H)	X	X
CA1001	Tube Fill Value (I)	X	X
CA1501	Current Value of Coins in Tubes (H)	X	X
MA501	Combo Vend Header	X	X
MA502	Value of Discount for Combo Vends (H)	X	X
MA504	Value of Discount for Combo Vends (I)	X	X
MA503	Number of Combo Vends (H)	X	X
MA505	Number of Combo Vends (I)	X	X
MA502	Value of Winner Vends (H)	X	X
MA504	Value of Winner Vends (I)	X	X
MA503	Number of Winner Vends (H)	X	X
MA505	Number of Winner Vends (I)	X	X
TA202	Number of Token Vends (H)	X	X
TA204	Number of Token Vends (I)	X	X
TA201	Value of Token Vends (H)	X	X
TA203	Value of Token Vends (I)	X	X
DA101	Cashless Serial Number	X	X
DA102	Cashless ID Number	X	X
DA103	Cashless Software Version Number	X	X
DA201	Value of Cashless Vends (H)	X	X
DA203	Value of Cashless Vends (I)	X	X
DA202	Number of Cashless Vends (H)	X	X
DA204	Number of Cashless Vends (I)	X	X
PA101	Can	X	X
PA202	Value of Can Vends (H)	X	X
PA201	Number of Can Vends (H)	X	X
PA103	Selection Number Header	X	X
PA102	Price	X	X
PA107	Selection Status	X	X
PA202	Value of Vends by Selection (H)	X	
PA204	Value of Vends by Selection (I)	X	
PA201	Number of Vends by Selection (H)	X	
PA203	Number of Vends By Selection (I)	X	
PA401	Number of Free Vends by Selection (H)	X	
PA501	Time and Date of Last Vend (H)	X	
PA502	Time and Date of Last Vend (I)	X	
LE101	Loop Trailer	X	X
EA301	Number of Reads with Reset	X	X
EA309	Number of Reads	X	X
EA3010	Number of MIS Resets	X	X
EA401	Date of Initialization	X	X
EA402	Time of Initialization	X	X

*Items highlighted in bold repeat for each valid selection.

Table 6: MIS Definitions.

Programming

Mode 10 – Tube Fill

Mode 10 allows you to fill the coin mech and the logic board will count the money as it goes in and continually track the coin mech inventory. This is the count the board uses when you choose tube leveling as the payout type in Mode 31. To access this mode, press the **Tube Fill Fast Track Key** or press **10** on the numeric keypad.

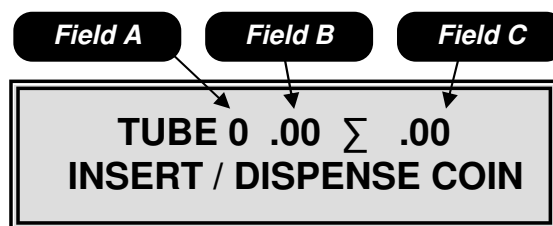
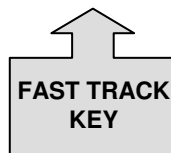

Upon entering the tube fill mode the controller will display the current status of the coin tubes. As coins are inserted into the top of the changer, the display will show the tube the coin was saved to in Field A, the value of all coins in that tube in Field B and the total dollar amount of coins in the changer in Field C. Coins may be dispensed by using the switches on the coin mech. To exit this mode, press the **C** key or press the Service Switch.

Mode 10 – Tube Fill

Field A is the tube number the coin was saved to.

Field B is the value of coins in the tube identified in Field A.

Field C is the total value of coins in the changer.

◆ **Before using the machine for the first time, the coin mech must have a minimum of \$5 in the coin tubes to permit the acceptance of bills.**

Mode 11 – External Accountability

Mode 11 is used to permit you or your customer, via a password, to review the total vend count and total cash accepted by the machine. To access this mode, press **11** on the numeric keypad.

Pressing either the ◀ or ▶ key will allow you to toggle back and forth between the fields.

Upon entering the external accountability setup mode, the display will show the current external accountability state. Use the numeric key pad to set a 4 digit security code in field A. Toggle to field B use the # key to turn the external accountability function on (Y) or off (N). To exit this mode, press the **C** key or press the Service Switch.

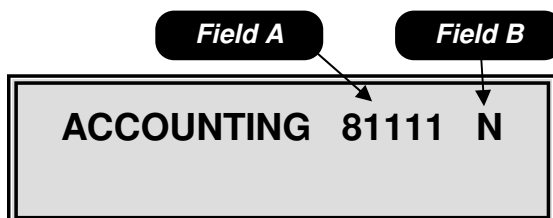

Mode 11 – External Accountability

Field A is the security code field.

Field B is the feature on/off field.

Note

◆ If enabled, instruct the customer/contact to enter 8 and then the 4 digit code. The display will show the total vend count in Field C and the total value in Field D.

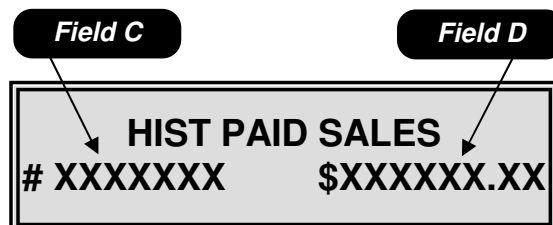

Mode 11 – Customer Viewable Data

Field C is the total vend count field.

Field D is the total value field.

Programming

Mode 20 – Price Assignment

Mode 20 is used to assign the standard price for all selections in the machine. To access this mode, press the **Set Price Fast Track Key** or press **20** on the numeric keypad.

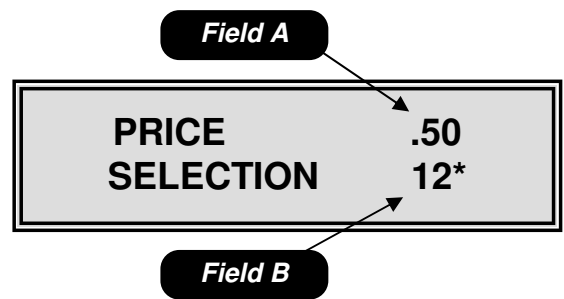
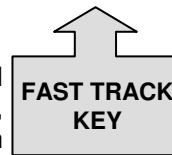

Pressing either the ◀ or ▶ key will allow you to toggle back and forth between the fields.

Use the numeric keypad to enter the price in Field A, then toggle to Field B to assign the current price to a selection. To exit this mode, press the **C** key or press the Service Switch.

Mode 20 – Price Assignment
Field A is the price setting field.
Field B is the selection assignment field.

Note

- ◆ The maximum price allowed is \$99.99.

Special Actions

- ◆ Setting selections with a blank price disables that selection which means DEX information will no longer be transferred or displayed for items disabled in this way. The blank price is set by depressing the # Key.
- ◆ The * key can be used as a wildcard in Field B to set entire rows (12*) or the entire machine (1**).
- ◆ After assigning the prices, make sure you adjust the scrolling price tabs to reflect the current or new price.

◆ **You can use the ◀ or ▶ key while in the operate mode with the door open to check the prices in the machine.**

Mode 21 – Golden Eye Enable Setup

Mode 21 is used to set up the Golden Eye Guarantee Delivery System. To access this mode, press the **Golden Eye Fast Track Key** or press **21** on the numeric keypad.

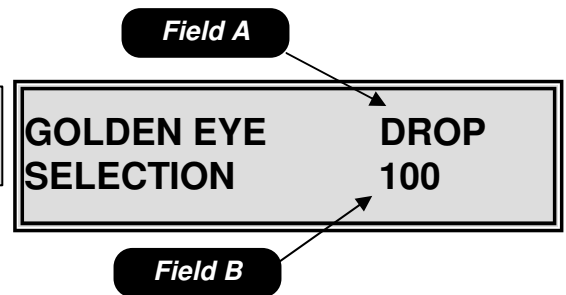
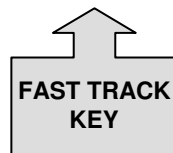

Upon entering the Golden Eye setup mode, the display will show the current Golden Eye state in Field A. Toggle between the available options in Field A by using the # key. Each selection affected by the setting in Field A are shown in sequence in Field B, use the ◀ or ▶ key to scroll through these selections. Use the numeric keypad to add selections in Field B. To remove a selection from Field B, press the # key while the selection number is displayed. To exit this mode, press the **C** key or press the Service Switch.

Mode 21 – Golden Eye Enable Setup
Field A is the Golden Eye option setting field.
Field B is the selection assignment field.

Programming

Mode 21 - Continued

Available Options

Drop – The motor will stop as soon as the product is detected after the first complete revolution.

Home – The motor will home before stopping.

Off – Golden Eye is disabled, the motor will stop as soon as it reaches home whether a product has been delivered or not.

Special Actions

- ◆ The * key may be used as a wildcard to set the entire rows (12*) or the entire machine (1**).
- ◆ To delete all selections press the # key then the * key in sequence.

◆ **To home motors left off home in the DROP mode, open the door and press the “C” key, then close the door.**

Mode 22 – Bill Escrow Setup

Mode 22 is used to set the bill escrow option. To access this mode, press the \$ **Escrow Fast Track Key** or press **22** on the numeric keypad.

Upon entering the bill escrow set up mode, the display will show the current bill escrow state in Field A. Use the # key to toggle between the available options in Field A. To exit this mode, press the **C** key or press the Service Switch.

Available options

First – The machine will hold the first bill deposited in escrow until a vend is initiated. Once a vend is initiated the bill must be stacked before the product will be dispensed. In this mode only one bill will be accepted. If the coin return is depressed, the bill will be returned to the customer.

Last – The machine will accept bills to the highest vend price. If the coin return is depressed the last bill inserted will be returned and all previous bills inserted will be returned in change.

Off – All bills accepted will be stacked immediately. If the coin return is depressed, change will be paid back.

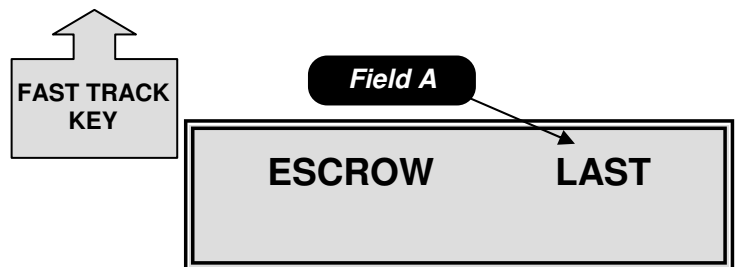

Mode 22 – Bill Escrow Setup
Field A is the escrow setting field.

Programming

Mode 23 – Motor Pairing

Mode 23 is used to pair an even numbered motor with the next sequential odd numbered motor. To access this mode, press the **Pair Motor Fast Track Key** or press **23** on the numeric keypad.

Upon entering the motor pairing set up mode, the display will show “100 PAIRED TO”. Use the numeric key pad to enter the even numbered motor to be paired in Field A. The odd numbered motor next in sequence will automatically appear in Field B. Use the ◀ or ▶ keys to scroll through the list of paired motors. Use the # key to remove a previously paired combo. To exit this mode, press the **C** key or press the Service Switch.

Notes

- ◆ Only motors in the same row of a machine may be paired.
- ◆ All pricing, discounting and vending options are set using the selection number of the left motor in the pair.
- ◆ Any even number motor may be paired to the next odd numbered motor in sequence. (e.g. 110 will always be paired with 111, 112 with 113, etc)

Mode 24 – Winner Mode

Mode 24 is used to set the frequency that free items will be awarded during cash vends only. To access this mode, press **24** on the numeric key pad.

Pressing either the ◀ or ▶ key will allow you to toggle back and forth between the fields.

Upon entering the Winner Mode, the display will show the current winner setting in Field A. Use the numeric key pad to enter the number of vends between winners up to 9999, then toggle to Field B, use the # key to turn the Winner Mode on (Y) or off (N). To exit this mode, press the **C** key or press the Service Switch.

When a customer wins, the credit will be returned the beeper will sound 5 times and the display will show “**WE HAVE A WINNER!!**”.

Notes

- ◆ Vends made while on free vend, test vend or the second vend of a combo vend are not counted for the purpose of determining the winner.
- ◆ Setting the number to 0000 will result in every vend being a winner.

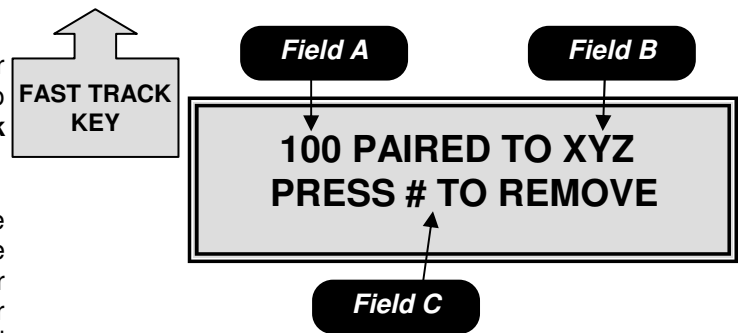

Mode 23 – Motor Pairing

Field A is the even motor number to be paired.

Field B is the odd number motor to be paired this number will automatically appear once a selection is entered in field A.

Field C is the instructions to remove a previously set motor pair.

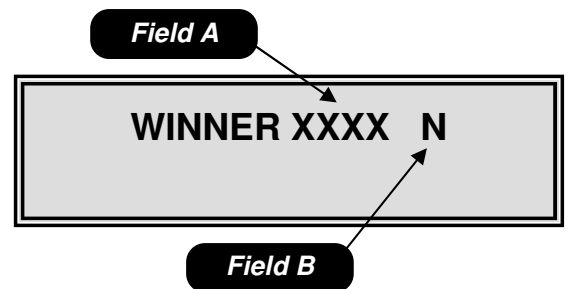

Mode 24 – Winner Mode

Field A is the number of vends between winners.

Field B is the winner on/off field.

Programming

Mode 25 – Force Vend Setup

Mode 25 is used to set the force vend option. To access this mode, press **25** on the numeric keypad.

Upon entering the force vend mode, the display will show the current force vend state. Use the **#** key to toggle between on and off in Field A. To exit this mode, press the **C** key or press the Service Switch.

Available options

On – The customer must purchase an item before any credit will be returned.

Off – The customer may receive their money back at any time.

Notes

- ◆ Force vend does not apply to the use of debit cards or to bills held in escrow, only to non-tube coins.

Mode 26 –Multi-vend Setup

Mode 26 is used to set the multi-vend option. Multi-vend allows the customer to make an additional selection using the change amount due from the prior vend. To access this mode, press **26** on the numeric keypad.

Pressing either the ◀ or ▶ key will allow you to toggle back and forth between the fields.

Upon entering the multi-vend mode the display will show the current multi-vend state. Use the **#** key to toggle between on and off, then toggle to Field B to change the time-out setting, the default setting is 30 seconds if a larger time-out setting is desired use the numeric key pad to enter the larger time. To exit this mode, press the **C** key or press the Service Switch.

Available options

On – Allows customer to make additional selections as long as sufficient credit exists to purchase the lowest priced item in the machine. The customer may establish additional credit at any time when in this mode. If the customer presses the coin return lever, or the amount of available credit drops below the lowest price in the machine or the time-out expires, change is returned regardless of the state of multi-vend.

Off – Change will be returned immediately after the sale.

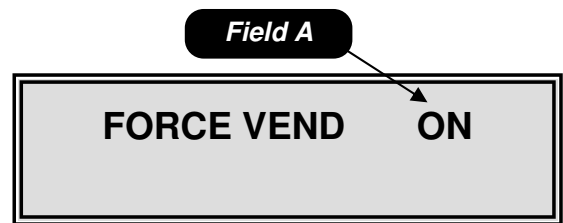

Mode 25 – Force Vend Setup
Field A is the force vend on/off field.

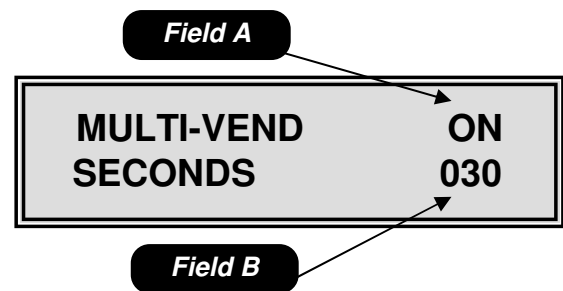

Mode 26 – Multi-vend Setup
Field A is the multi-vend on/off field.
Field B is the time-out field; the default time is 30 seconds. The available range is 5 to 90 seconds.

Programming

Mode 27 – Combo Vend Setup

Mode 27 is used to set the combo vend feature. A combo vend allows you to set up a selection to be offered in conjunction with another selection. To access this mode, press **27** on the numeric keypad.

Pressing either the ◀ or ▶ key will allow you to toggle back and forth between the fields.

Upon entering the combo vend mode the display will show the current combo vend state. Use the # key to toggle between on (Y) and off (N) in Field A, then toggle to Field B use the numeric key pad to set the time out value in seconds. The time-out value is the number of seconds the customer has to add additional credit in order to purchase a combo vend combination. Then toggle to Field C use the # key to set a unique number for the combination, this number is settable from 0 to 9 allowing for 10 different combinations at any 1 time. Then toggle to Field D and use the numeric key pad to set the item that is to be selected by the customer, then toggle to Field E and use the numeric key pad to select the item to be offered in combination with the customer selected item. Then toggle to Field F and use the numeric key pad to set the discount amount of the combination item. Then toggle to Field G and use the # key turn the selected combination vend on (Y) or off (N). To exit this mode, press the **C** key or press the Service Switch.

Notes

- ◆ Setting the discount amount in Field F to \$99.99 will allow the discounted item to be vended for free.
- ◆ Wild carding with the * key is not allowed in the combo vend.
- ◆ When combo vend is active, the display will scroll the message “**FEATURED ITEM *** BUY XXX AND SAVE \$ ON YYY**”.

Mode 28 – Free Vend Option

Mode 28 is used to set the free vend option. To access this mode, press **28** on the numeric keypad.

Upon entering the free vend option mode the display will show the current free vend state. Use the # key to toggle the free vend on or off in Field A. To exit this mode, press the **C** key or press the Service Switch.

Note

- ◆ Free vend applies to the entire machine.

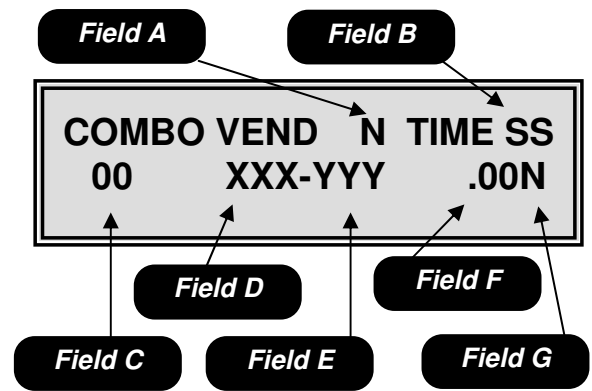

Mode 27 – Combo Vend Setup

Field A is the global combo vend on/off field.

Field B is the time-out field measured in seconds.

Field C is the number assigned to the combo vend.

Field D is the item selected by the customer.

Field E is the item to be vended in combination with the customer selected item.

Field F is the discount amount of the combination item.

Field G allows the user to turn the combination item on or off. But leave the rest of the combination vends in use.

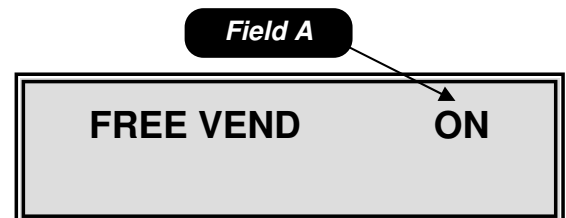

Mode 28 – Free Vend Option

Field A is the free vend option on/off field.

Programming

Mode 29 – Free Vend Coupon

Mode 29 is used to set the free vend coupon or token option. To access this mode, press **29** on the numeric keypad.

Upon entering the free vend coupon mode the display will show Free Vend Coupon XXX in Field A, where XXX is the selection enabled for the free vend coupon. Each selection enabled for the free vend coupon is shown in sequence in Field A by depressing the ◀ or ▶ key. Use the numeric keypad to add selections. To remove a selection, press the # key while the selection number is displayed. To exit this mode, press the C key or press the Service Switch.

Special Actions

- ◆ The * key may be used as a wildcard to set entire rows (12*) or the entire machine (1**).

Mode 30 – Chip Retrieve/Store Mode

Mode 30 is used to retrieve or store information from the touch memory button (*CHIP*). To access this mode, press **30** on the numeric keypad.

To store all programmable information to *CHIP* press the * key as shown in Field B. To upload information previously stored on a *CHIP* press the # key as shown in field C. To exit this mode, press the C key or press the Service Switch.

- ◆ **To make sure that the information being transferred from the *CHIP* is compatible the software revision numbers will be compared before the transfer. If the version on the *CHIP* is not compatible the transfer is canceled and the display will show “CHIP NOT COMPATIBLE”.**

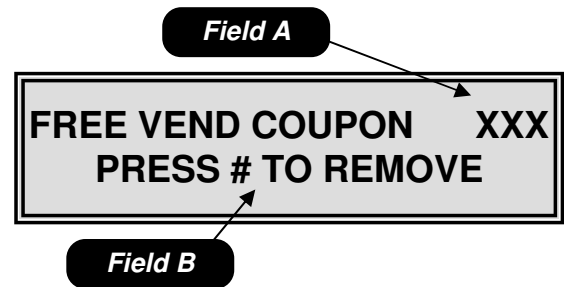

Mode 29 – Free Vend Coupon
Field A is the selection enabled field.
Field B is the selection remove field.

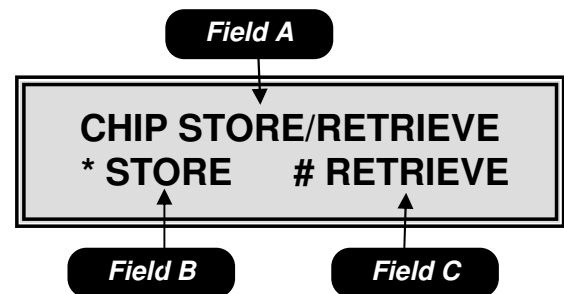

Mode 30 – Chip Retrieve/Store Mode
Field A is the name of the mode.
Field B is the download to *CHIP* function.
Field C is the upload from *CHIP* function.

Programming

Mode 31 – Change Payback Type

Mode 31 is used to set the change payback option. To access this mode, press **31** on the numeric keypad.

Upon entering the change payback mode, the display will show the current change payback state in Field A. Use the **#** key to toggle through the available options. To exit this mode, press the **C** key or press the Service Switch.

Available options

LEAST – The least amount of coins will be paid back.

LVL3 – The coin changer makes the payback decision based on how much money it thinks is in each tube. You should use the “Tube Fill” menu item (Mode 10) when you use this option.

Mode 32 – Selection Lockout

Mode 32 is used to lock selections from use in conjunction with an external switch. To access this mode, press **32** on the numeric keypad.

Upon entering the lockout mode the display will show LOCK SELECTION XXX in Field A. Where XXX is the selection enabled for lock out. Use the ◀ or ▶ key to scroll through each selection affected by the lockout. Use the numeric key pad to add selections. Use the **#** key while the selection number is displayed to remove selections. To exit this mode, press the **C** key or press the Service Switch.

Special actions

- ◆ The * key may be used as a wildcard.
- ◆ If all selections are disabled the lights will turn off and no money will be accepted.

Note

- ◆ The mechanical lockout of selections is done by adding an external key switch or other switch across pins P2-3 & P2-4 on the logic board.
- ◆ The machine will not function properly in shutdown when the door is open. The machine must **not** have the shut down switch active while the door is open.

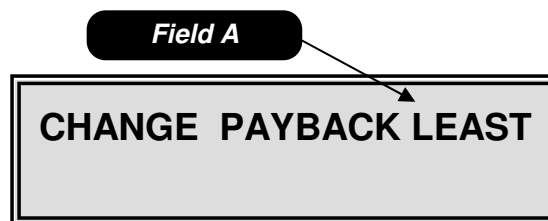
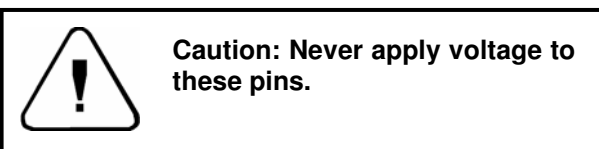

Mode 31 – Change Payback Type
Field A is the payback option selection field.

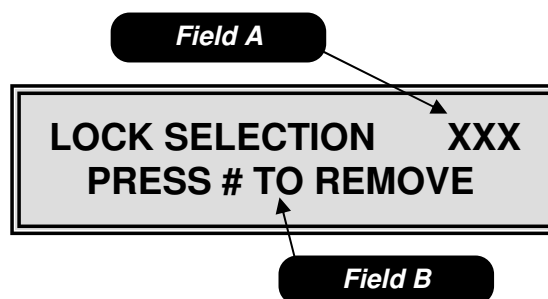

Mode 32 – Selection Lockout
Field A is the selection disable field.
Field B is the selection remove field.

Programming

Mode 33 – Set Spiral Count

Mode 33 is used to set the spiral count. Spiral count allows you to program the number of spaces in each spiral. When a selection has vended all product out of the individual spiral, the display will show 'SOLD OUT'. To access this mode, press **33** on the numeric keypad.

Pressing either the ◀ or ▶ key will allow you to toggle back and forth between the fields.

Upon entering the set spiral count mode the controller will display SPIRAL CNT OFF/ON in Field A. Use the # key to toggle between OFF/ON. If Field A is set to off no further action is needed.

If Field A is set to ON, Toggle to Field C and use the numeric key pad to enter the spiral count. Then toggle back to Field B and enter the selection numbers that correspond to the spiral count set in Field C. Repeat the above steps for each selection. To exit this mode, press the **C** key or press the Service Switch.

When Spiral Count is ON (Field A), each time the main cabinet door is opened, the display will prompt "STOCK MACHINE –Y". Pressing the # key with the Y showing will reset the spiral counts. Closing the door without pressing the # key, the sold out status of each spiral remains.

Special actions

- ◆ The * key can be used as a wildcard in Field B to set entire rows (12*) or the entire machine (1**).
- ◆ To disable a selection from spiral count set Field C to 0.

Note

- ◆ If this function is enabled, route service personnel must be instructed in its correct operation. Failure to correctly reset the counts will result in a full machine from vending properly.

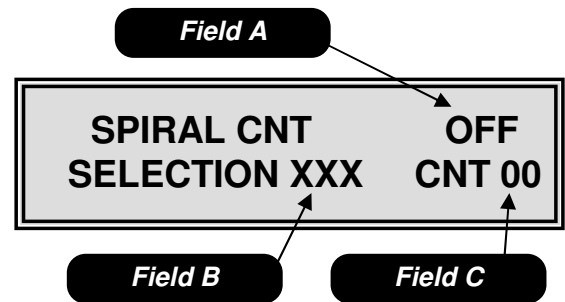

Mode 33 – Set Spiral Count
Field A is the spiral count on/off field.
Field B is the item selection field.
Field C is the spiral count field.

Programming

Mode 34 – Speech / Chime

Mode 34 is used to set the Speech/Chime options. To access this mode, press **34** on the numeric keypad.

Pressing either the ◀ or ▶ key will allow you to toggle back and forth between the fields.

Upon entering the speech/chime options mode, the controller will display the current SPEECH setting in field A and the current CHIME setting in Field B. The # key is used to toggle between on and off for each field. To exit this mode, press the **C** key or press the Service Switch.

Notes

- ◆ Turning the chime off will disable the beep from sounding in all conditions, except for the health code warning set in Mode 42.
- ◆ When Speech is on, all messages in the service mode will be transmitted via the DEX port for use with an audio interface.
- ◆ When Speech is on, the DEX/UCS port can no longer be used for any other communication.

Mode 35 – Security

Mode 35 is used to set the Security options. To access this mode, press 35 on the numeric keypad.

Pressing either the ◀ or ▶ key will allow you to toggle back and forth between the fields.

Upon entering the security mode, the current security settings will be displayed. Use the numeric key pad to set the desired security code in Field A, then toggle to Field B, use the # key to toggle between on (Y) and off (N). To exit this mode, press the **C** key or press the Service Switch.

With the security code, the service person will only be allowed access to Modes 01 to 04. Trying to enter any other modes will change the display to “ENTER SECURITY CODE”. Once the proper code has been entered all modes in the machine will be accessible until the service mode is exited.

Note

- ◆ Factory default settings are off (N) and a security code of 1111.
- ◆ **Once the service mode as been exited, the code must be re-entered to access Modes 05 through 84.**

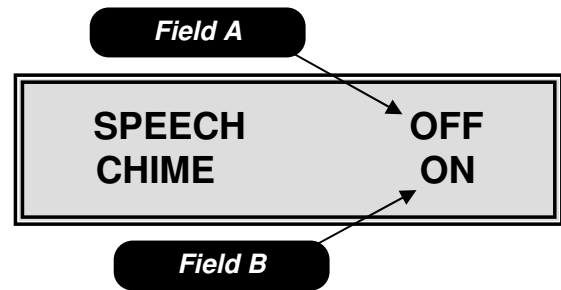

Mode 34 – Speech/Chime
Field A is the speech option field.
Field B is the chime option field.

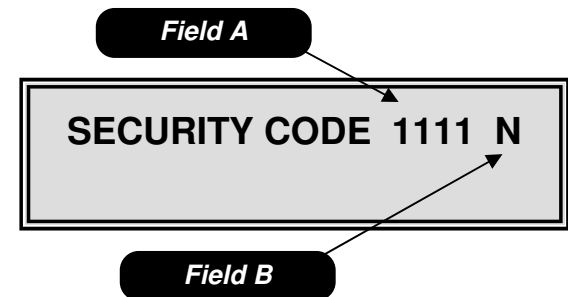

Mode 35 - Security
Field A is the security code entry field.
Field B is the security on/off field.

Programming

Mode 36 – Space to Sales

Mode 36 is used to set two columns to run together in a Space to Sales manner. To access this mode, press **36** on the numeric keypad.

Pressing either the ◀ or ▶ key will allow you to toggle back and forth between the fields.

Upon entering the Space to Sales mode, the display will show the current Space to Sales settings. Use the # key in Field A to turn the Space to Sales feature on (Y) or off (N). Toggle to Field B and use the # key to set a unique number for the space to sales combination. This number is settable from 0 to 9 allowing for 10 different Space to Sales combinations at any one time. Toggle to Field C and use the numeric keypad to set the first item number to be vended in a space to sales manner, then toggle to Field D and use the numeric keypad to set the second item number to be vended in a space to sales manner. Toggle to Field E, and use the # key to turn the selection numbers set in Field B to on (Y) or off (N). To exit this mode, press the **C** key or press the Service Switch.

◆ **Space to sales allows you to program two selection spirals to operate as one in an alternating method. For example if selection 110 is entered into Field C and selection 112 is entered into Field D, every time selections 110 or 112 are selected the product will be vended from spiral 110 one time and 112 the next time. It is important that any selections enabled in this mode contain the same product. The goal of space to sales is to increase the capacity of an individual item while preventing the inevitable empty spiral from occurring on a fast moving product.**

Mode 37 – Set Max Payout Mode

Mode 37 is used to set the Maximum Payout options. To access this mode, press **37** on the numeric keypad.

Pressing either the ◀ or ▶ key will allow you to toggle back and forth between the fields.

Upon entering the maximum payout mode, the controller will display the current max payout setting.

Toggle to Field A use the numeric keypad to set the maximum value of coins to be returned, then toggle to Field B and use the # key to turn on (Y) or off (N) the option. To exit this mode, press the **C** key or press the Service Switch.

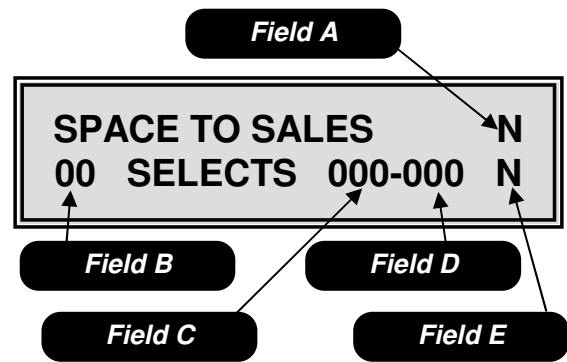

Mode 36 – Space to Sales

Field A is the space to sales on/off field.

Field B is the product type number field.

Field C is the first selection setting field.

Field D is the second selection setting field.

Field E is the product type on/off field

◆ **Caution – Space to Sales items must be priced identically.**

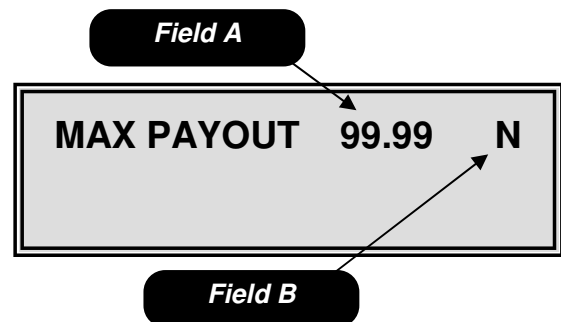

Mode 37 – Set Max Payout

Field A is the maximum coin payout field.

Field B is the maximum coin payout on/off field.

Programming

Mode 37 – Continued

Note

- ◆ When turned on (Y), if the credit after the sale is greater than the Max Payout set point in Field A, the machine will go into an automatic multi-vend (mode 26).

Mode 40 – Set Temperature

Mode 40 is used to set the Temperature of the cabinet(s). To access this mode, press the **Set Temp Fast Track Key** or press **40** on the numeric keypad.

Pressing either the ◀ or ▶ key will allow you to toggle back and forth between the fields.

Upon entering mode 40, the display will show the current temperature range setting. Field A is the cabinet selection field, use the # key to choose between 1 (cabinet 1) or 2 (cabinet 2). Then toggle to Field B to choose the temperature range option see below for the available options. Then toggle to Field C to set the temperature use the 1 key to raise or the 2 key to lower the temperature in Field F. Then toggle to Field E; use the # key to choose between Fahrenheit (F) and Celsius (C) temperature scales. To exit this mode, press the C key or press the Service Switch.

Temperature Range Options

AMBIENT – No temperature control. Field C will show ----- F.

ZONE – Not available in a 960.

FOOD – The target temperature in Field C is fixed at +36° F (2°C).

FROZEN – The target temperature in Field C is settable from -15° to +10° F (-12° to -26°C).

- ◆ The temperature is adjustable when Field B is set to FROZEN only.

- ◆ All temperature ranges have a + or – range of 3° F (2° C).

- ◆ The temperature inside the machine can be viewed from the outside by pressing and holding the # key for °F or * key for °C.

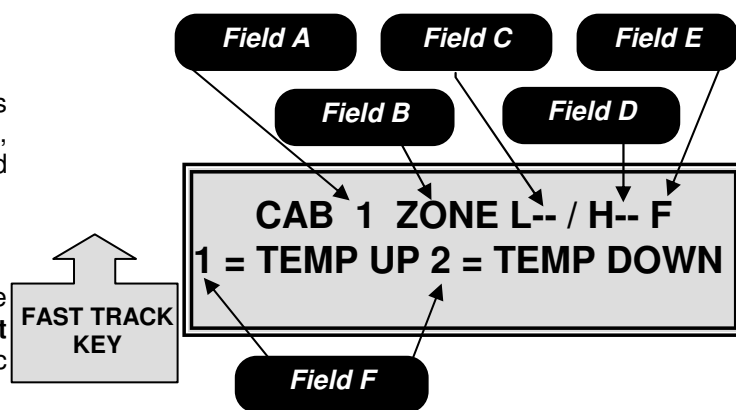

Mode 40 – Set Temperature for Cabinet 1

Field A is the cabinet selection field.

Field B is the temperature range selection field.

Field C is the temperature setting field for the can cube or the setting for a single zone machine.

Field D is only used on a dual zone machine, and is the temperature setting for the top half of the machine.

Field E is the temperature scale field, F for Fahrenheit or C for Celsius.

Field F is the temperature raising and lowering instruction field.

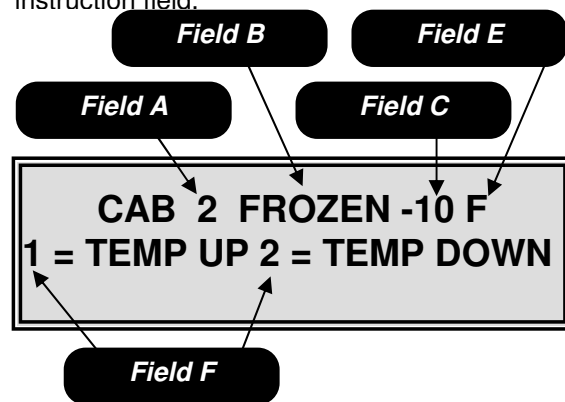

Mode 40 – Set Temperature for Cabinet 2

Field A is the cabinet selection field.

Field B is the temperature range selection field.

Field C is the temperature setting field. The default setting for frozen is -10°F.

Field D is the temperature scale field, F for Fahrenheit or C for Celsius.

Field E is the temperature raising and lowering instruction field.



When a new 930 Series machine is used to host a Model 960 Á LA CARTE merchandiser, the software on the Food Driver Board (FDB) **MUST** be Version 2.1 or higher. If the software is less than Version 2.1, you may experience repeated motor and baffle door errors. These errors will disable the Á LA CARTE. If you require new FDB software, please order P/N 360273.

Programming

Mode 41 – Defrost

Mode 41 is used to set the Defrost schedule and to start a Manual Defrost for the cabinet(s). To access this mode, press **41** on the numeric keypad.

Pressing either the ◀ or ▶ key will allow you to toggle back and forth between the fields.

Upon entering the Defrost setup mode, the display will show the current defrost settings. **Field A** is the cabinet selection field, use the # key to choose between cabinet 1 (1) or cabinet 2 (2). Then toggle to **Field B**, use the # key to set the defrost start time, in the 24 hour format. Then toggle to **Field C**, use the # key to choose between 6 or 8 hour time intervals between defrosting. To start an immediate defrost push the * key, the display will show “Defrost Starts in 2 Minutes”. To exit this mode, press the **C** key or press the Service Switch.

Mode 42 – Health Shutdown

Mode 42 is used to set the health shutdown options for the cabinet(s). To access this mode, press **42** on the numeric keypad.

◆ **This mode is not available in a 960. The health control in machines set to “FROZEN” or “FOOD” in Mode 40 is mandatory and CANNOT be turned off.**

Pressing either the ◀ or ▶ key will allow you to toggle back and forth between the fields.

Upon entering the health shutdown mode, the display will show the current health shutdown state. Use the numeric key pad to enter the selection numbers to be “health controlled” in **Field A**. Toggle to **Field B**, use the # key to turn the health shutdown on or off for the selected items. Repeat the above steps for each selection. If you would like a chime to sound when a health shutdown has occurred toggle to **Field C**, use the # key to turn the chime on or off. To exit this mode, press the **C** key or press the Service Switch.

Special actions

◆ The * key can be used as a wildcard in **Field A** to set entire rows (12*) or the entire machine (1**).

◆ **If the machine detects a Health Code error and the chime feature is ON the control board will sound a double beep every 30 seconds until the Health Code error is corrected.**

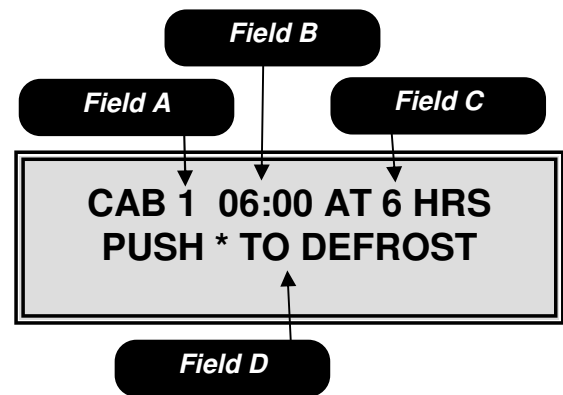

Mode 41 - Defrost

Field A is the cabinet selection field.

Field B is the time in the 24 hour format to start the defrost cycle.

Field C is the interval in hours between each defrost cycle settable to 6 or 8.

Field D is the information to start an immediate defrost cycle.

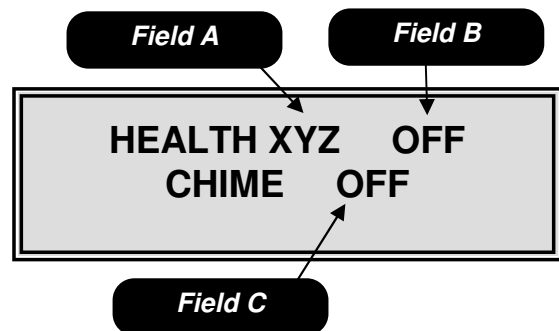

Mode 42 – Health Shutdown

Field A is the item selection field.

Field B is the health shutdown on/off field.

Field C is used to turn on/off the health shutdown notification chime.

Programming

Mode 50 – Current Time

Mode 50 is used to set the current time date, date format and daylight saving options. To access this mode, press the **Clock Fast Track Key** or press **50** on the numeric keypad.

Pressing either the ◀ or ▶ key will allow you to toggle back and forth between the fields.

Upon entering the Current Time mode, the display will show the current time (in 24 hour military time) and date settings. Use the numeric key pad to change the hour setting in Field A, then toggle to Field B and use the numeric key pad to set the minutes. Toggle to Field C, use the numeric key pad to set the month, then toggle to Field D, use the numeric key pad to set the day, then toggle to Field E, use the numeric key pad to set the year. Use the # key to save the settings to memory. Toggle to Field F; use the # key to choose the date format from the available options shown below. Toggle to Field G to change the daylight savings time zone setting using the available options shown below. To exit this mode, press the **C** key or press the Service Switch.

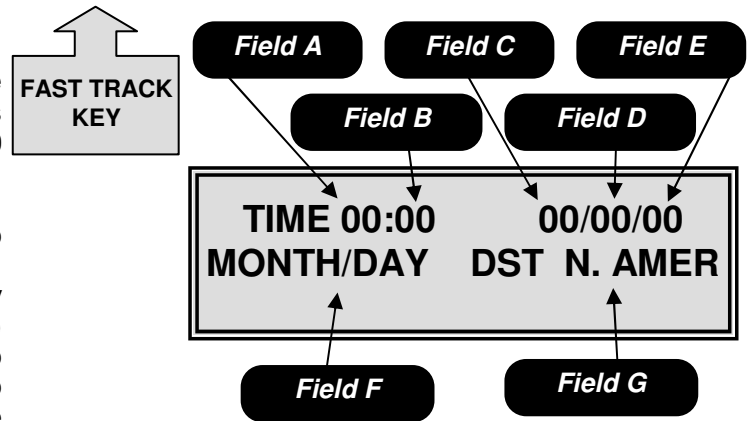

Mode 50 – Current Time

Field A is the hour setting field (24 hour military time).

Field B is the minute setting field.

Field C is the month setting field.

Field D is the day setting field.

Field E is the year setting field.

Field F is the date format field.

Field G is the daylight savings selection field.

◆ You must press the # key to save any changes to memory!

Field F available options

MONTH/DAY – This option will show the date in the Month/Day/Year format (mmdyy).

DAY/MONTH – This option will show the date in the Day/Month/Year format (ddmmy).

Field G available options

OFF – Does not follow daylight savings time.

N.AMER – Will automatically adjust to North American daylight savings time with a 1 hour increase on the 2nd Sunday in March and a 1 hour decrease the 2nd Sunday in November.

UK/EUR – Will automatically adjust to European daylight savings time with a 1 hour increase on the last Sunday in March and a 1 hour decrease on the last Sunday in October.

AUSLIA – Will automatically adjust to Australian daylight savings time with a 1 hour increase on the last Sunday in October and a 1 hour decrease on the last Sunday in March.

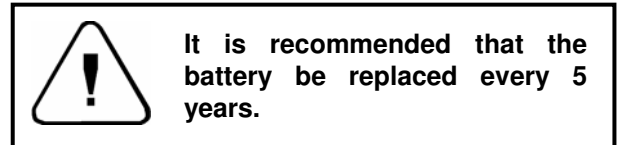

Programming

Mode 51 – Timed Shutdown

Mode 51 is used to set timed machine shutdown periods. The shutdown periods affect the ability of the machine to vend and the appearance of the machine. To access this mode, press the **Set Shutdown Fast Track Key** or press **51** on the numeric keypad.

Pressing either the ◀ or ▶ key will allow you to toggle back and forth between the fields. Upon entering the timed shutdown mode, the display will show the current shutdown setting. Use the # key in Field A to set the shutdown period number; this number may be set from 1 to 4 allowing for up to 4 different shutdown time periods per week. Toggle to Field B using the numeric key pad set the beginning hour then toggle to Field C and set the beginning minute (using 24 hour military time). Toggle to Field D using the numeric key pad set the ending hour then toggle to Field E to set the ending minute (using 24 hour military time). Toggle to Field F use the ◀ or ▶ keys to scroll between the days of the week, choosing which days the shutdown will occur on, use the # key to turn the days on (UPPERCASE) or off (lowercase). Toggle to Field G press the # key to reach screen 2. Field A on screen 2 references Field A on Screen 1 and should not be changed. Toggle to Field H use the # key to turn the shut down period on (Y) or off (N). Toggle to Field I use the # key to set the shutdown type from the available options shown below.

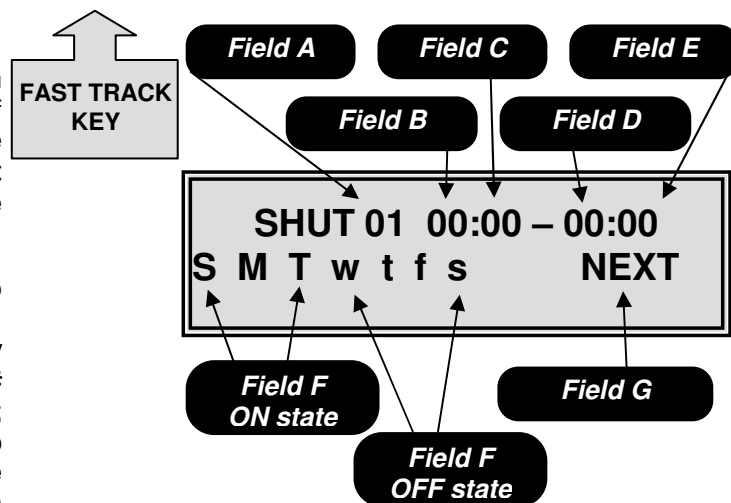

Mode 51 – Timed Shutdown Screen 1

Field A is the shutdown number selection field.
Field B is the shutdown starting hour set field.
Field C is the shutdown starting minute set field.
Field D is the shutdown ending hour set field.
Field E is the shutdown ending minute set field.
Field F is the day of the week selection field. In this example Sunday, Monday and Tuesday are ON and Wednesday, Thursday, Friday and Saturday are OFF.
Field G is the move to the next screen field.

Field I available options

- LIGHTS OFF** – Not available with a 960.
- VEND OFF** – this option disables vending by selection and if all selections are disabled credit acceptance will also be disabled.
- LOW ENERGY** – Not available with a 960.
- TOT SHTDWN** – Not available with a 960.

Toggle to Field J use the numeric key pad to enter the selection number the shutdown applies to, toggle to Field K and use the # key to change the N to Y, then toggle back to Field J and enter the remaining selections. You may use the # key while in Field J to scroll through the previous set selections. Field L may be used to return to Screen 1. To exit this mode, press the **C** key or press the Service Switch.

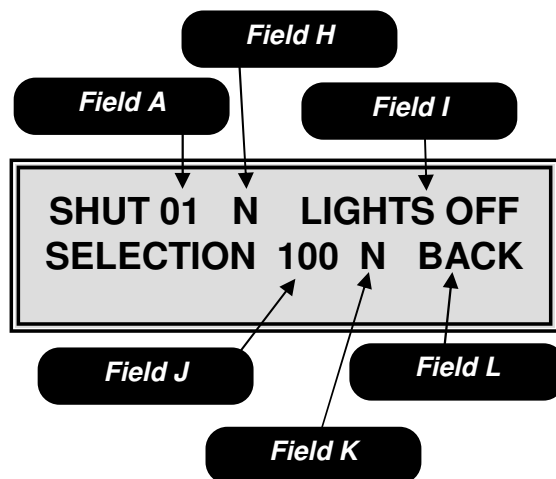

Mode 51 – Timed Shutdown Screen 2

Field A is a reference to Field A on screen 1 and should not be changed.
Field H is the shutdown on/off field.
Field I is the shutdown type field.
Field J is used to select item numbers for the shutdown.
Field K is used to add/remove items from the shutdown.
Field L is used to return to screen 1 in mode 51.

Special Actions

- ◆ The * key can be used as a wildcard in Field J to set entire rows (12*) or the entire machine (1**).



Use of low energy or total shutdown in any machine with perishable product is not allowed.

Programming

Mode 51 – Continued

Note

- ◆ When the shutdown activates and only a portion of the machine is shut down, the display will scroll the message “**SELECTION XXX XXX XXX NOT AVAILABLE**” where XXX are the selections shut down, only 10 selections can be displayed if there are more than 10 a + sign will be added.
- ◆ In the Vend Off mode, if all selections are disabled the display will read “**MACHINE USE NOT ALLOWED UNTIL HH:MM**” where HH:MM is the time the shutdown is scheduled to shut off in Field B.
- ◆ Shutdown times in Field B and C must stay within a 24 hour clock: 00:00 to 23:59.

Mode 52 – Timed Discount

Mode 52 is used to set timed discounts. To access this mode, press **52** on the numeric keypad.

Pressing either the ◀ or ▶ key will allow you to toggle between the fields.

Upon entering the timed discount mode, the display will show the current timed discount settings. Use the # key in Field A to set the discount time period number; this number may be set from 1 to 4 allowing for up to 4 different discount periods per week. Toggle to Field B using the numeric key pad set the beginning hour then toggle to Field C and set the beginning minute (using 24 hour military time). Toggle to Field D using the numeric key pad set the ending hour, then toggle to Field E to set the ending minute (using 24 hour military time). Toggle to Field F, using the ◀ or ▶ keys to scroll between the days of the week, choosing which days the discount will occur on, use the # key to turn the days on (UPPERCASE) and off (lowercase). Toggle to Field G press the # key to reach screen 2. Field A on screen 2 references Field A on Screen 1 and should not be changed. Toggle to Field H use the # key to turn the discount period on (Y) or off (N). Toggle to Field I, and use the numeric key pad to set the discount dollar amount. Toggle to Field J use the numeric key pad to enter the selection number to be discounted, toggle to Field K and use the # key to change the N to Y, then toggle back to Field J and enter the remaining selections. You may use the # key while in Field J to scroll through the previous set selections. Field L may be used to return to Screen 1. To exit this mode, press the C key or press the Service Switch.

Special Actions

- ◆ The * key can be used as a wildcard in Field J to set entire rows (12*) or the entire machine (1**).

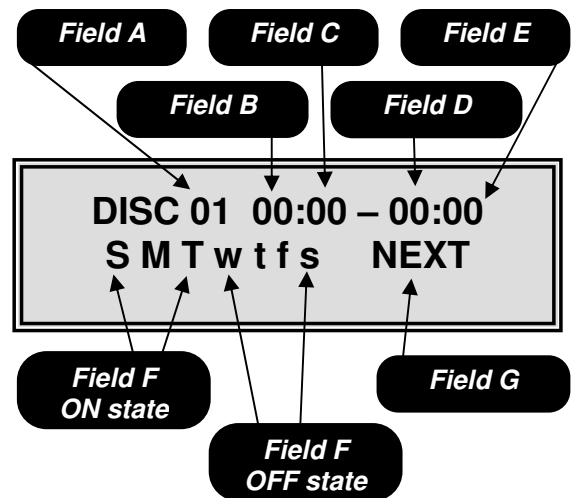

Mode 52- Timed Discount Screen 1

- Field A** is the timed discount number selection field.
- Field B** is the timed discount starting hour set field.
- Field C** is the timed discount starting minute set field
- Field D** is the timed discount ending hour set field.
- Field E** is the timed discount ending minute set field.
- Field F** is the day of the week selection field. In this example Sunday, Monday and Tuesday are ON and Wednesday, Thursday, Friday and Saturday are OFF.
- Field G** is the move to the next screen field

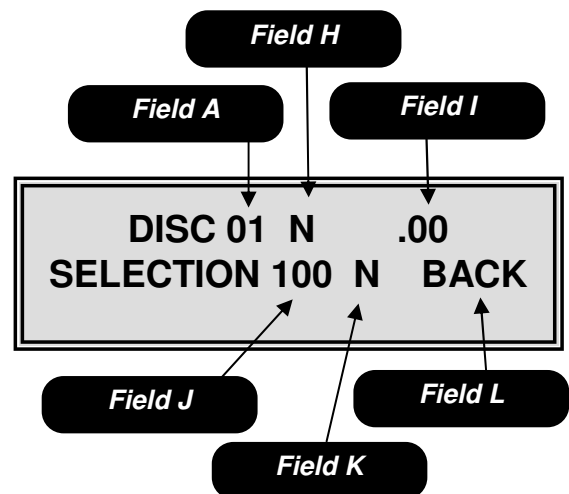

Mode 52 – Timed Discount Screen 2

- Field A** is a reference to Field A on screen 1 and should not be changed.
- Field H** is the timed discount on/off field.
- Field I** is the discount amount field.
- Field J** is used to select item numbers for the timed discount.
- Field K** is used to add additional selection numbers to the timed discount list.
- Field L** is used to return to screen 1 in mode 52.

Programming

Mode 52 – Continued

Note

- ◆ When the discount period becomes active, the display will scroll “SAVE \$.XX ON YYY YYY YYY” where xx is the dollar amount set in Field H and YYY is the items selected in Field I. A maximum of 10 selections will be displayed if more than 10 items a + will be added.
- ◆ Shutdown times in Field B and C must stay with in a 24 hour clock: 00:00 to 23:59.

Mode 53 – Timed Messages

Mode 53 is used to set timed user messages. To access this mode, press **53** on the numeric keypad.

Pressing either the ◀ or ▶ key will allow you to toggle back and forth between the fields.

Upon entering the timed user message mode, the display will show the current timed user message state. Use the # key in Field A to set the timed user message period number; this number may be set from 1 to 5 allowing for up to 5 different timed message periods per week. Toggle to Field B using the numeric key pad set the beginning hour then toggle to Field C and set the beginning minute (using 24 hour military time). Toggle to Field D using the numeric key pad set the ending hour then toggle to Field E and set the ending minute (using 24 hour military time). Toggle to Field F using the ◀ or ▶ keys to scroll between the days of the week, choosing which days the message will occur on, use the # key to turn on (UPPERCASE) or of (lowercase) the desired days. To exit this mode, press the **C** key or press the Service Switch.

Note

- ◆ The times in Field B and C must stay with in a 24 hour clock (00:00 to 23:59).
- ◆ A user message must be set in Mode 60 before a timed message can be set. If no user messages are set, the default user message described in Mode 60 will be displayed.

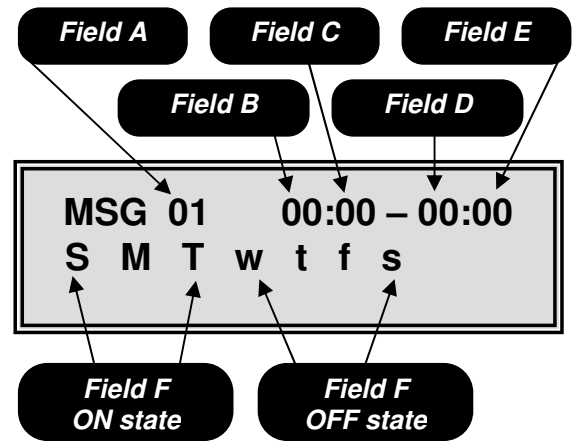

Mode 53 – Timed Messages

Field A is the message select field.

Field B is the starting hour in 24 hour military time.

Field C is the starting minute in 24 hour military time.

Field D is the ending hour in 24 hour military time.

Field E is the ending minute in 24 hour military time.

Field F is the day selection field. In this example Sunday, Monday and Tuesday are on and Wednesday, Thursday, Friday and Saturday are off.

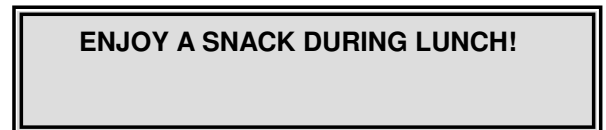

One Possible Timed Message

Programming

Mode 60 – User Message

Mode 60 is used to set a user message. To access this mode, press the **Set Messages Fast Track Key** or press **60** on the numeric keypad.

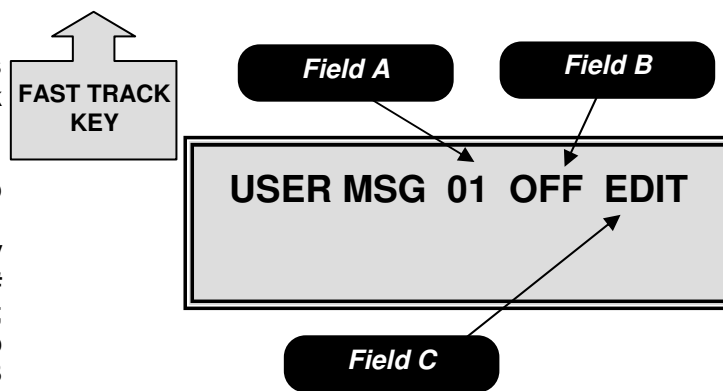

Pressing either the ◀ or ▶ key will allow you to toggle back and forth between the fields.

Upon entering the user message mode, the display will show the current user message state. Use the # key in Field A to select the user message number; this number may be set from 1 to 4 allowing for up to 4 programmable user messages. Toggle to Field B to select which line your message will be displayed on. Use the # key to choose from one of the available options shown below.

Field B available options

- 1** – Your message will be displayed on the top line of the display.
- 2** – Your message will be displayed on the bottom line of the display.
- OFF** – Your message will not be displayed.

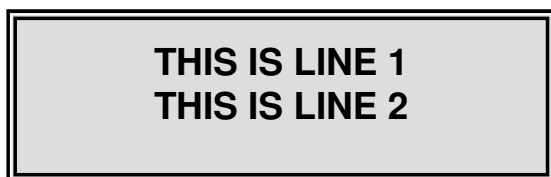

Toggle to Field C use the # key to enter the editing screen. Upon entering the edit screen the cursor will be flashing Field D. Field E is the edit instruction field use the keys shown, see below for additional information. When done editing press the # to save the message to memory. To exit this mode, press the **C** key or press the Service Switch.

Edit Keys

- KEY 1** = to scroll up through the available characters.
- KEY 2** = to scroll down through the available characters.
- KEY 4** = will insert a duplicate of the currently selected character (flashing) and shift all characters to the right by one.
- KEY 5** = will delete the currently selected (flashing) character and shift all characters to the left by one.
- KEY 6** = will insert a flashing blank space to the left of the currently selected (flashing) character and shift all characters to the right by one.

Note

- ◆ User message numbers 1 thru 4 are user programmable and each can be 100 characters in length.
- ◆ User message number 5 is the time and date message. This message cannot be changed.

Mode 60 – User Message Screen 1

Field A is the user message select field.
Field B is the display location selection field.
Field C is the enter edit screen field.

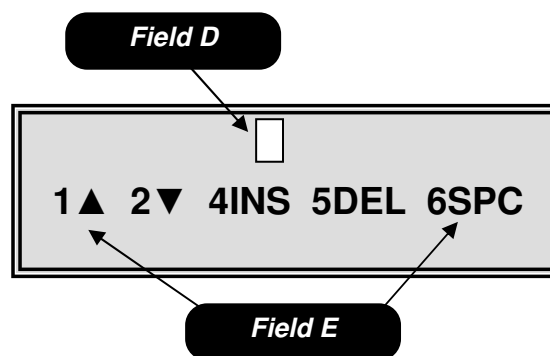

Mode 60 – User Messages Screen 2

Field D represents the flashing cursor this is the position where characters will be added or deleted.
Field E is the editing instruction field.

Number	Message
01	HAVE A NICE DAY
02	HAVE A GREAT DAY
03	HAVE A GREAT DAY
04	Have a nice day
05	Current time/date setting
06	HAVE A NICE DAY

Default User Messages

- ◆ The } character can be used as an end of message character in any text message greater than 10 characters in length.

Programming

Mode 60 – Continued

- ◆ User message number 6 is the factory default message. This message cannot be changed.
- ◆ If more than 1 user message is programmed for the same line, the message with the higher number will be displayed.
- ◆ When line 2 is not assigned to any message, it will show the message Credit .00, amount of deposited coins.

◆ Choosing one of the graphic messages (7 through 14) in either line 1 or 2 will override any lower number message assigned.

◆ To save time scrolling through the available letters, insert an M then use the 4 key to insert several duplicate M's. This will give you a starting point in the middle of the alphabet.

Program #	Message	Image
#7	Hungry? Grab a snack and stay on track!	Scrolling train
#8	ENERGY to keep you on the run.	People running
#9	Guaranteed to deliver or your money back.	Golden Eye logo
#10	SNACK ATTACK	Shark scene
#11	Grand Central Energy Station – Refueling in progress!	Scrolling train
#12	Have no fear – satisfaction's served here! Guaranteed to deliver or your money back.	Superhero
#13	Have a great day!	Smiling faces
#14	Smart choices SERVED HERE!	

130 Series Graphic Display Pre-programmed Messages.



Programming

Mode 61 – After Sale Message

Mode 61 is used to customize the message that appears after each vend. To access this mode, press **61** on the numeric keypad.

Pressing either the ◀ or ▶ key will allow you to scroll through the current message.

Upon entering the after sale message mode, the display will show the current message along with a flashing character in Field A. Field B is the edit instruction field, use the keys shown, see below for additional information. When done editing press the # key to save the message to memory. To exit this mode, press the **C** key or press the Service Switch.

Edit Keys

KEY 1 = to scroll up through the available characters.

KEY 2 = to scroll down through the available characters.

KEY 4 = will insert a duplicate of the currently selected character (flashing) and shift all characters to the right by one.

KEY 5 = will delete the currently selected (flashing) character and shift all characters to the left by one.

KEY 6 = will insert a flashing blank space to the left of the currently selected (flashing) character and shift all characters to the right by one.

Note

- ◆ The after sale message may contain up to 80 additional characters.
- ◆ The after sale message will be appended for food/frozen machines with “PRESS COIN RETURN TO REOPEN DOOR”

Mode 62 – Out of Service

Mode 62 is used to add additional information to the Out of Service message to aid your customers in the event a machine is out of order. To access this mode, press **62** on the numeric keypad.

Pressing either the ◀ or ▶ key will allow you to scroll through the current message.

Upon entering the out of service message mode, the display will show the current out of service message along with a flashing character in Field A. Field B is the edit instruction field. Use the keys shown, see below for additional information. When done editing press the # key to save the message to memory. To exit this mode, press the **C** key or press the Service Switch.

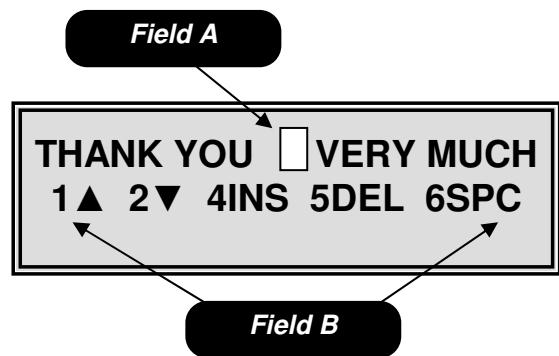

Mode 61 – After Sale Message

Field A represents the flashing cursor this is the position where characters will be added or deleted.

Field B is the editing instruction field.



Default After Sale Message



One Possible After Sale Message

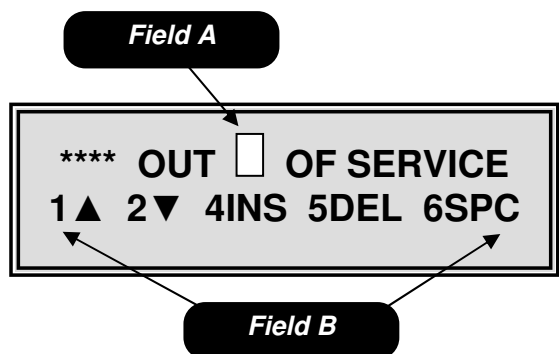

Mode 62 – Out of Service

Field A represents the flashing cursor this is the position where characters will be added or deleted.

Field B is the editing instruction field.

Programming

Mode 62 – Continued

Edit Keys

KEY 1 = to scroll up through the available characters.

KEY 2 = to scroll down through the available characters.

KEY 4 = will insert a duplicate of the currently selected character (flashing) and shift all characters to the right by one.

KEY 5 = will delete the currently selected (flashing) character and shift all characters to the left by one.

KEY 6 = will insert a flashing blank space to the left of the currently selected (flashing) character and shift all characters to the right by one.

Note

- ◆ The out of service message may contain up to 80 additional characters.
- ◆ The out of service message will only be displayed if the entire machine is out of service or if no motors or cabinets are available.

Mode 63 – Alternate Language

Mode 63 is used to set an alternate language. To access this mode, press **63** on the numeric keypad.

Upon entering the alternate language mode, the display will show the alternate language state. Press the **#** key to toggle between on and off. With the alternate language mode turned on all messages will be displayed in the alternate programmed language. To exit this mode, press the **C** key or press the Service Switch.

Mode 80 – Test Vend

Mode 80 is used test vend the machine. To access this mode, press the **Test Vend Fast Track Key** or press **80** on the numeric keypad.

Upon entering the test vend mode the display will show select. Use the numeric key pad to enter the selection in Field A (this field will be blank until a numeric key is pressed). If the selection motor tests ok the display will read “TEST PASSED” in Field B, if the motor failed the display will read “MTR ERROR” in Field B. To exit this mode, press the **C** key or press the Service Switch.



Default Out of Service Message



One Possible Out of Service Message



Mode 63 – Alternate Language
Field A is the on/off field.

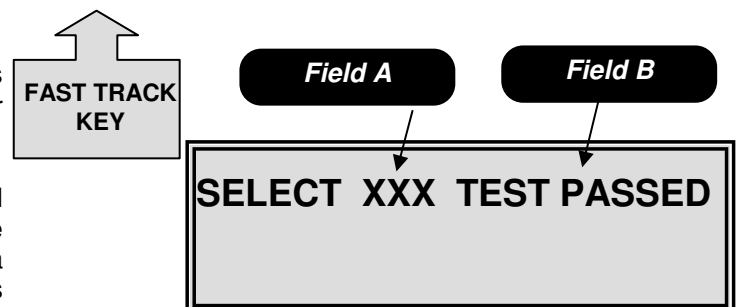

Mode 80 – Test Vend
Field A is the item selection field. This field will be blank until a numeric key is pressed.
Field B is the pass/fail field. If the motor passed it will read TEST PASSED if the motor failed it will read MTR ERROR.

Programming

Mode 81 – Sequential Event Log

Mode 81 is used to view the sequential event log. In this mode you are able to review the last 25 events that took place in the machine. To access this mode, press the **Event Log Fast Track Key** or press **81** on the numeric keypad.

Upon entering the sequential event log, the display will show the last event that took place in the machine. Field A is the sequential event number. Field B is the event that took place (for an explanation of the abbreviation see table 7). Field C shows the selection number the event corresponds to (if applicable). Field D shows the date of the event. Field E shows the time of the event. Use the ◀ key to scroll through the previous sequential events (maximum of 25). Press # then the * key to clear the sequential event log. To exit this mode, press the **C** key or press the Service Switch.

◆ **The chime will sound 3 times when there are no more items to display.**

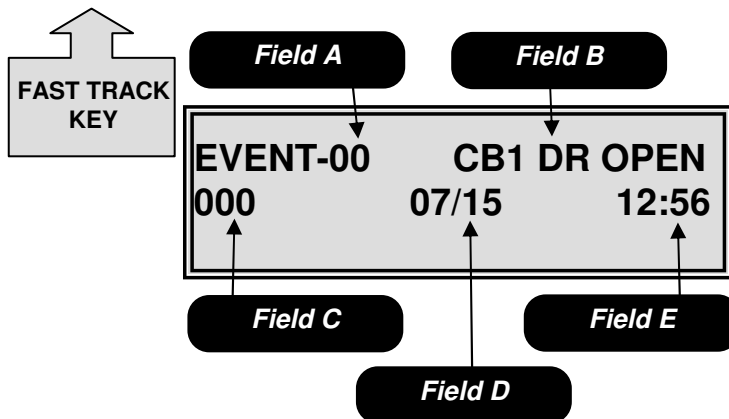

Mode 81 – Sequential Event Log

Field A is the sequential event number.
Field B is the event name.
Field C is the selection number the event corresponds to if applicable.
Field D is the date of the event.
Field E is the time of the event.

DISPLAY	EVENT
CAB1 DR OPEN	Cabinet 1 Door Open
CAB1 DR CLS	Cabinet 1 Door Closed
CAB2 DR OPEN	Cabinet 2 Door Open
CAB2 DR CLS	Cabinet 2 Door Closed
PWR UP	Power UP
MTR XYZ	Run Motor XYZ
GE TRIG	Golden Eye Triggered
DEX	Machine Dexed
BAF OPEN	Baffle Door Open
BAF CLSD	Baffle Door Closed
EVNT CLEAR	Event Log Cleared
ERROR CLEAR	Error Log Cleared
MOTOR ERROR	Motor Error
PRICE SET	Price Set
TIME/DATE SET	Time Date Set
RESET ACCOUNT	Reset Accountability
HEALTH ERROR	Health Error
COMM ERROR	Communication Error
C1 DEFROST	Cabinet 1 Defrost
C2 DEFROST	Cabinet 2 Defrost

Table 7: Event list.

Programming

Mode 82 – Service History

Mode 82 is used to view the service history. To access this mode, press the **Service Log Fast Track Key** or press **82** on the numeric keypad.

Upon entering the service history mode, the display will show a service event in Field A. Field B shows you the duration time of the event if applicable; Field B may also show the selection number if applicable to the event in Field A. Field C shows you the time of the event. Field D shows the date of the event. Pressing either the ► key allows you to scroll through the service history events. To exit this mode, press the **C** key or press the Service Switch.

The service history events will be displayed in the following order.

1. The last 5 Cabinet 1 Door Openings, starting with the most recent.
2. The last 5 Cabinet 2 Door Openings, starting with the most recent.
3. The last 5 Motor Errors, starting with the most recent.
4. The last 5 Product Fall Errors, starting with the most recent.
5. The last 5 Health Errors.
6. The last 5 MIS Resets.
7. The last 5 Time/Date sets.
8. The last 5 Price Settings.
9. The last 5 Power Outages.
10. The last 5 Defrost Events.

◆ **The chime will sound 3 times when there are no more items to display.**

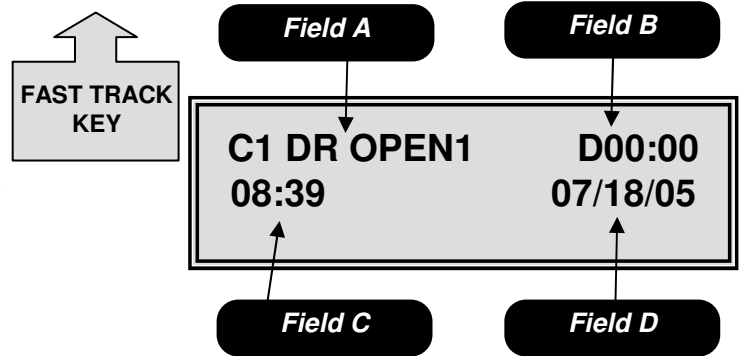

Mode 82 – Service History

Field A is the event field.

Field B is the duration or selection field.

Field C is the time field.

Field D is date field.

Programming

Mode 83 – Temperature Log

Mode 83 is used to view the temperature log. To access this mode, press the **Temp Log Fast Track Key** or press **83** on the numeric keypad.

Upon entering the temperature log mode, the display will show the current temperature. Field A shows the cabinet and zone the data is referencing (in this example C1L is the lower zone of a chilled machine). Field B is the total minutes since the temperature was last taken. Field C shows the temperature. Field D shows the status of the refrigeration unit at the time the temperature was recorded. See the list below for the available options for Field D.

Available Options

- R** – Refrigeration was on.
- D** – Defrost was on.
- O** – Refrigeration was off.

Use the ◀ key to view the previous temperature samples which have been taken in 1 minute intervals. When the last sample is reached the display will show ‘NO MORE TEMPS’ in the first line and Field E will scroll the message “TO CLEAR TEMPS PUSH # THEN * TO RUN REFRIDGERATION TEST PUSH 1”. To clear the temperature log press # then *. To run the refrigeration test push the **1** key. The display will change to “REF TEST ACTIVE”. Upon completion of the test the display will show either

“REFER TEST PASS” or “REFER TEST FAIL”. To exit this mode, press the **C** key or press the Service Switch.

◆ **The chime will sound 3 times when there are no more items to display.**

Mode 84 – Baffle Door Test

Mode 84 is used to test the baffle doors. To access this mode, press **84** on the numeric keypad.

In Field A use the # key to select which cabinet to perform the baffle test on. Press the **0** key to open the baffle door shown in Field B. Press the * key to close the baffle door shown in Field C. To exit this mode, press the **C** key or press the Service Switch.

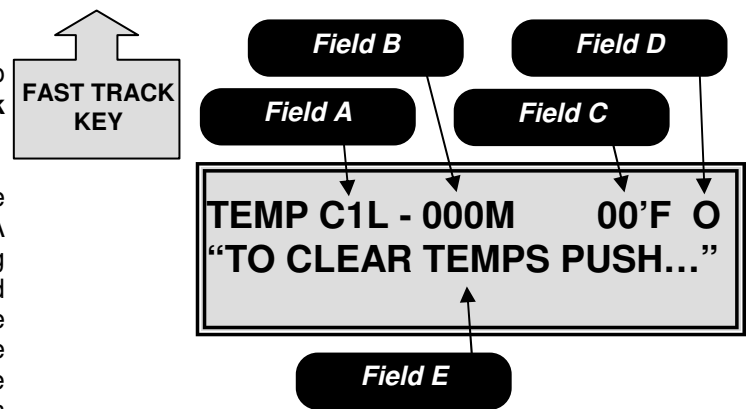

Mode 83 – Temperature Log

Field A is the cabinet and zone indicator.

Field B is the total minutes since the temperature was last taken.

Field C is the temperature.

Field D is the status of the refrigeration unit at the time the temperature was recorded.

Field E is the scrolling instruction field.

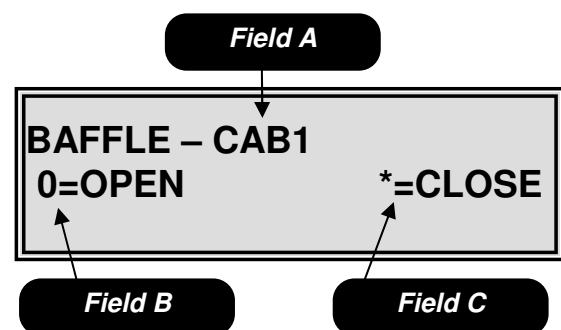

Mode 84 – Baffle Door Test

Field A is the cabinet selection field.

Field B is the open baffle door key.

Field C is the close baffle door key.

Programming

Mode 85300 – Set Serial Number

Mode 85300 is used to set a serial number for retrieval during a print out or in the DEX data information. To access this mode, press **85300** on the numeric keypad.

Upon entering the set serial number mode, the display will show the current set serial number. Use the numeric key pad to set a serial number (up to 17 characters in length). When done editing, press **#** to save the number to memory. To exit this mode, press the **C** key or press the Service Switch.

◆ This field appears in a DEX file as ID101

Mode 86200 – Set Machine ID

Mode 86200 is used to set a serial number for retrieval during a print out or in the DEX data information. To access this mode, press **86200** on the numeric keypad.

Upon entering the set machine ID mode, the display will show the machine ID number that is currently set. Use the numeric key pad to set a machine ID number up to 20 characters in length. When done editing, press the **#** to save the number to memory. To exit this mode, press the **C** key or press the Service Switch.

◆ This field appears in a DEX file as ID102

Mode 87400 – Set Location ID

Mode 87400 is used to set a location ID number for retrieval during a print out or in the DEX data information. To access this mode, press **87400** on the numeric keypad.

Upon entering the location ID mode, the display will show the current location ID number. Use the numeric key pad to set a location ID number up to 20 characters in length. When done editing, press the **#** to save the number to memory. To exit this mode, press the **C** key or press the Service Switch.

◆ This field appears in a DEX file as ID104

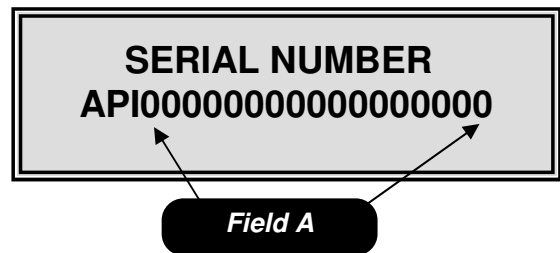

Mode 85300 – Set Serial Number
Field A is the serial number set field.

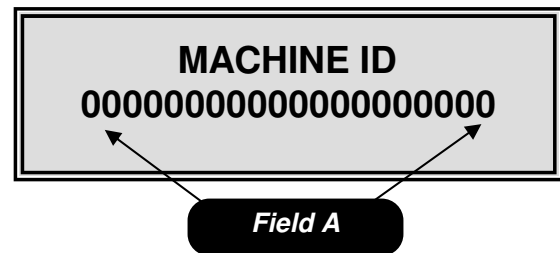

Mode 86200 – Set Machine ID
Field A is the machine ID number set field.

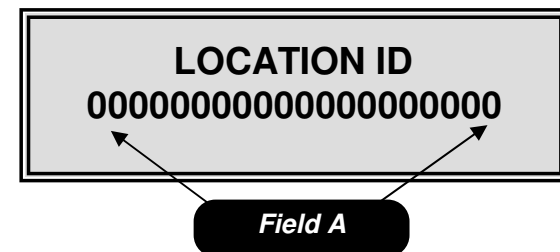

Mode 87400 – Set Location ID
Field A is the location ID number set field.

Programming

Mode 88123456790 – Factory Test

Mode 88123456790 is used to run a factory test. To access this mode, press **88123456790** on the numeric keypad.

After entering the factory test mode, the machine will automatically test the first vend motor, you must than press the **#** key to advance to the next motor to be tested. If a vend motor is not present or is bad, the test will stop and the display will flash in Field B one of the following: MISSING, OVER CURRENT or TIMEOUT. To continue with the test press the **#** key. Once the test is complete all options and prices will be reset to factory defaults.

◆ **Using this mode on a machine full of product will cause one of each item to vend.**

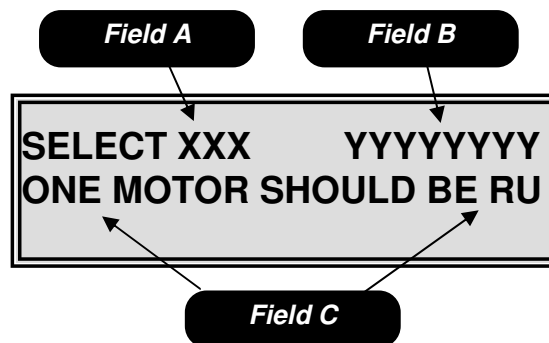

Mode 88123456790 – Factory Test

Field A is the vend motor that is being tested.

Field B is the test information field.

Field C is the scrolling information field.

Parts

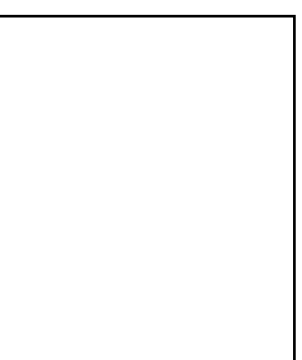
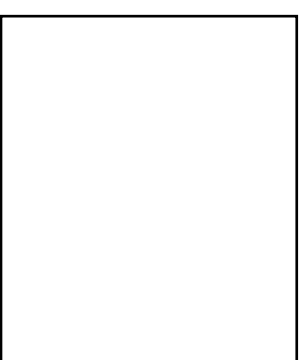
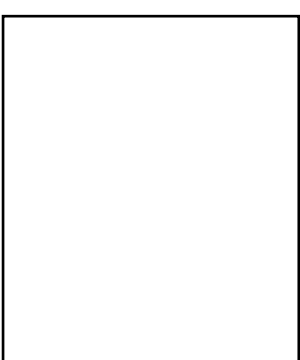
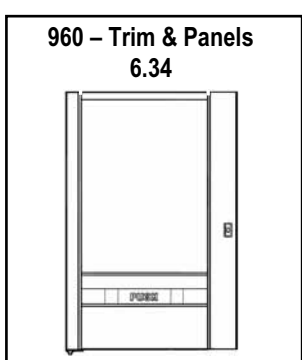
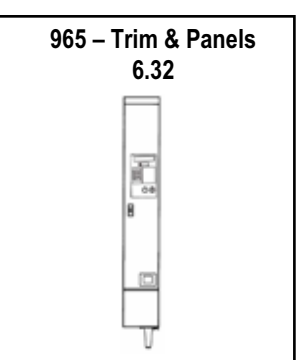
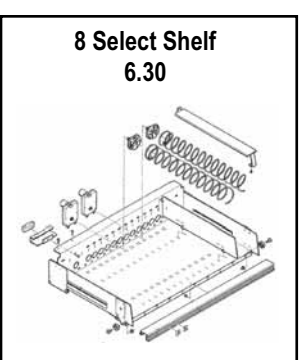
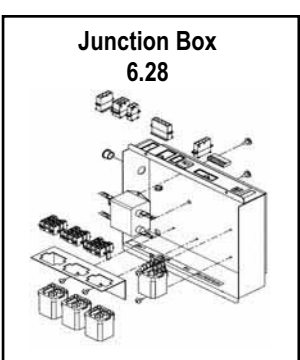
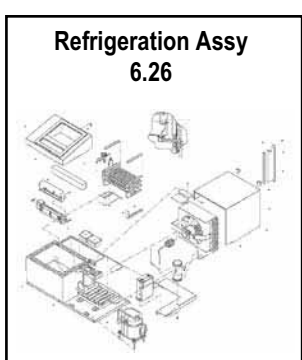
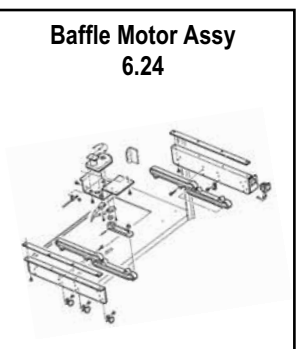
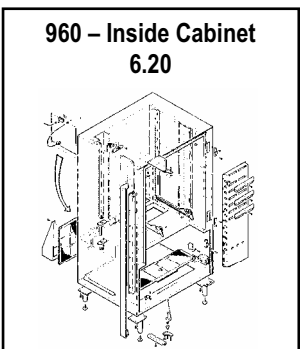
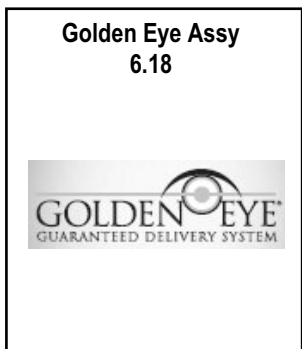
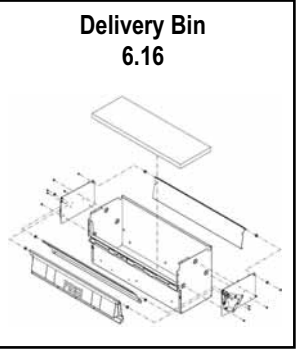
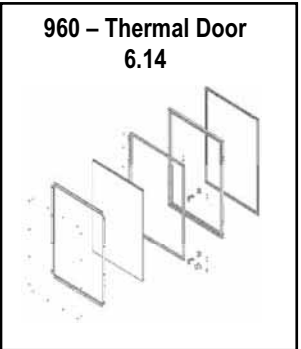
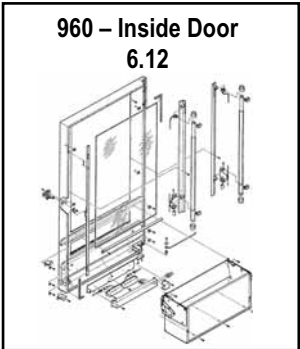
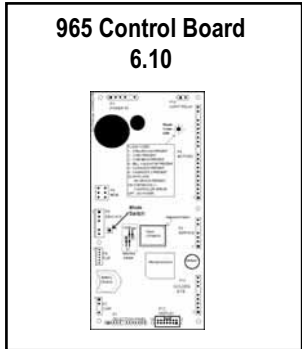
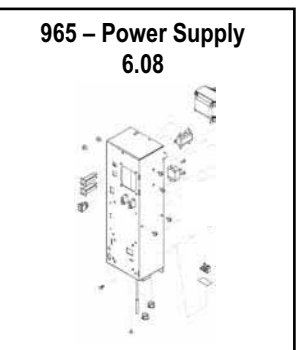
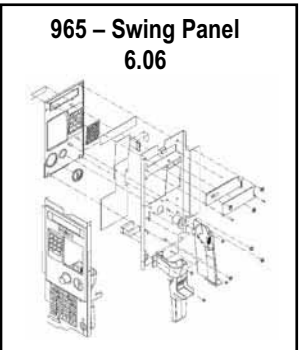
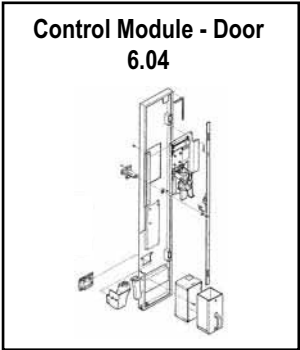
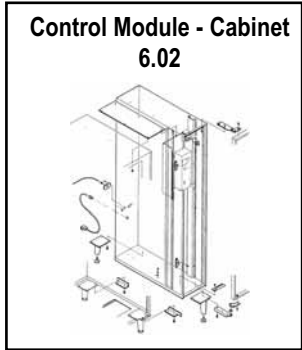

965 / Control Module Cabinet

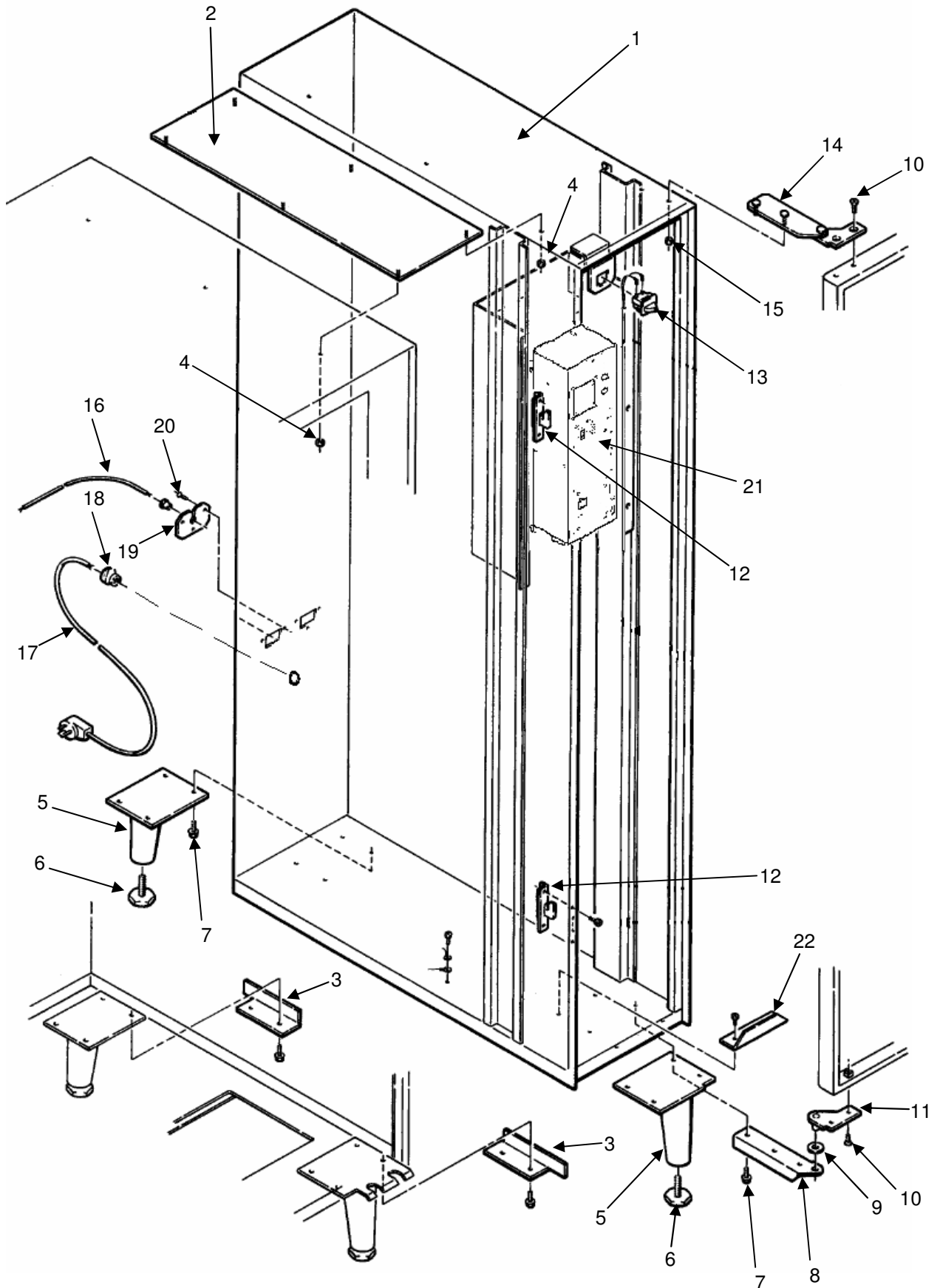

965 / Control Module Cabinet

Key	Description	Part No.
1	Cabinet, Control Module, Weldment, Specify Color	600785
2	Plate, Mounting, Top, Control Module	600744
3	Bracket, Mounting, Bottom, Control Module	202762
4	Control Module Mounting Hardware	660608
5	Leg, Front and Rear, Control Module	600195
6	Leveler, Leg	300103
7	Screw, 5/16-18 x 3/4, Hex Head	420187
8	Hinge Plate, Lower	12000033
9	Washer, 1.00 OD, .515 ID, .03	420010-23
10	Screw, 1/4-20 x 1/2, Torx Tap	13100035
11	Pivot Plate, Lower Assembly	600742
12	Catch, Door Lock	12000290-01
13	Door Switch and Harness Assembly	660666
	Door Switch, Only	380258
	Harness, Door Switch	680632
14	Upper Hinge Assembly	600740
15	Nut, 1/4 x 20 Keps, ZN	438-41
16	Communication Cable Assembly, w/Golden Eye	16600324
17	Line Cord, 117 V, Domestic	9339001
	<i>Line Cord, 120 V, Export</i>	<i>680459</i>
	<i>Line Cord, Europe</i>	<i>680501-1</i>
	<i>Line Cord, Australia</i>	<i>380275-1</i>
	<i>Line Cord, Israel</i>	<i>680544-1</i>
	<i>Line Cord, UK</i>	<i>680578-1</i>
	<i>Line Cord, India</i>	<i>16800043</i>
18	Strain Relief Bushing	380052-2
19	Bracket, Strain Relief	202442
	Cover, Strain Relief, (Blocking Plate) Not Shown	202442-1
20	Screw, 8-32 x 3/8, Pan Head, Self Tap	276-8R6
21	Junction Box (See Page 6.08)	
22	Cash Box Stop	202553
NS	Base Kit (Kick Plate) Not Shown	660146-14
NOTE: Items highlighted in <i>Bold Italics</i> are used in export models only.		

965 / Control Module Door

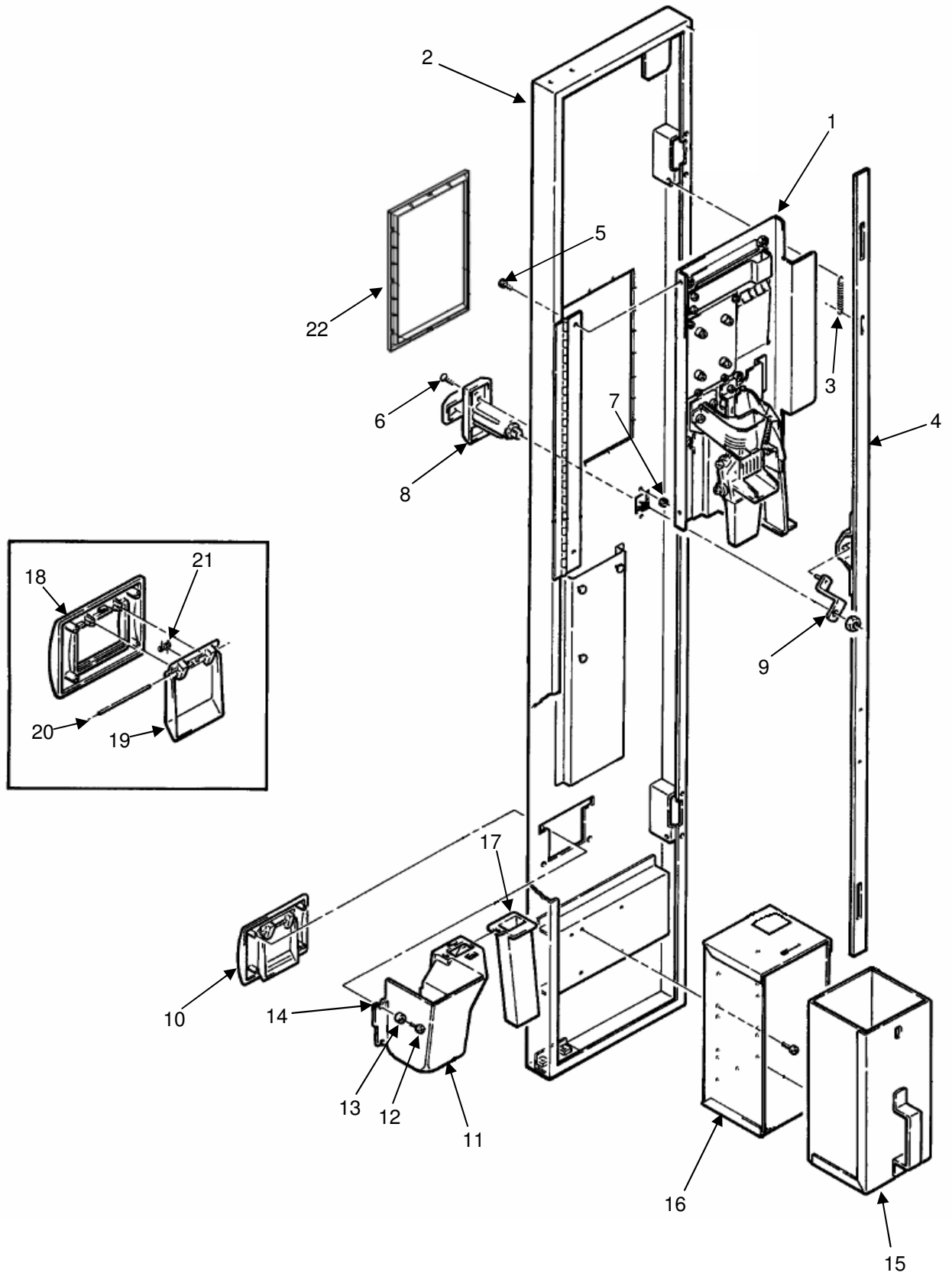

965 / Control Module Door

Key	Description	Part No.
1	Swing Panel Assembly, Complete For Detail Parts see Page 6.06	16600433
2	Door Weld Only, 3rd Payment	9652006
3	Spring, Lock Bar	400112
4	Locking Bar	16000102
5	Screw, 8-32 x 3/8, Pan Head, Self Tap	276-8R6
6	Bolt, Carriage 10-24 x 3/4	118-10-12
7	Nut, Hex 8-32	404-8
8	T-Handle Assembly – Black Paint	17200002-02
9	Lock Arm Assembly	600739
10	Bezel Assembly, Coin Cup, Black Includes Items 19, 20, 21 and 22	16600403
11	Coin Cup Asm	440413
	Coin Cup Asm, Security (optional)	16600170
12	Screw, #8 x 3/8 Phillips Pan Head, Plastite	305-8R6
13	Ferrule, Cup Washer	420144
14	Washer, 9/16 Od .328 Id .032thk	420010-17
15	Cash Box, Plastic	14400047
16	Bracket, Cash Box Mounting	16600150
17	Chute, Cash Box	440414
18	Bezel Only, Coin Cup, Black	14400106
19	Door, Coin Cup	440412
20	Pin Pivot, Coin Cup Door	300212
21	Spring, Coin Cup Door	400108
22	Trim Ring, Black	440444-2

965 / Swing Panel

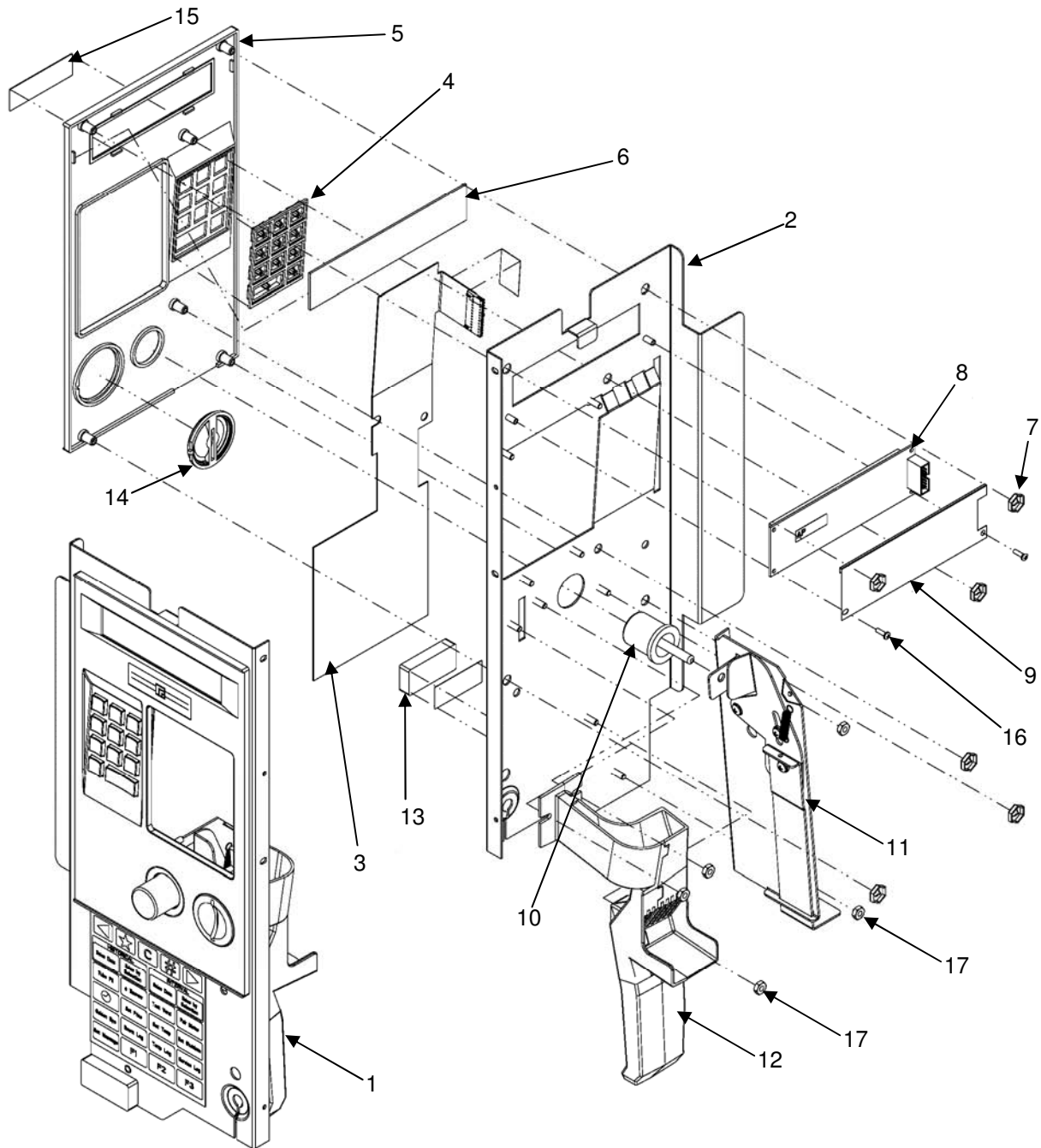

965 / Swing Panel

Key	Description	Part No.
1	Swing Panel Assembly Complete	16600433
2	Swing Panel Riveted Assembly	16400087
3	Selection Switch, English/Spanish	13800002-01
4	Keypad, Dk Gray, with Braille	14400015-01
5	Selector Bezel, Black	440442
6	Display Window	14400112
7	Pal Nut, ¼ Self Threading	18443
8	Display	13600018
9	Insulator, Display Board	14400062
10	Button, Coin Return, Euro Gray	440289-5
11	Coin Return Assembly	9655001
12	Chute, Coin Entry, Long	16600438
13	Magnet, Swing Panel	420400
14	Coin Insert (USA, El Salvador, Ethiopia, Tahiti)	440445-5
	<i>Coin Insert (Chile, Brazil, France, Germany, Taiwan)</i>	440445-6
	<i>Coin Insert (UK, Turkey, Panama, Columbia, China, Peru, Sweden, South Africa, Saudi Arabia)</i>	440445-7
	<i>Coin Insert (Australia, New Zealand, Italy, Lebanon, Mexico, Holland, Israel, Malaysia, Tunisia, Singapore, Oman, Uruguay, Denmark, Philippines, United Arab Emirate)</i>	440445-9
	Coin Insert - No Slot	440445-11
15	AP Logo Plate	17400209
16	Screw, 4-40 x 3/8 Pan head Mach	116-4R6
17	Nut, 8-32 Keps Nut ZN	438-8
NS	Validator Blocking Plate	660580
NS	Bracket No Coin	12000809
NOTE: Items highlighted in <i>Bold Italics</i> are used in export models only.		

965 / Power Supply Box

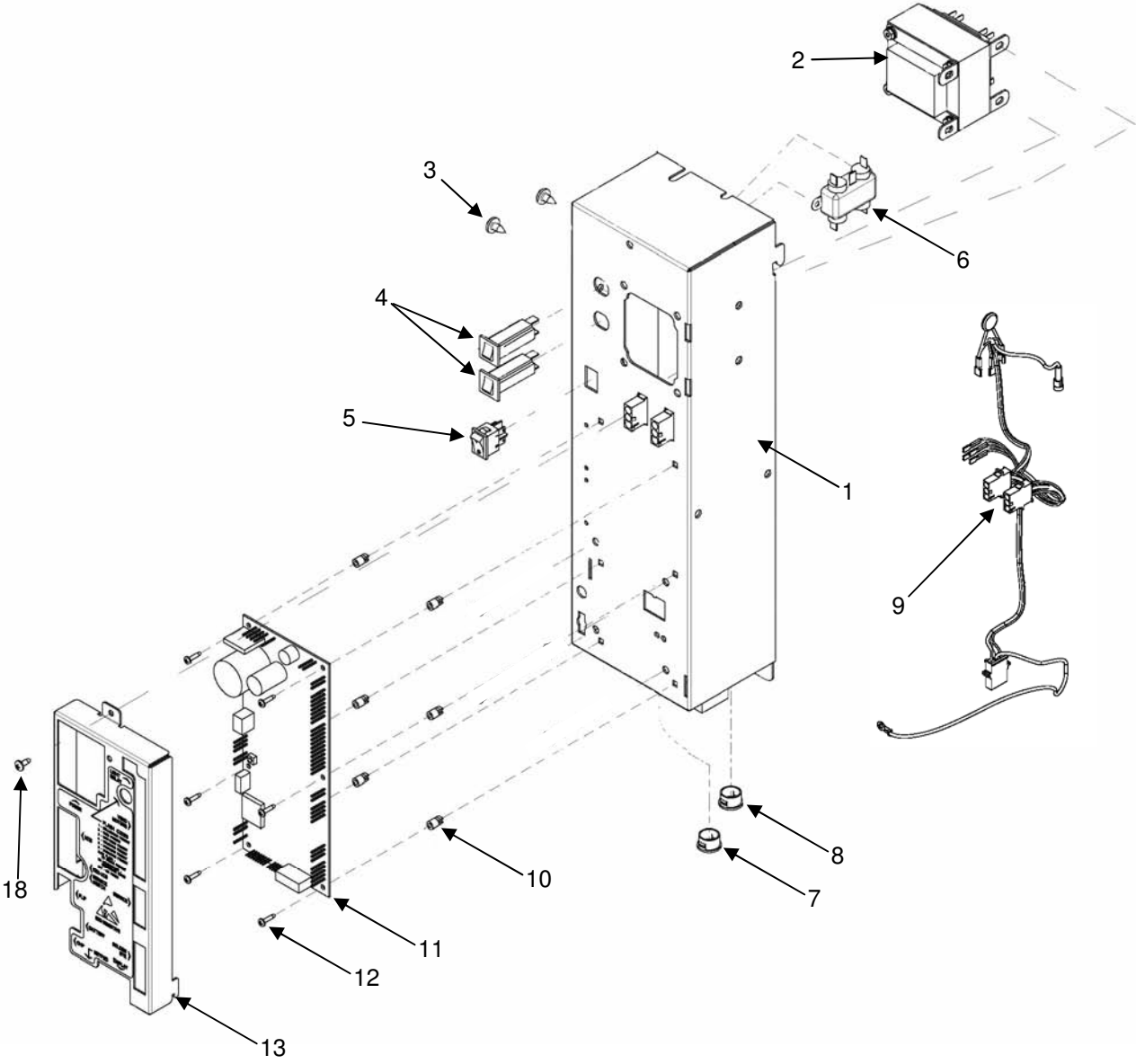

965 / Power Supply Box

Key	Description	Part No.
1	Power Box assembly	16600435
	Junction Box Weldment ST/130	12000800
2	Transformer 120v/230v ST	13900003
3	Scr Pn/Nibs Hd Type Ab 1/4x1/2	216-41R8
4	Circuit Breaker 3 Amp	380241
5	Switch Rocker	380243
6	Filter-Light	380303
7	Dome Plug 5/8 Hole	420040-1
8	Snap Bushing 5/8 Hole	420040-2
9	Harness Junction Box	16800131
10	Standoff Circuit Board 1/4"	17100003
11	Control Board See Page 6.10	13600024
12	8-32x3/8 Pn/Nibs Hd T23 BI Max	276-8R6
17	Control Board Cover Assy	16600386
18	Screw, #6 x 12, Pan Head	218-6R8
NS	Nut, 8-32 Keps	438-8
19*	Harness DEX/UCS Chassis Mount	16800044
20*	Harness Touch Memory	16800013
*	Optional items (Not Shown)	

965 / Control Board

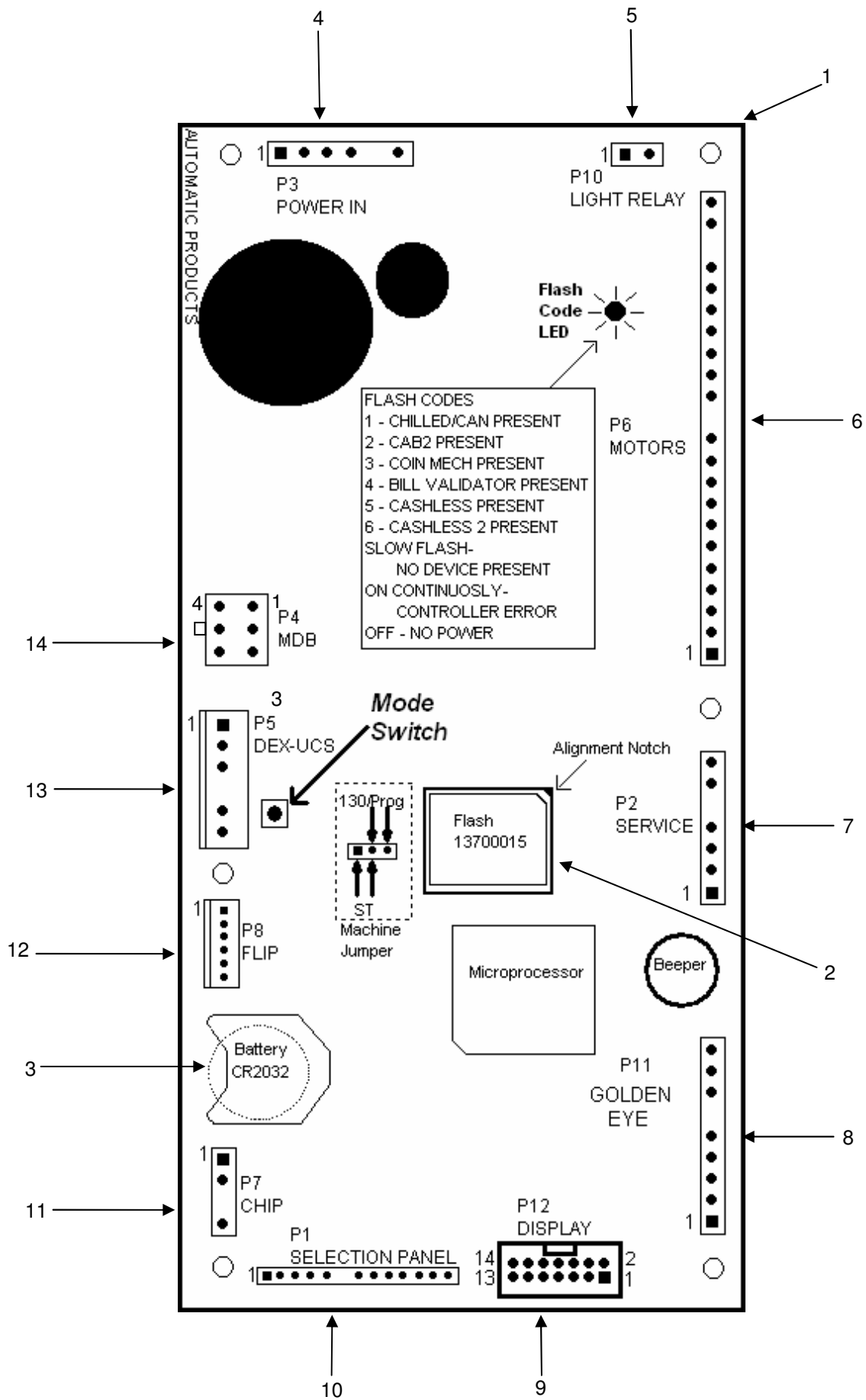

965 / Control Board

Key	Description	Part No.
1	Control Board.	13600024
2	Flash Memory Chip.	13700015
3	Battery CR2032, 3 Volt (available locally).	17100007
4	Power Box Harness	See page 6.08
5	Power Box Harness	See page 6.08
6		
7	Door Switch Harness	680632
8	Harness, Golden Eye	16800147
9	Display/Keypad/Harness, Assembly Complete.	16800148-01
10	Display/Keypad/Harness, Assembly Complete.	16800148-01
11	Touch Memory Harness	16800013
12		
13	DEX/UCS Harness Assembly, Chassis Mount.	16800044
14	Communication Cable, Assembly Complete	16600324

960 / Inside Door

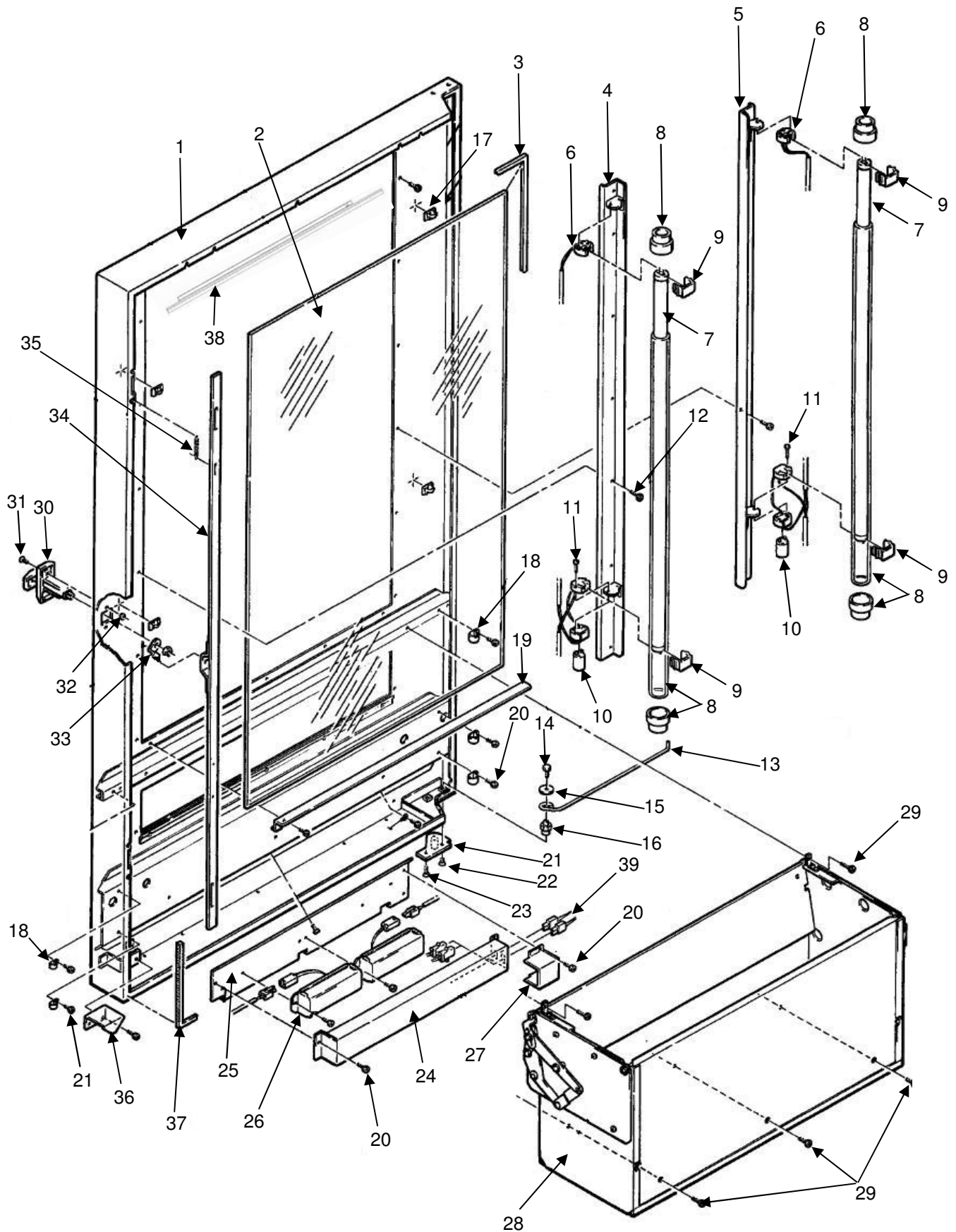

960 / Inside Door

Key	Description	Part No.
1	Door Weldment Only, Square.	16000323
2	Front Window, (44-5/8 X 26-7/8 X 1/8) NOTE: Replacement Glass Must Be Hard Tempered or Lexan Only	750141
3	Window Edging (Order Per Inches) 143 total	460436
4	Window Clamp And Light Assembly Complete, Lock Sid Window Clamp Only, Lock Side	660612-1 600750-1
5	Window Clamp And Light Assembly Complete, Hinge Side Window Clamp Only, Hinge Side.	660612 600750
6	Florescent Lamp Harness	680607
7	Florescent Lamp (F30T8/CW)	380022-6
8	Light Bulb Guard	420398
9	Cover, Florescent Light End	440423
10	Starter (FS 4) Starter (FS 11) 230V	380023-2 380023-4
11	4-36 X 3/4 Screw, Round Head	420062-1
12	6-18 X 11/16 Screw, Round Head	201-6R11
13	Door Stop Rod	400193
14	1/4-20 X 1/2 Bolt, Hex Head	114-41-8
15	Washer	420010-10
16	Door Stop Anchor	300156
17	Wire Clamp, Adhesive Back	420051
18	Cable Clamp, Nylon	420035
19	Lower Window Clamp	202604
20	8-32 X 3/8 Nibs Head	276-8R6
21	Lower Door Hinge Plate Assembly	640157
22	Screw, 1/4-20X1 FI Torx	13100035-01
23	Screw, 1/4-20X1/2 FI Torx	13100035
24	Cover, Ballast Assembly	202576
25	Mounting Bracket, Ballast.	12000447
26	Ballast Assembly Complete, 117 V includes items 24, 25 & 26A Ballast Assembly Complete, 230 V, includes items 24, 25 & 26A	16600305 16600306
26A	Ballast Only, 117 V Ballast Only, 230 V	380315 380314
27	Cover, Ballast Plugs	202577
28	Delivery Bin, See Page 6.16 For Detailed Parts List	16600490
29	Delivery Bin Mounting Screw	276-8R6
30	T Handle, 1/4 Turn, with nut, Painted Black	17200003-02
31	Bolt, 10-24 X 3/4 Carriage	118-10-12
32	#10-24 Hex Nut.	404-10
33	T Handle Lock Arm	640216
NOTE: Items highlighted in Bold Italics are used in export models only.		

Key	Description	Part No.
34	Locking Bar	16000103
35	Spring, Lock Bar	400112
36	Striker, Power Interlock Switch.	660618
37	1/4 X 1/4 Gasket, Foam.	460041
38	Bracket, Top Window	12000741
39	Harness, Light to Cabinet	680658
NS	Duct for Light Harness	14400013
NS	Duct Cover	14400014
NS	Decal, Select Here with Arrow	17400085

960 / Thermal Door

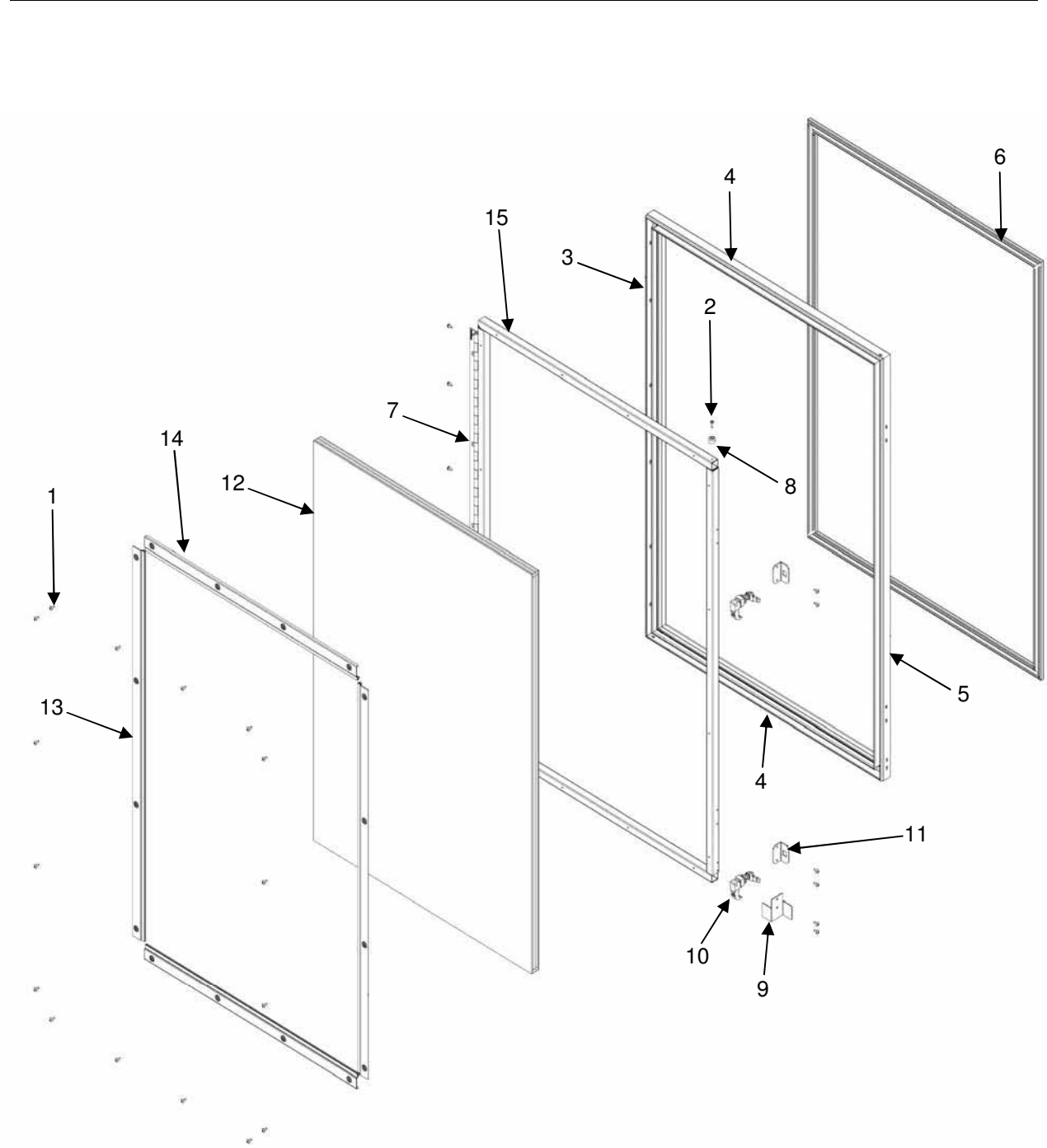

960 / Thermal Door

Key	Description	Part No.
	Assembly Complete, Thermal Window 117 V	17500006
	<i>Assembly Complete, Thermal Window 230 V.</i>	<i>17500006-01</i>
1	Screw #8 x 1/2 PH TR/Nibs Hd Zn & Wax	210-8R8
2	8 x 5/8 PH Pan HD Type B ZN & Wax	217-8R10
3	Extrusion, Window Retainer, Hinge Side	440429
4	Extrusion, Window Retainer, Top & Bottom	440429-1
5	Extrusion, Window Retainer, Lock Side	440129-2
6	Door Gasket	460686
7	Hinge	460703
8	Rubber Bumper	13100004
9	Thermal Door Switch Plate	12000116
10	Thermal Window Latch Assy, without Bracket	13100003
	Door Lock Latch Bracket Only	201424-1
11	Thermal Window Latch Bracket	12000145
12	Thermal Glass, 117 V, 100 W.	440432
	<i>Thermal Glass, 230 V, 100 W.</i>	<i>440433</i>
13	Window Clamp & Gasket Assy, Vertical.	660617
14	Window Clamp & Gasket Assy, Horizontal	660617-1
15	Window Frame Support.	600757
NOTE: Items highlighted in <i>Bold Italics</i> are used in export models only.		

960 / Delivery Bin Assembly

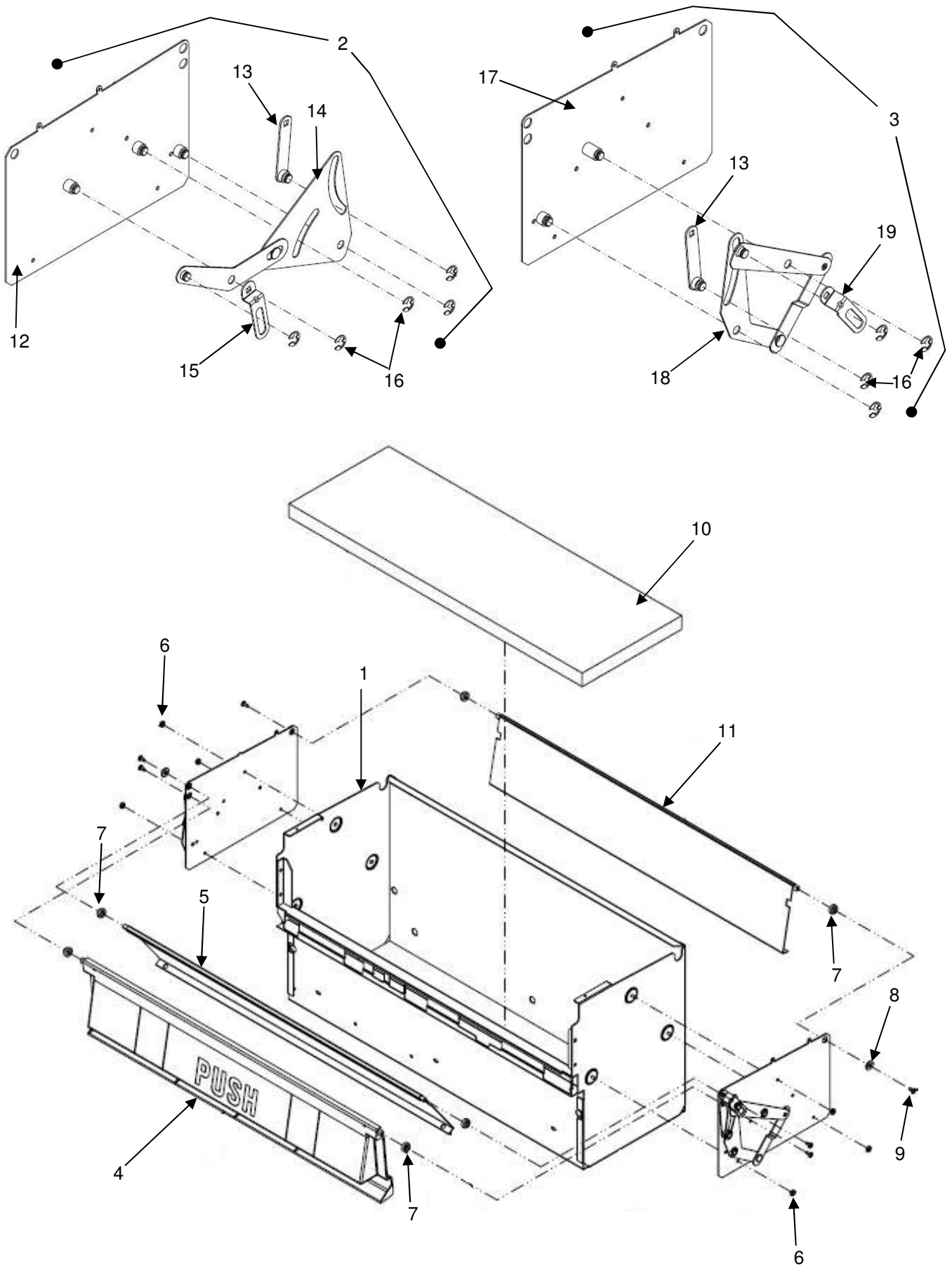

960 / Delivery Bin Assembly

Key	Description	Part No.
1	Delivery Bin, Complete	16600490
	Weldment, Delivery Bin 320	16000396
2	Bin End Linkage Assy, Hinge Side	16600491
3	Bin End Linkage Assy, Lock Side	16600491-01
4	Door, Delivery Bin	440373
5	Door, Inner Bin	202765
6	Nut, 8-32 Keps ZN	438-8
7	Bearing, Door	440129
8	Washer, Bin Door	420282
9	Screw, 8-32 x 3/8 PH T-23 ZN & Wax	276-8R6
10	Pad, Delivery Bin	420348
11	Door, Rear Bin	12000716
12	Plate Assy, Bin End, Hinge Side	16400089
13	Drive Arm, Front Door, Hinge & Lock Side	640209
14	Drive Assy, Rear Bin Door, Hinge Side	640208
15	Drive Arm, Rear Bin Door, Hinge Side	202497
16	Retaining Ring, 3/8	751-37
17	Plate Assy, Bin End, Lock Side	16400089-01
18	Drive Assy, Rear Bin Door, Lock Side	640210
19	Drive Arm, Front Inner Door, Lock side	202501

960 / Golden Eye Assembly

Hinge Side

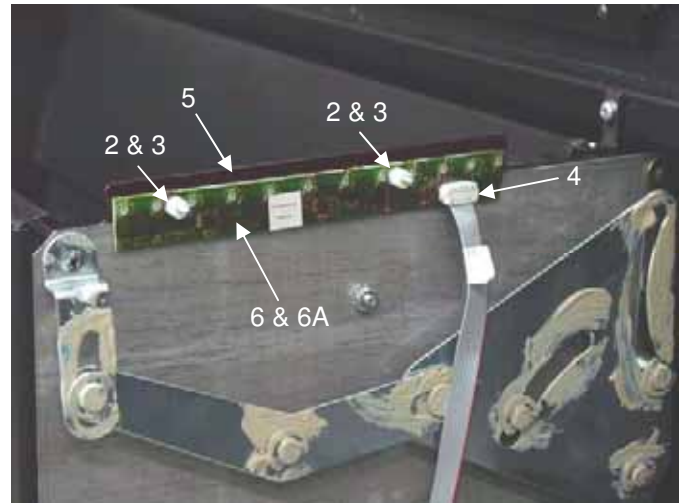
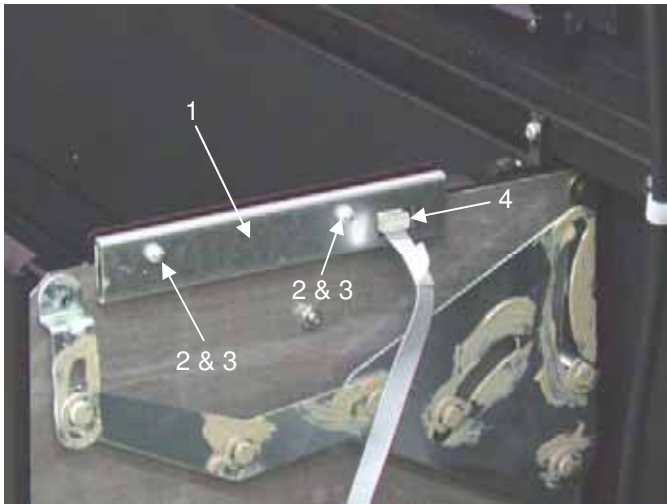

Lock Side

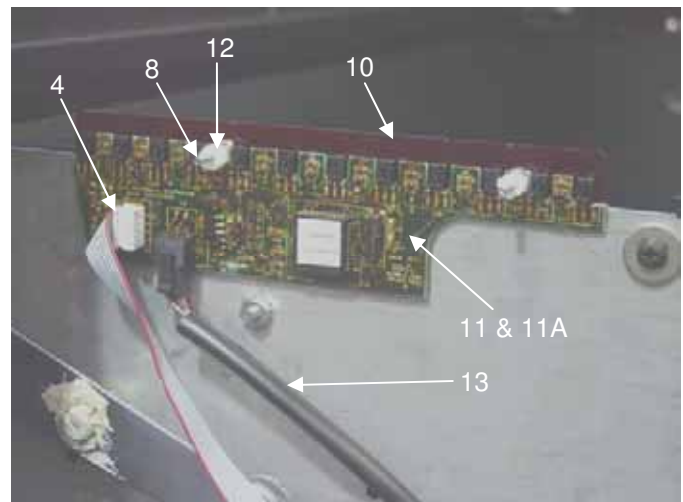
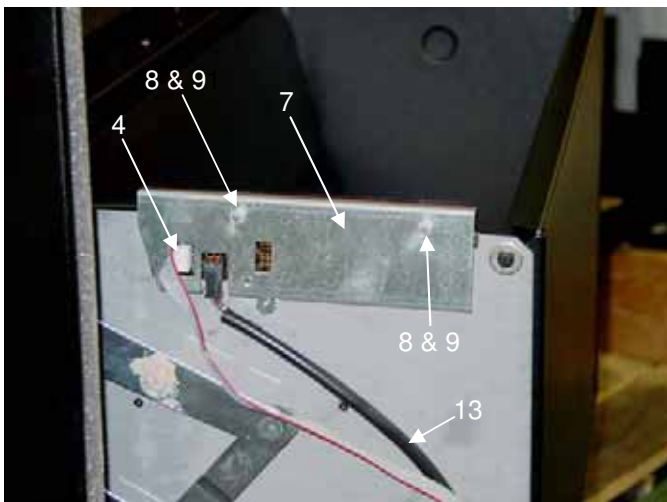

960 / Golden Eye Assembly

Key	Description	Part No.
1	Cover, GE Transmitter, Hinge Side	12000876
2	Screw, 4-40 x 1/2 Pan Hd	116-4R8
3	Nut, #4-40 Hex Nylon	13100028
4	Harness, GE Interconnect	16800101-03
5	Lens, GE Hinge Side	14400038-01
6	Board, GE LED Assy, Transmitter	13600022-03
6A	Insulator, GE Transmitter Board	14400097
7	Cover, GE Receiver, Lock Side	12000875
8	Screw, 4-40 x 3/4 Pan Hd	116-4R12
9	Nut, #4-40 Hex Nylon	13100028
10	Lens, GE Lock Side	14400038
11	Board, GE Sensor Assy, Receiver	13600020-03
11A	Insulator, GE Sensor Board	14400096
12	Standoff, Threaded	13100052
13	Part of Communication Cable See Page 6.20	

960 / Inside Cabinet

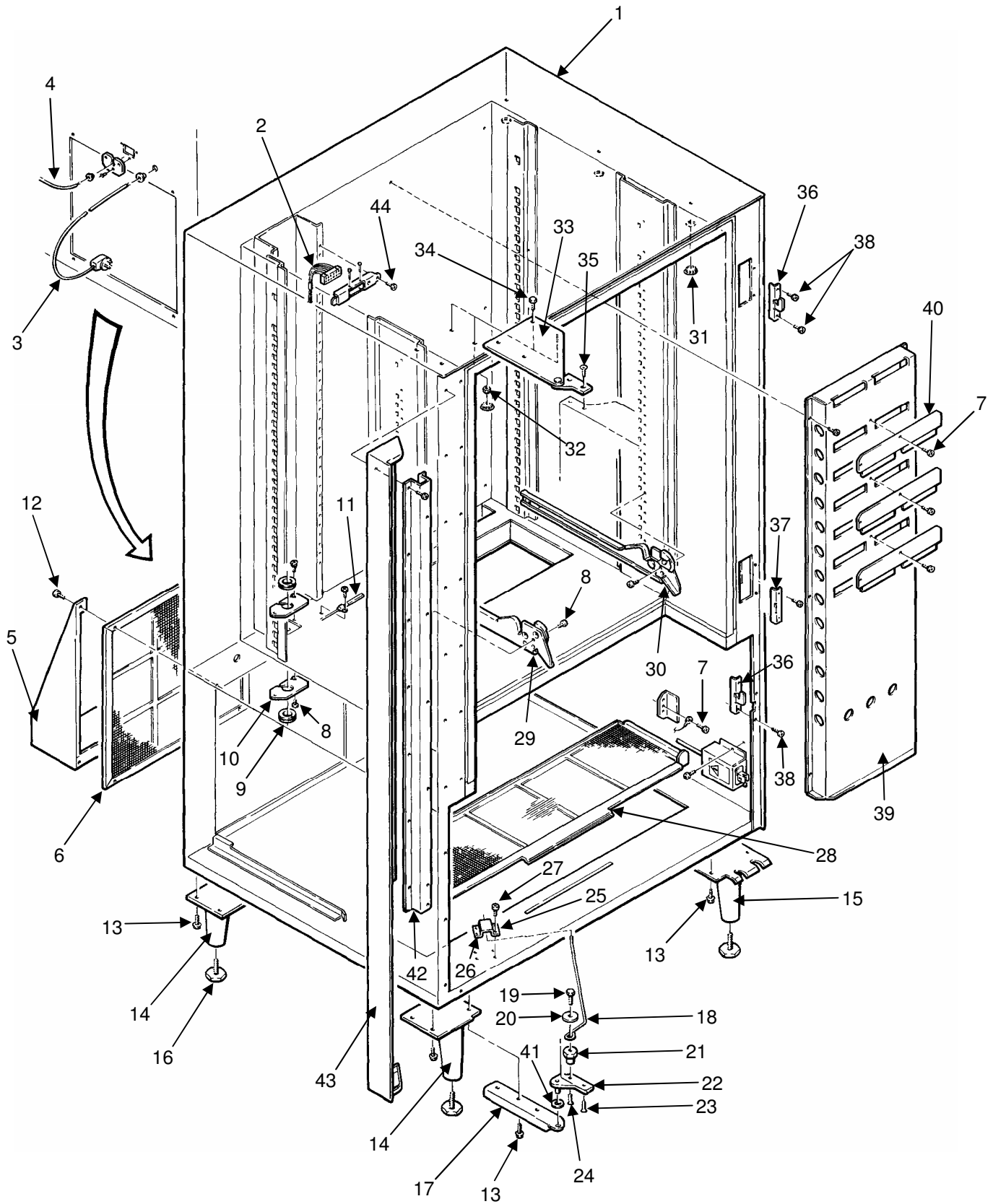

960 / Inside Cabinet

Key	Description	Part No.
1	Foamed Cabinet Assembly	660620
2	Cabinet Back Harness Assy	660654
	Bracket Only	202748
3	Line Cord, 120V, Domestic	16800154
	<i>Line Cord, 230V, Europe</i>	<i>680501</i>
	<i>Line Cord, 230V, Australia</i>	<i>380275</i>
	<i>Line Cord, 230V, Israel</i>	<i>680544</i>
	<i>Line Cord, 230V, UK</i>	<i>680571</i>
4	Communications Cable	16600324
5	Air Deflector	202593
6	Back Vent Screen Assembly.	660613
7	Screw, #8 X 1/2 Nibs Head.	210-8R8
8	Screw, 8-32 x 3/8 Nibs Head.	276-8R6
9	Grommet, 3/4 ID X 1 3/8 OD	420135-6
10	Plate, Shelf Harness	202519
11	Harness, Temperature Sensing	680656
12	Screw 8-32 x 1/2 Pan Head	276-8R8
13	Screw, 5/16-18 X 3/4, Hex Head	420187
14	Leg, Specify Color	600195
15	Leg, Front, Lock Side, Specify Color	600197
16	Leg Leveler	300103
17	Lower Hinge Plate	202606
18	Door Stop Rod	400193
19	Bolt, 1/4-20 X 3/8 Hex Head	114-41-6
20	Washer	420010-10
21	Door Stop Anchor	300156
22	Lower Door Hinge Plate Assy	640157
23	Screw, 1/4-20X1/2 FI Torx	13100035
24	Screw, 1/4-20X1 FI Torx	13100035-01
25	Door Stop Friction Pad	440204
26	Door Stop Plate	201042
27	Screw, #10-32 X 1" Pan Head	277-10R16
28	Vent Screen, Perforated Base	12000399
	Clip, Vent Screen	460704
29	Shelf Track Assembly, Left	202090-2
30	Shelf Track Assembly, Right	640177-3
31	Hole Plug, 1"	420349
32	Nut, 1/4 -20 Keps	438-41
33	Top Hinge Assy	640217
34	Srew, 5/16 - 18 X 5/8 Hex Head	114-51-10
35	Screw, 1/4-20X1/2 FI Torx	13100035
36	Door Lock Catch.	12000290
37	Inner Door Lock Catch	201424-1
38	Screw, 1/4 - 20 X 1/2 Round Head	100-41R8
39	Cold Air Duct, Cabinet	202514
40	Cover, Cold Air Duct	202515
41	WASHER, 1.06Od 0.53ID 0.90	420010-24
42	Window Hinge Bracket	202607
43	Cabinet Door Filler	600759
44	Shoulder Screw, Cab Back Harness	13100064
NS	Kick Plate	660146-15
NS	Catch Pan Assy	16600289

NOTE: Items highlighted in *Bold Italics* are used in export models only.

960 / Baffle Door Assembly

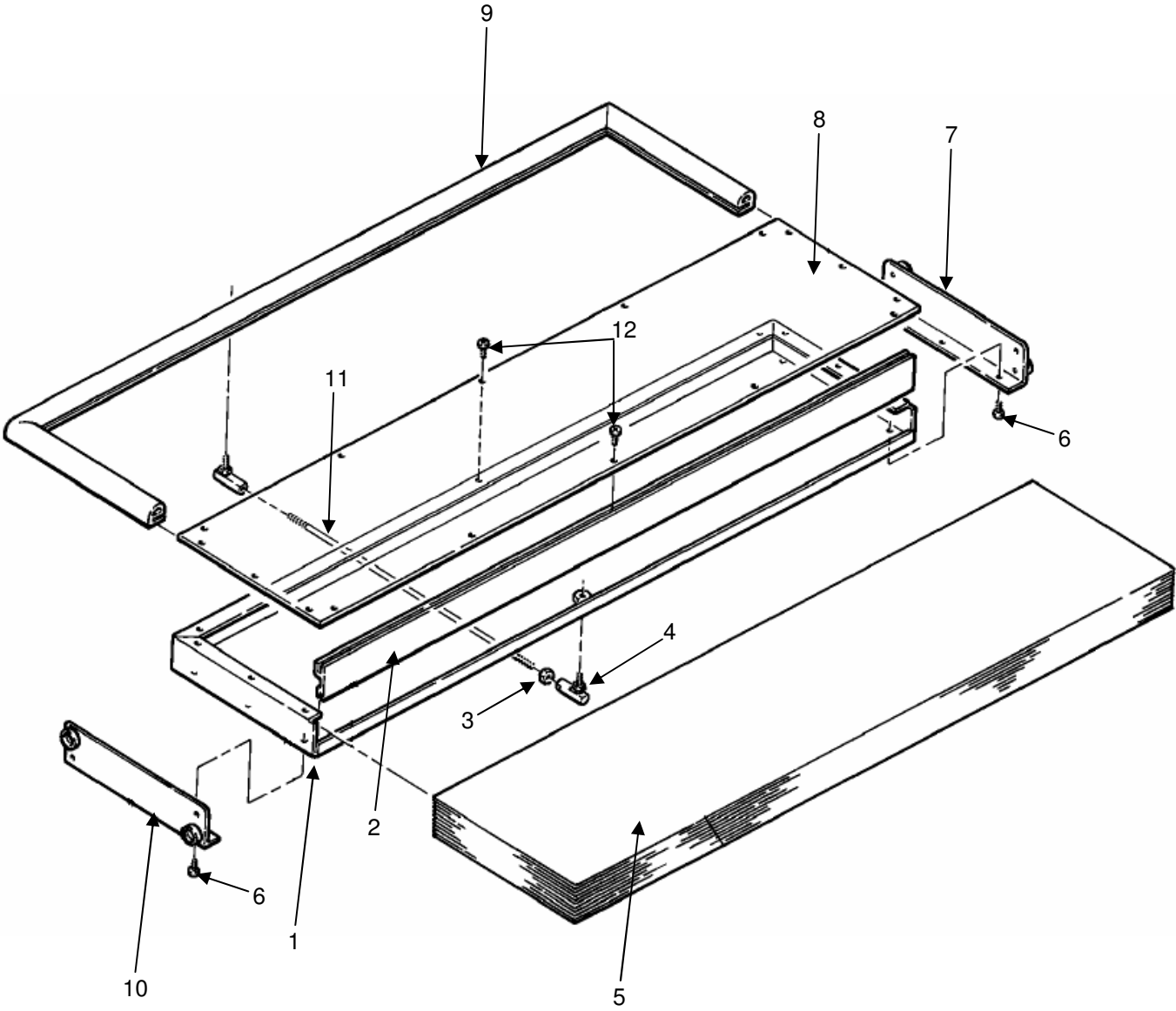

960 / Baffle Door Assembly

Key	Description	Part No.
1	Baffle Door Assembly Complete	660597
	Baffle Door Weldment	600732
2	Baffle Door Front	440427
3	Nut, Order Item 11	
4	Link Arm, Order Item 11	
5	Sliding Door Insulation	420350
6	Screw, #8 X 1/2 PH TR/NIBS BL MA	210-8R8
7	Roller Mounting Bracket Assembly, Lock Side	640214-1
8	Plastic Top, Baffle Door	440426
9	Gasket, Baffle Door	460759
10	Roller Mounting Bracket Assembly, Hinge Side	640214
11	Slide Rod/Ball Joint, Assy, Includes item 3 & 4	420352
12	Screw, #10X3/8 PH THTS TYP	13100070

960 / Baffle Motor Assembly

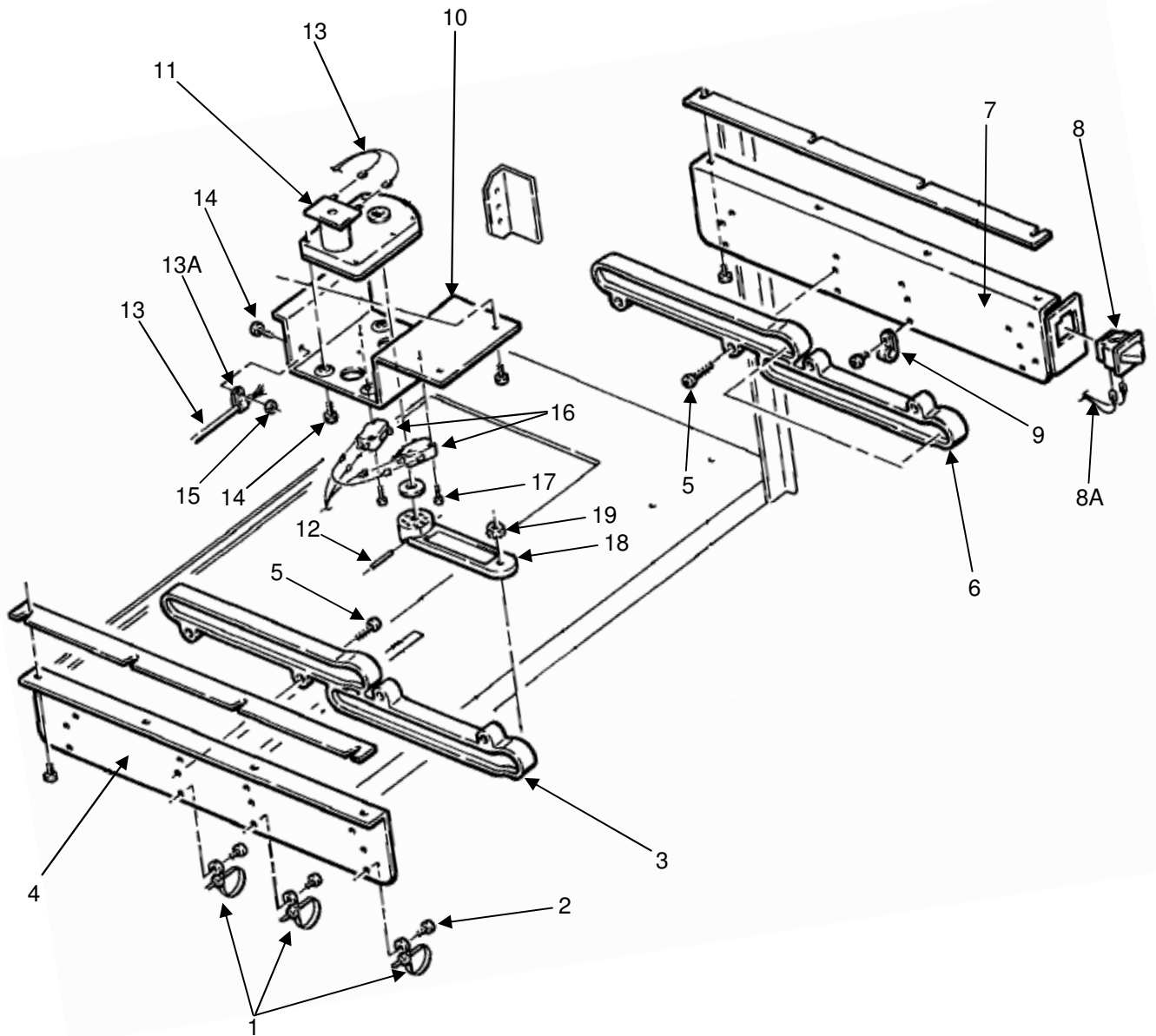

960 / Baffle Motor Assembly

Key	Description	Part No.
1	Cable Tie	380078
2	Screw, 8-32 X 3/8 Pan Head	276-8R6
3	Track Support Assembly Complete, Hinge Side. Includes Items 4 & 5	660596
	Track Only, Hinge Side, Baffle Door	440424
4	Track Mounting Bracket, Hinge Side	202520
5	Screw, 8-23 X 3/4 Pan Head	276-8R12
6	Track Support Assembly Complete, Lock Side. Includes Items 7 & 5	660595
	Track Only, Lock Side, Baffle Door.	440424
7	Track Mounting Bracket, Lock Side	600731
8	Switch, Door Switch Only	360258
8A	Harness, Door Switch	680657
9	Nylon Cable Tie	420035-6
10	Motor Assembly Complete	660655
	Motor Support Bracket	202745
11	Motor, Baffle Door	360223
12	Roll Pin	13100024
13	Harness, Baffle Door Motor to FDB	16800103
13A	Nylon Cable Clamp	420035-1
14	Screw, 8-32 X 1/2 PH RND HD TYP	276-8R8B
15	Nut, 8-32 Hex	404-8
16	Switch, Baffle Door Motor	380306
17	Screw, 4-40 X 9/16 PH RND HD TYP	240-4R9
18	Cam Arm, Baffle Door	440428
19	Nut, 1/4-28 Keps ZN	437-41

960 / Refrigeration Assembly and Components

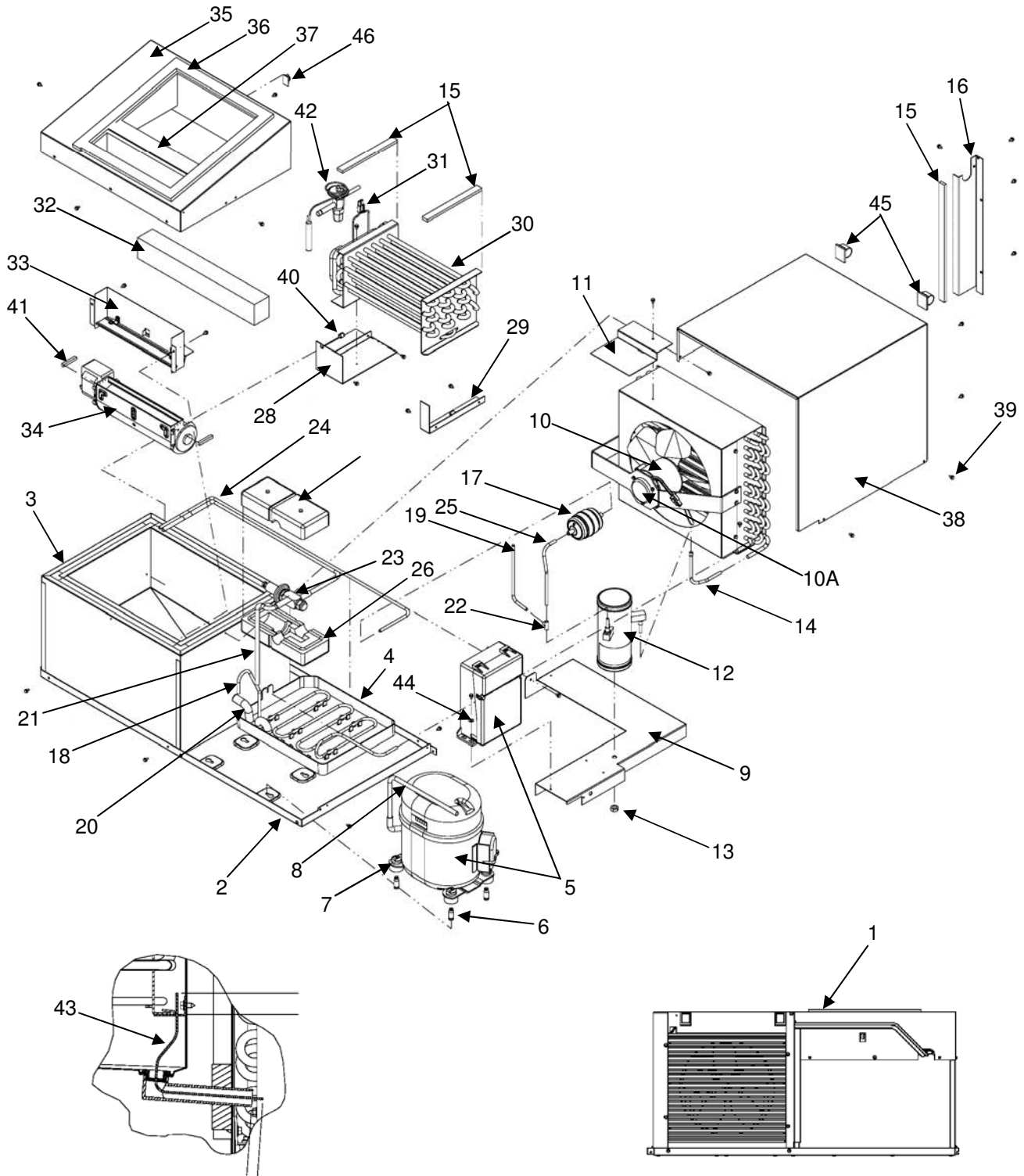

960 / Refrigeration Assembly and Components

Key	Description	Part No.
1	Refrigeration Assembly Complete 120 Volt	16600419
	Refrigeration Assembly Complete 230 Volt	16600419-01
2	Refrigeration Mounting Plate	12000165
3	Foamed Evaporator Housing	16600421
	Kit, Foamed Evaporator Housing	9600003
4	Condensation Pan	14400011
5	Compressor with Start Components 120V	16700031
	Compressor with Start Components 230V	16700011
6	Compressor Mounting Pin	300225
7	Compressor Mounting Clip	420426
8	Tube – Process	12100019
9	Bracket, Refrigeration Mounting	12000864
10	Condenser Fan w/blade, 117V Assy	16700019
	Condenser Fan w/blade, 230V Assy	16700019-01
10A	Condenser Fan Motor Only, 117V	16700020
	Condenser Fan Motor Only, 230V	16700020-01
	Fan Blade Only	16700021
	Bracket Only, Condenser Fan	12000442
	Condenser Shroud	12000441
	Condenser Coil Only	12100012
11	Bracket, CRO Valve	12000170
12	Receiver Tank	12100023
13	Nut, Hex 3/8-16	404-61
14	Tubing Condenser/Receiver 330	12100037
15	Gasket, 13 Inches, Order by Inch	420361
16	Bracket, For Condensing Cover	12000174
17	Drier/Filter, Refrigerant	12100033
18	Tube, Compressor Discharge	12100027
19	Tube, Process	12100005
20	Drain Trap Hose, 330	14400109
21	Return Line	12100016-01
22	Tee Fitting, Receiver/Drier	12100035
23	CRO Valve	12100014
24	Liquid/Suction Line Assy, 330	12100034
25	Tube, Drier/Tee 330	12100036
26	Insulation, Bottom, CRO Valve	12200041
27	Insulation, Top, CRO Valve	12200041-01
28	Bracket, Evaporator, Right	12000754
29	Bracket, Evaporator, Left	12000755
30	Evaporator Coil	12100026
31	Defrost Heater, 117V	360229-2
	Defrost Heater, 230V	360229-3

Key	Description	Part No.
32	Evaporator Air Block	13300029
33	Air Duct Assy	16600420
34	Motor, Evaporator Fan, 117V	16700016
	Motor, Evaporator Fan, 230V	16700016-01
35	Housing, Insulation and Gasket Assy	660610
NS	Insulation Only, Evaporator Housing	460665
NS	Evaporator Housing, Only	202569
36	Gasket, Evaporator Housing Top	420367
NS	Gasket, Evaporator Housing, Underside	420363
37	Gasket, Evaporator Housing Top	420368
NS	Gasket, Evaporator Housing, Underside	420364
38	Cover, Condensing Unit	12000175
39	Screw, Hex 8-32 x 3/8	53100018
40	Bushing, Open/Closed	420318-3
41	Aero Foam Adhesive Backed	460041
42	Valve, Expansion 1/8 Ton	16700013
43	Wire, Defrost Drain	400194
44	Washer, #8	600-8
45	Cable Clamp, Adhesive Backed, 3/4"	420096
46	Cord Clip, Adhesive Backed	420097
NS	Compressor Test Cord	16800098
	Start Components	
NS	Overload, Compressor	16700031-07
NS	Start Capacitor, 117 V	16700031-13
NS	Start Capacitor, 230 V	16700011-03
NS	Start Relay, 117 V	16700031-14
NS	Start Relay, 230 V	16700011-02
NS	Run Capacitor, 230 V	16700011-04
NS	Compressor Harness, 117 V	16800053
NS	Compressor Harness, 230 V	16800053
NOTE: Items highlighted in Bold Italics are used in export models only.		

960 / Junction Box

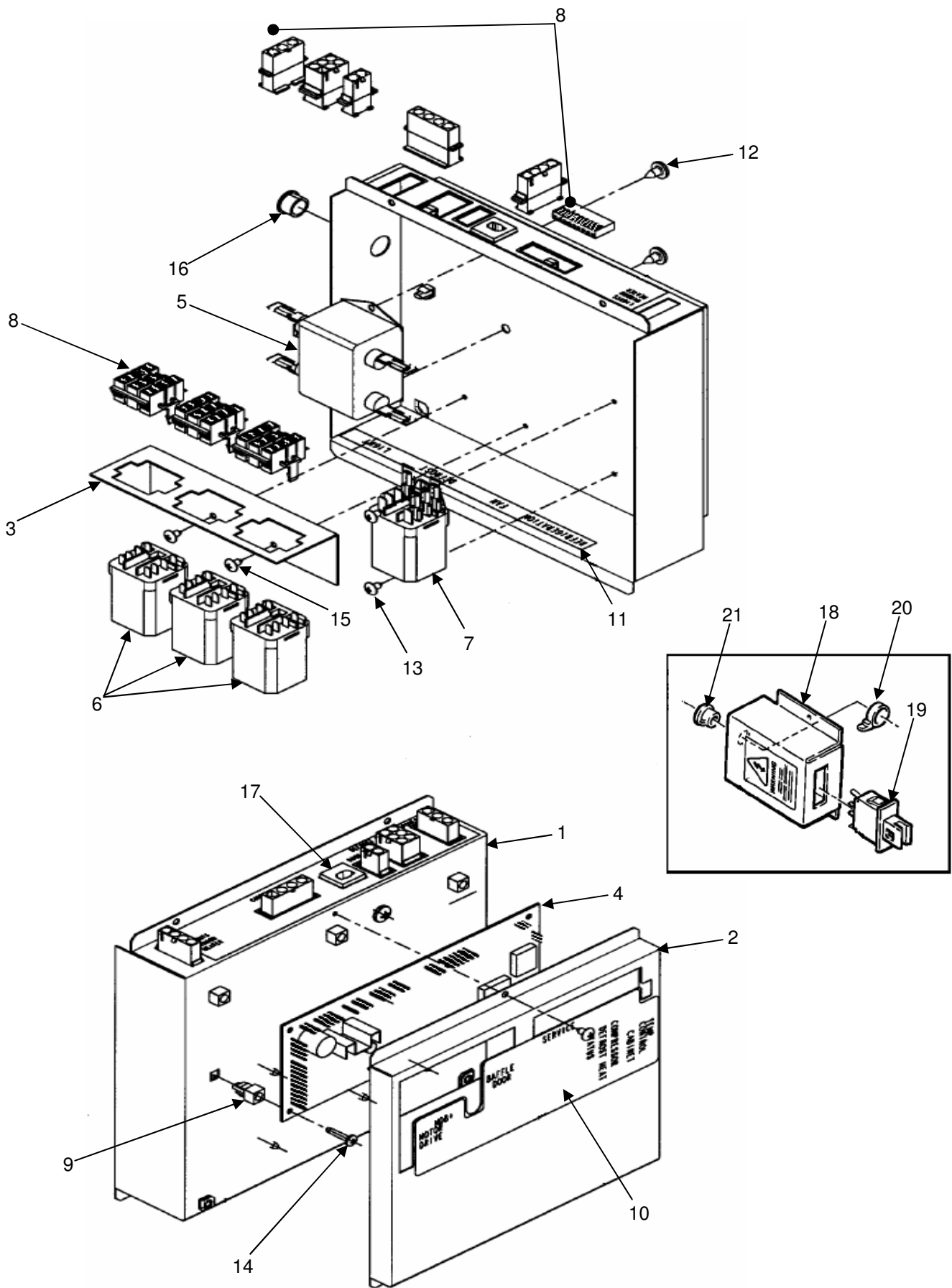

960 / Junction Box

Key	Description	Part No.
1	Junction Box Complete with Food Driver Board	660722
	Junction Box Complete without Food Driver Board	660723
	<i>230 Vac Junction Box Complete with Food Driver Board Export</i>	660724
	<i>230 Vac Junction Box without Food Driver Board Export</i>	660725
	Junction Box Weldment Only	202895
2	Cover, Food Driver Board, No Decal	202896
3	Bracket, Relays	12000541
	<i>Bracket, Relays 230V</i>	12000541-01
4	Food Driver Board	360250
5	RFI Line Filter, 20 Amp	380304
6	Relay, 24VDC, 10 Amp (Fan, Defrost, Light)	16700012
7	Relay, 24VDC, 25 Amp (Compressor)	380322
	<i>Relay, 24VDC, 16 Amp (Compressor)</i>	380313
8	Harness, Junction Box	16800125
	<i>Harness, Junction Box 230V</i>	16800126
9	Board Standoff, 1/4"	17100003
10	Decal, Board Cover	460729
11	Decal, Relay Orientation, Junction Box	460746
12	Screw, 1/4 x 20 NIBS Head	216-41R8
13	Screw, 8 x 3/8 PH	210-8R6
14	Screw, 6 x 1/2 PH HI LO	218-6R8
15	Screw, 8-32 x 3/8 PN NIBS HD T23 BL	276-8R6
16	Plug, Dome 5/8 Hole	420040-1
17	Bushing, Strain Relief, Square	380323
18	<i>Box, Door Switch, Export Only</i>	202843
19	<i>Switch, Door Interlock, Export Only</i>	380262
	<i>Cheat Interlock Tool</i>	380263
20	<i>Cable Tie</i>	380078
21	<i>Snap Bushing, 1/2" Hole</i>	420040-2
NS	Decal, Voltage Disconnect, Not Shown	460642
NS	Decal, Junction Box Plug	460779
	HARNESSES (NOT SHOWN)	
	Line Cord, 120V, Domestic	16800154
	<i>Line Cord, 230V, Europe</i>	680501
	<i>Line Cord, 230V, Australia</i>	380275
	<i>Line Cord, 230V, Israel</i>	680544
	<i>Line Cord, 230V, UK</i>	680571
	Harness, Defrost/Evaporator Fan	680654
	Light Harness, Cabinet to Door	680658
	Harness, Cabinet Back	660654
	Cable, Communications	16600324
	Temperature Sensor	680656
	Harness, Baffle Door	16800103
	Harness, Door Switch	680657
	Harness, Condenser/Compressor	16800053
	NOTE: Items highlighted in <i>Bold Italics</i> are used in export models only.	

960 / 8 Select Spiral Shelf

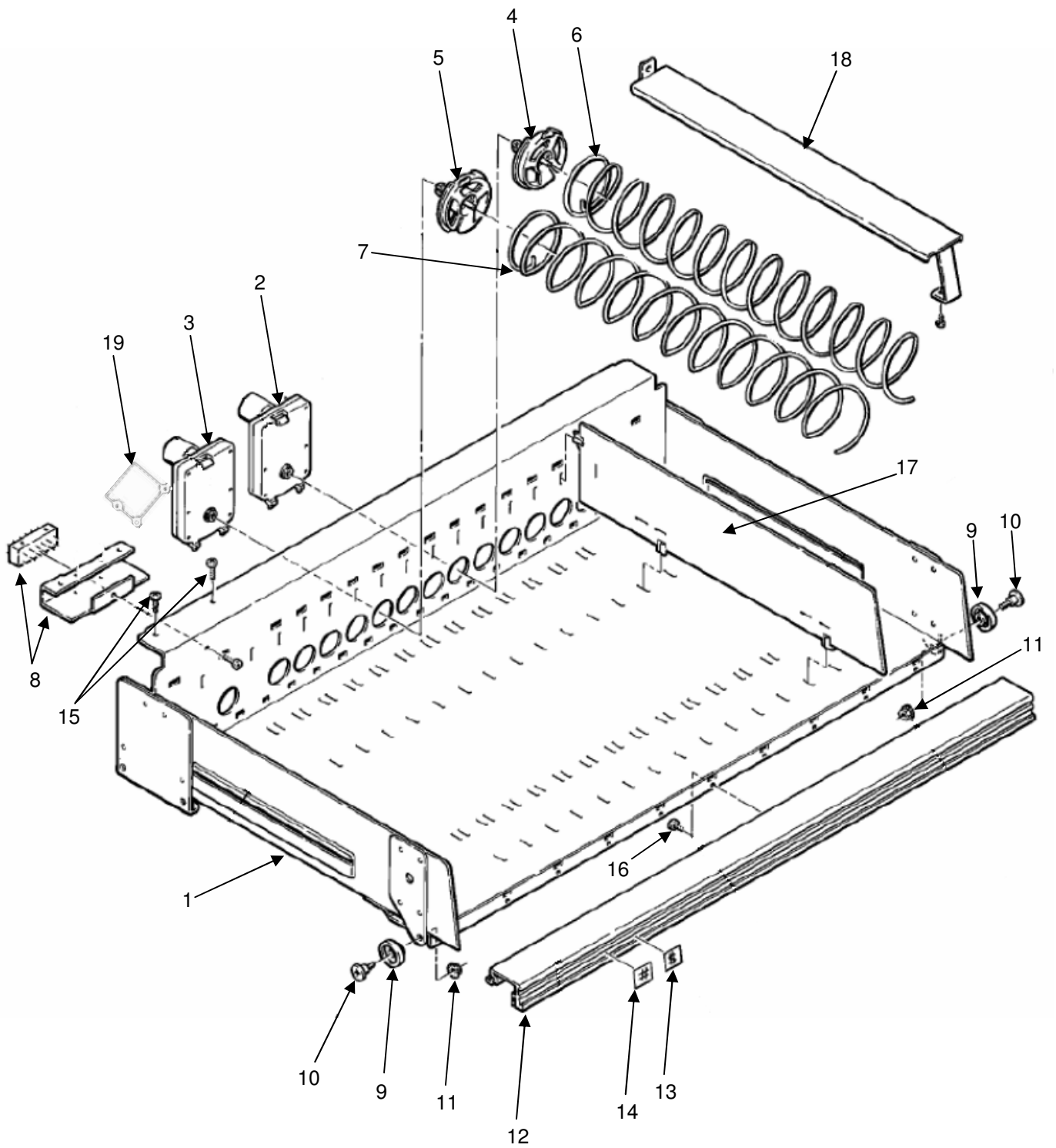

960 / 8 Select Spiral Shelf

Key	Description	Part No.
	Shelf Assembly Complete, Less Motors	
1	8 Select, 8 Motors	660669
	6 Select, 8 Motors	660669-1
	5 Select, 7 Motors	660669-2
	4 Select, 6 Motors	660669-3
	3 Select, 6 Motors	660669-4
	2 Select, 4 Motors	660669-5
	Shelf Weldment	600786
2	CW Motor, Right Hand	360275
3	CCW Motor, Left Hand	360276
4	Spiral Retainer White, Right Hand	440405
5	Spiral Retainer Gray, Left Hand	440406
6	3 Count Spiral, Right Hand, Chrome	400185-1
	4 Count Spiral, Right Hand, Chrome	400183-1
	6 Count Spiral, Right Hand, Chrome	400173-1
	8 Count Spiral, Right Hand, Chrome	400116-1
	10 Count Spiral, Right Hand, Chrome	400117-1
7	3 Count Spiral, Left Hand, Chrome	400186-1
	4 Count Spiral, Left Hand, Chrome	400184-1
	6 Count Spiral, Left Hand, Chrome	400174-1
	8 Count Spiral, Left Hand, Chrome	400175-1
	10 Count Spiral, Left Hand, Chrome	400176-1
8	Shelf Harness Assembly	660653
	Shelf Harness, without bracket	680625
	Bracket Only	600790
9	Shelf Roller	440362
10	Shelf Roller Screw	300203
11	1/4 - 28 Kep Nut	437-41
12	Trim, Shelf Front	340067
13	Price Tabs, assorted	460684
	Price Tabs, Assorted, Italy	14600028
14	Selection Tabs	460683
15	8-18X3/8 Pan Head Screw	216-8R6
16	8-32X3/8 Nibs Head Screw	276-8R5
17	Shelf Divider	202759
18	Product Rail	660686
19	Motor Cover	440460
NS	Riser, 1.04" Wide	202506
NS	Riser, 2.39" Wide	202506-1
NS	Riser, 3.7" Wide	202506-2
NS	Riser, 5.069" Wide	202506-3
NS	Product Pusher, Left Hand	440215
NS	Product Pusher, Right Hand	440141-1
NS	Storage Shelf Add On Kit	750204
NS	Deflector Bottom Tray	12000602
NS	Pins, Shelf Harness (Repair Part Only)	420142

Key	Description	Part No.
	Spiral Kits	
	320R kit Includes	750199
	2 – 1.064" Product Riser	
	1 – 2.399" Product Riser	
	10 – Shelf Dividers	
	2 – 8 Space Left Hand Spirals	
	2 – 8 Space Right Hand Spirals	
	2 – 6 Space Left Hand Spirals	
	2 – 6 Space Right Hand Spirals	
	4 – 4 Space Left Hand Spirals	
	4 – 4 Space Right Hand Spirals	
	2 – 3 Space Left Hand Spirals	
	2 – 3 Space Right Hand Spirals	
	2 – Spiral Retainer Left	
	2 – Spiral Retainer Right	
	2 – Product Rail	
	320F Kit Includes	750200
	1– 1.064" Product Riser	
	1 – 2.399" Product Riser	
	1 – 3.734" Product Riser	
	1 – 5.069" Product Riser	
	10 – Shelf Dividers	
	2 – 8 Space Left Hand Spirals	
	2 – 8 Space Right Hand Spirals	
	2 – 6 Space Left Hand Spirals	
	2 – 6 Space Right Hand Spirals	
	2 – Spiral Retainer Left	
	2 – Spiral Retainer Right	
	2 – Product Rail	
	320FN Kit Includes	750201
	4– 1.064" Product Riser	
	2 – 6 Space Left Hand Spirals	
	2 – 6 Space Right Hand Spirals	

965 / Trim & Panels

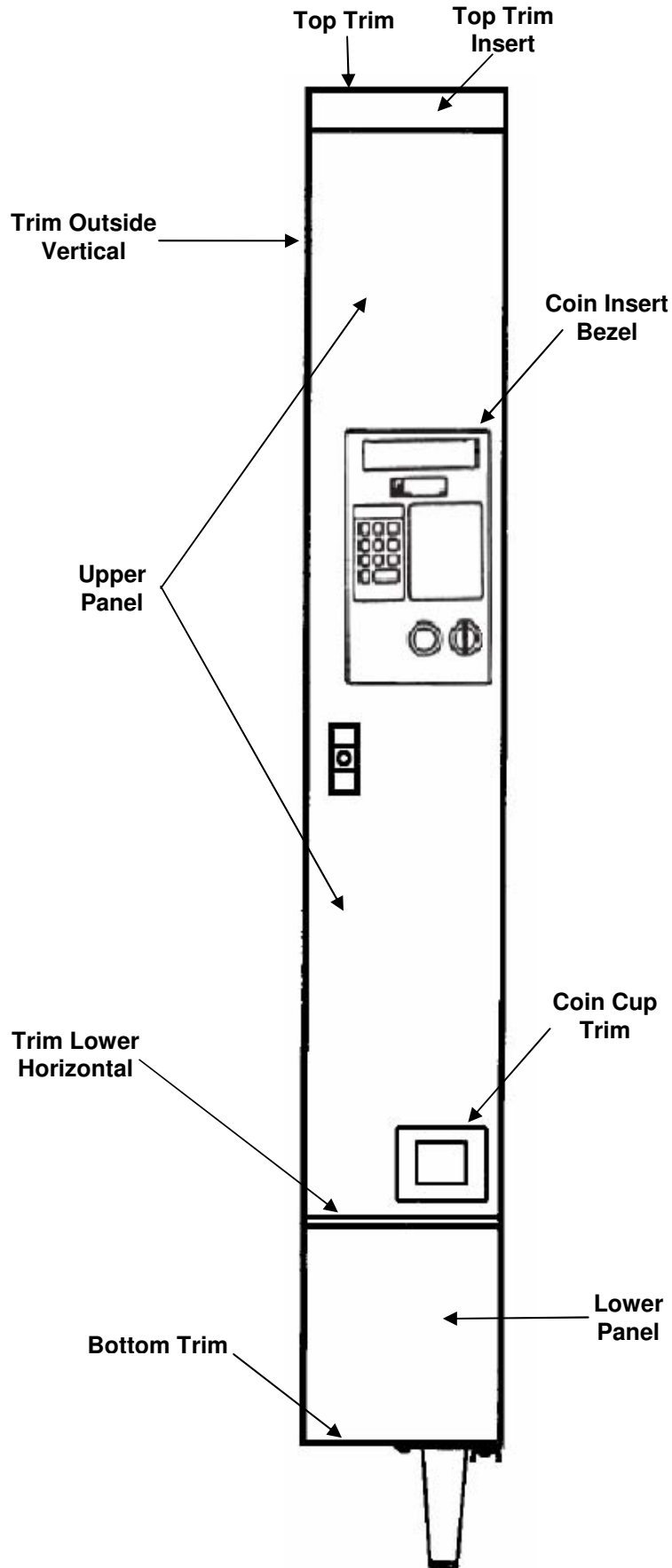

965 / Trim & Panels

965 Trim & Panels			Metro	Aramark	
Top Trim	Profile	Part #			Dimensions
Black - AP Style		13400021-18	1		9.155 Inches
Silver - AP Style		13400021-07		1	8.769 Inches
Top Trim Insert					
Black		14400137-08	1		1.70 x 9.120 in
ARA - Style		14400137-04		1	1.70 x 8.754 in
Outside Vertical Trim					
Black	D	13400030	2		65.609 Inches
Silver -Taped Trim	A	16600402		2	65.609 Inches
Lower Horizontal Trim					
Black	C	13400013-20	1		9.155 Inches
Silver	B	13400024-05		1	8.769 Inches
Upper Panel - Cover					
Black, Paint		9652003	1		9.109 x 53.269 in
Black Pica		9652011		1	9.109 x 53.269 in
Bison Black		9652017		1	9.109 x 53.269 in
Upper Panel - 3rd Pay					
Black, Paint		9652004	1		9.109 x 53.269 in
Black Pica		9652012		1	9.109 x 53.269 in
Bison Black		9652018		1	9.109 x 53.269 in
Upper Panel - POS					
Black, Paint		9652005	1		9.109 x 53.269 in
Black Pica		9652013		1	9.109 x 53.269 in
Bison Black		9652019		1	9.109 x 53.269 in
Lower Panel					
Black Pica		202530-9		1	9.109 x 10.906 in
Black Hide		202530-6		1	9.109 x 10.906 in
Bottom Trim					
Edging		202470-1		1	7.375 Inches
Coin Insert Bezel					
Black, w/o Rib		440444-2	1	1	
Coin Cup Trim					
Black		16600403	1	1	
Trim Screws					
Self Tap x .480 Long		13100054	24	24	

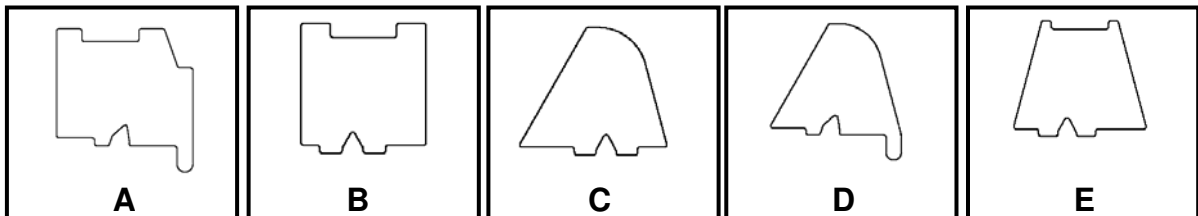

965 Series Trim Profile Chart

960 / Trim & Panels

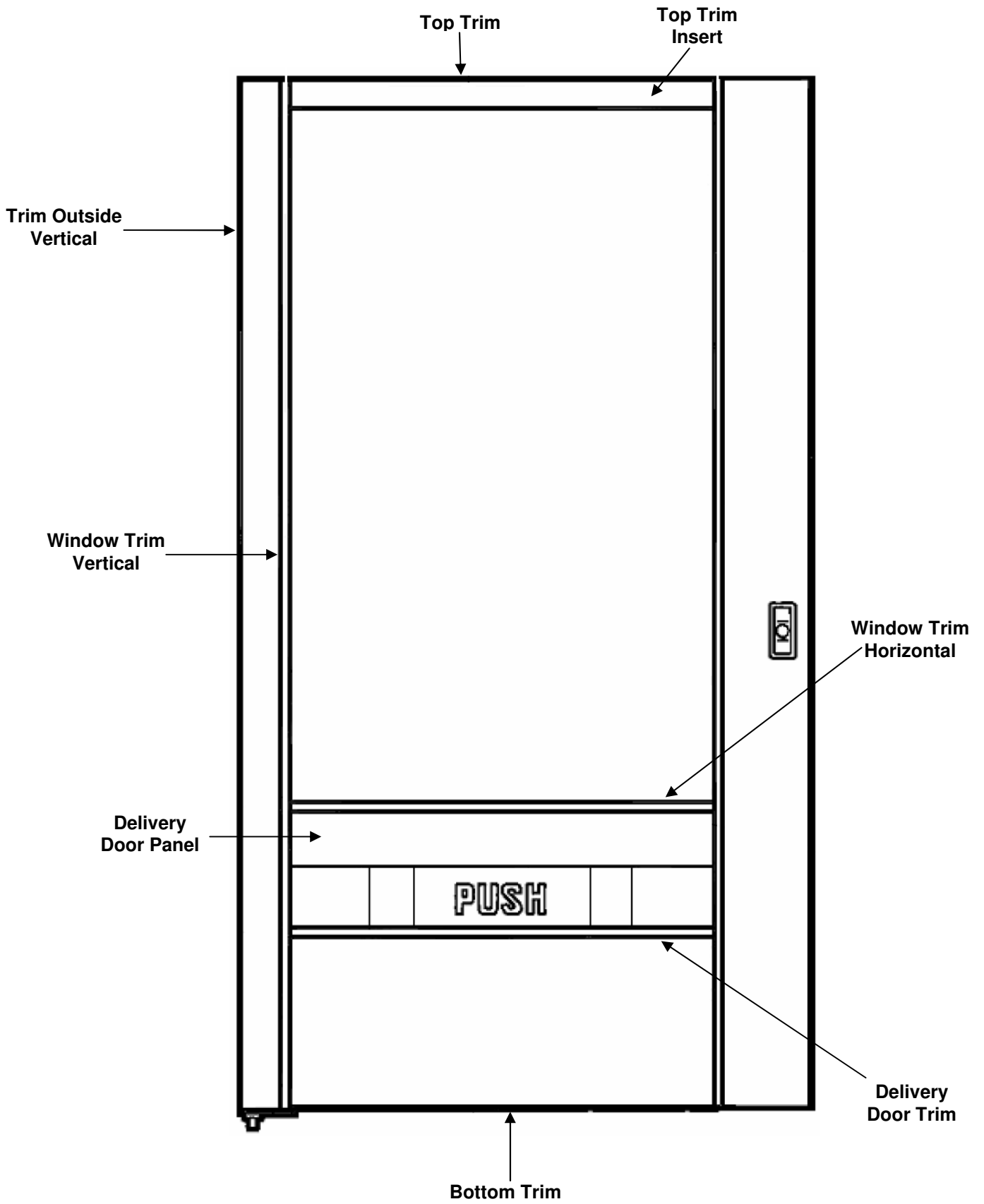

960 / Trim & Panels

960 Trim			Metro	Aramark	
Top Trim	Profile	Part #			Dimensions
Black - AP Style		13400021-12		1	1.872 x 35.937 in
Black - AP Style		13400021-16	1		1.872 x 36.300 in
Top Trim Insert					
Black		14400137-10	1		1.70 x 36.265 in
ARA - Style		14400137		1	1.70 x 36.890 in
Outside Vertical Trim					
Black	D	13400030	2		65.609 inches
Silver - Taped Trim	A	16600402		2	65.609 inches
Window Vertical Trim					
Silver	E	13400012-02		2	52.394 inches
Black - Right Hand	C	13400013-17	1		52.595 inches
Black - Left Hand	C	13400013-18	1		52.595 inches
Window Horizontal Trim					
Silver	E	13400012		1	26.721 inches
Black	C	13400013-19	1		27.030 inches
Delivery Door Trim					
Silver	B	13400024-04		1	35.937 inches
Black	C	13400013-16	1		36.300 inches
Delivery Door Panel					
Black Hide		202535-1	1		3.694 x 26.843 in
Bottom Trim					
Edging		202469		1	34.109 inches
Trim Screws					
Self Tap x .480 Long		13100054	57	39	

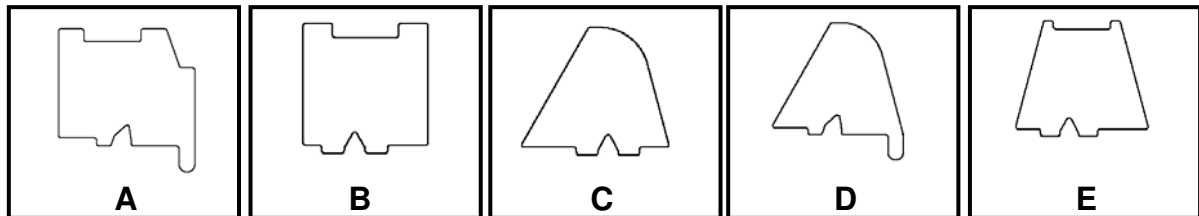

960 Series Trim Profile Chart

Troubleshooting

LCB BOARD CONNECTIONS

P1 KEYPAD SWITCH LINES

1	Row 1
2	Row 2
3	Row 3
4	Row 4
5	Row 5
6	Key
7	Col 1
8	Col 2
9	Col 3
10	N/C

Switch #	Connection A	Connection B
1	PIN 1	PIN 7
2	PIN 1	PIN 8
3	PIN 1	PIN 9
4	PIN 2	PIN 7
5	PIN 2	PIN 8
6	PIN 2	PIN 9
7	PIN 3	PIN 7
8	PIN 3	PIN 8
9	PIN 3	PIN 9
*	PIN 4	PIN 7
0	PIN 4	PIN 8
#	PIN 4	PIN 9
<-	PIN 5	PIN 7
C	PIN 5	PIN 8
->	PIN 5	PIN 9

P2 SERVICE

1	24VDC
2	UNDEDICATED RELAY OUTPUT
3	SHUTDOWN SWITCH
4	SHUTDOWN SWITCH SCAN
5	KEY
6	DOOR SWITCH
7	DOOR SWITCH SCAN

P3 POWER

1	24 VAC
2	VAC COMMON
3	8 VAC
4	N/C
5	KEY
6	EARTH GROUND

P4 MDB +

1	34VDC
2	PWR GND
3	8 VDC
4	MASTER RXD
5	MASTER TXD
6	COMMUNICATION COMMON

P5 SERIAL INTERFACE

1	MASTER RECEIVE DATA
2	GND
3	MASTER TRANSMIT DATA
4	KEY
5	N/C
6	+5 VOLTS

P6 NOT USED ON 965/960

P7 CHIP

1	INPUT/OUTPUT LINE
2	N/C
3	KEY
4	GND

P8 FLIP

1	VCC
2	ALE
3	TXD
4	RXD
5	PSEN
6	GROUND

P9 BATTERY

1	+
2	-

P10 LIGHT RELAY

1	24VDC
2	LIGHT RELAY CONTROL

P11 GOLDEN EYE/COFFEE SELECTION

1	GE ENABLE 1/DATA OUT
2	GE SIGNAL 1/DATA IN
3	GE ENABLE 2/CLOCK
4	STROBE
5	GE GROUND/GROUND
6	Key
7	GE POWER/8VDC
8	GE SIGNAL 2
9	GROUND

P12 DISPLAY

1	GROUND
2	5VDC
3	N/C
4	RS
5	WR NOT
6	KEY
7	DB0

P12 DISPLAY

8	DB1
9	DB2
10	DB3
11	DB4
12	DB5
13	DB6
14	DB7

Troubleshooting

Error on display	Definition of Error	Possible Solutions
MOTOR ERRORS		
MOTOR XXX DIDNT HOME	Vend motor Time Out - XXX represents the selection motor	Motor left the home position, and never returned in the allotted time <ul style="list-style-type: none"> • Check for jammed product in spiral • Check for loose wire on motor
MOTOR XXX STALLED	Vend motor Over Current	While the motor was running, the current used by the motor exceeded a pre-set threshold <ul style="list-style-type: none"> • Check for jammed product in spiral
MOTOR XXX OFF HOME	Vend motor Not Home	After the motor has been scanned by the board, and checked for an "at Home" condition, the motor is still not at home <ul style="list-style-type: none"> • Check for a product jam
BAFFLE x CURRENT	Baffle Motor Over Current – X indicates which cabinet	The baffle door in the A LA CARTE has experienced an over current condition while attempting to open or close. <ul style="list-style-type: none"> • Check baffle door rod for correct adjustment • Open door and inspect left and right track for dirt – clean as required • Check harness to motor for loose connections • Check for obstructions from delivery bin
BAFFLE x TIMEOUT	Baffle Motor Timeout - X indicates which cabinet	Motor left the home position, and never reached the open position in the allotted time, or visa versa <ul style="list-style-type: none"> • Check harness to open and closed position switch • Check switches for proper operation • Check pin on baffle door motor crank arm
LOW VOLTAGE	Low voltage was detected during a Vend	This error will only appear during a vend. This error indicates that a pre-set low voltage threshold was reached for the motor supply circuit. <ul style="list-style-type: none"> • Check the incoming 120Vac supply to the machine – must be within 10% - no lower than 108V • Check for other machines plugged to the same circuit as this machine – rearrange plugs if possible

Troubleshooting

CONTROL BOARD & SOFTWARE ERRORS	
KEYPAD SW X STUCK	Keypad Switch X Stuck down Either a key on the keypad is stuck or there is damage to the harness from the keypad to the logic board <ul style="list-style-type: none"> • Check the keypad for a broken or damaged button • Check the harness for a pinched or shorted wire
CABx COMM ERROR	Cabinet Communication error The Logic Control Board (LCB) has lost communication to the FDB. <ul style="list-style-type: none"> • Check the communications harness between the two boards for damage. If any damage is found, harness should be replaced • Check position of Cabinet Jumper on FDB (C1 or C2) for correct position • Power down and disconnect any MDB payment peripherals, restore power and see if error repeats.
RAM CHKSUM	RAM CHKSUM This error will only appear during a power up cycle, and is the result of the contents of the flash memory not agreeing with the stored memory contents on the board. <ul style="list-style-type: none"> • Inspect the board for any physical damage to the smaller flash chip • Access the service mode and perform a complete reset of the control board.
ROM CHKSUM	ROM CHKSUM This message will only appear during a power up cycle. The memory contents of the microprocessor on the board have been corrupted, and are not recoverable. The control board must be replaced.
SW TRAP ERROR - XX	Software Trap TBD
TIME / DATE / BATT ERROR	Time and date have not been set. Battery has failed.

Code	Key	Code	Fast Track Key	Code	Fast Track Key
000	1	040	F1	060	F3
001	4	041	Service Log	061	Event Log
002	7	042	Set Shutdown	062	Set Price
003	*	043	Motor Pairing	063	Bill Escrow
004	<	044	Interval Sales by Selection	064	Historical Sales by Selection
010	2	050	F2	070	Set Message
011	5	051	Temp Log	071	Golden Eye
012	8	052	Set Temp	072	Set Time
013	0	053	Test Vend	073	Tube Fill
014	C	054	Interval Sales Summary	074	Historical Sales Summary

Key Pad Switch Stuck Error Codes

Troubleshooting

TEMPERATURE SENSE ERRORS		
HEALTH SHUTDOWN CAB x	Health Shut down - X indicates which cabinet	This error indicates that the temperature inside the controlled cabinet has exceeded the maximum set temperature for a pre-set period of time. Check the Health Code Error for date and time of occurrence, along with duration and highest temperature reached.
TEMP CAB1 L ZN OPEN TEMP CAB1 H ZN OPEN TEMP CAB2 OPEN	Temperature Sensor CAB X YY ZONE Open X indicates which cabinet YY indicates upper (H ZN) or lower (L ZN)	The Refrigeration Driver Board (RDB) or Food Driver Board (FDB) has detected that the temperature sensor for one of the zones or cabinets is reporting a temperature reading which indicates the sensor is open <ul style="list-style-type: none"> • Check connections to the RDB – sensor should be plugged to board on JP3 for the lower section, and JP5 for the upper section, or P2 on the FDB
TEMP CAB1 L ZN RANG TEMP CAB1 H ZN RANG TEMP CAB2 RANG	Temperature Sensor CAB X YY ZONE Out of Range X indicates which cabinet YY indicates upper (HZN) or lower (L ZN)	The RDB or the FDB has detected that the temperature sensor for one of the zones or cabinets is reporting a temperature reading beyond a normal range <ul style="list-style-type: none"> • Check connections to the RDB – sensor should be plugged to board on JP3 for the lower section, and JP5 for the upper section, or P2 on the FDB • Check the temperature probe harness for damage or a short
TEMP X SENSOR BAD	Temperature Sensor error detected – X indicates which cabinet	This error reports a discrepancy in an A LA CARTE between the readings of the defrost bimetal and the temperature sensor. If the bimetal is closed, indicating the refrigeration unit is below 40°F, but the temperature sensor is reporting a temperature that is higher, and error is reported. Also would report an error if the opposite is true – the unit temperature is below 40°F, but the bimetal is open. This error can only occur after a health code period has elapsed. <ul style="list-style-type: none"> • Check P2 connector on FDB • Check for physical damage to the sensor, or the harness • Check the bimetal harness for damage
CABx DEFROST ERROR	Defrost Timeout - X indicates which cabinet	A defrost error is reported when a defrost cycle in an A LA CARTE exceeds 30 minutes. The controller has terminated the defrost cycle, recorded the error, and turned the refrigeration unit back on. <ul style="list-style-type: none"> • Check defrost heater circuit for voltage and resistance or current draw. • Check defrost relay for proper operation • Check the defrost bimetal for proper operation – should open when temperature inside unit reached 50 °F
CABx SWITCH ERROR	Defrost Switch Error-X indicates which cabinet	A Switch error will only occur in a frozen A LA CARTE. This error occurs when upon entering a defrost cycle, the bimetal is checked and shows an open status while the temperature being reported is < 20°F. The error is posted, and a fixed 10 minute defrost cycle occurs. <ul style="list-style-type: none"> • Check defrost harness for damaged wire • Verify operation of bimetal defrost sensor

Troubleshooting

GOLDEN EYE ERRORS		
GOLDENEYE XXX FAILED	3 items missed by the Golden EYE Sensor. XXX indicates which selection.	Error would occur is a selection is empty, or if the spiral became disconnected from the motor. This error is reset if the machine door is opened and closed. The error will not be erased until errors are cleared
CABx GOLDENEYE ERROR	Three different selections in a cabinet missed by the Golden EYE Sensor. X indicates which cabinet	As a result of 3 different selections reporting a Golden Eye error, Golden Eye has been disabled for the entire machine. This error is reset if the machine door is opened and closed. The error will not be erased until errors are cleared. Errors for each individual selection with a Golden Eye error should be also reported.
CABx TRAN + REC BAD	All Transmitters and Receivers bad - X indicates which cabinet.	All receivers cannot see any of the transmitters <ul style="list-style-type: none"> • Confirm ribbon cable between the two boards on the bin is correctly plugged in. • Check ribbon cable for damaged wires.
CABx RECEIVER Y BAD	Receiver (Sensor) Y failed, Y indicates the number of the Sensor, X indicates which cabinet	Sensors are numbered on the G/Eye II boards. Sensor 1 is closest to the glass through # 12 which is closest to the inside of the machine. <ul style="list-style-type: none"> • Check for an obstruction to the specific sensor • Check for physical damage or moisture to the specific sensor
CABx TRANSMTR Y BAD	Transmitter (LED) Y failed, Y indicates the number of the LED, X indicates which cabinet	The transmitter LEDs are numbered on the G/Eye II boards. LED # 1 is closest to the glass through LED # 12 which is closest to the inside of the machine. <ul style="list-style-type: none"> • Check for an obstruction to the specific LED • Check for physical damage or moisture to the specific LED
CABx TRN Y TO REC Y	Transmitters Y not seen by a Receiver Y.	In a machine with Golden Eye II, each transmitter sends a beam across the delivery bin to each of the 12 receivers <ul style="list-style-type: none"> • Check for an obstruction to the specific sensor or LED • Check for physical damage or moisture to the specific sensor or LED

Troubleshooting

COIN MECHANISM ERRORS		
DEFECTIVE TUBE SENSOR	The changer has detected one of the tube sensors behaving abnormally	Review documentation provided by coin mechanism manufacturer for specific instructions to resolve these errors
CM TUBE JAM	A tube payout attempt has resulted in jammed condition	
CM ROM CHECKSUM ERROR	The changers internal checksum does not match the calculated checksum.	
COIN JAM	A coin(s) has jammed in the acceptance path	
COIN ROUTING ERROR	A coin has been validated, but did not follow the intended routing.	
CREDITED COIN REMOVAL	There has been an attempt to remove a credited coin.	
BILL VALIDATOR ERRORS		
BV DEFECTIVE MOTOR	One of the BV motors has failed to perform its expected assignment.	Review documentation provided by bill validator manufacturer for specific instructions to resolve these errors
BV SENSOR PROBLEM	One of the BV sensors has failed to provide its response.	
BV ROM CHECKSUM ERROR	The validators internal checksum does not match the calculated checksum	
BILL REMOVED	A Credited bill in the escrow position has been removed by an unknown means.	
CASH BOX OUT OF POSITION	The validator has detected the cash box to be open or removed.	
CASHLESS PAYMENT SYSTEM ERRORS		
CL PAYMENT MEDIA ERROR	Cashless Payment media Error	Review documentation provided by cashless system manufacturer for specific instructions to resolve these errors
CL INVALID MEDIA	Cashless Invalid Payment media	
CL TAMPER ERROR	Cashless Tamper Error	
CL REFUND ERROR	Cashless internal reader credit lost	
CL COMMUNICATIONS ERROR	Cashless Communications Error	
CL REQUIRES SERVICE	Cashless Reader Requires Service	
CL FAILURE	Cashless Reader Failure	
CL MEDIA JAMMED	Cashless Payment media Jammed	

965 – Software Update Instructions

965 Control Module - Software Update Instructions Using a new Flash Memory Chip



CAUTION: The system components in this machine utilize static sensitive components. Precautions for handling sensitive devices should be observed when handling these items.

1. Note any required meter readings or options set.
2. Turn the power switch off.
3. Use a grounding strap and proper anti -static procedures to avoid Electro Static Discharge (ESD) that could damage components on the board.
4. Remove all harnesses from the board except the ribbon cable to the Selection Switches (P1), Display (P12) and Chip (P7).
5. Remove the one screw from the board cover located on the top horizontal edge of the board cover.
6. Remove the board cover by lifting the board cover upward over the latches and pulling forward.
7. Identify the Flash Memory Socket, remove the old software and install the revised software.

NOTE: Pay special attention to the alignment notch when installing the chip to prevent damage to either the chip or the socket! Three of the corners have square edges and one edge is cut at an angle, the angled corner lines up with the alignment notch as shown. Press the Flash Memory chip firmly into the socket.

8. Re-install the board cover and all harnesses.
9. Turn the power switch back on.
10. Press the mode button on the board. Enter the reset code 89171819 on the selection keypad, this will reset all options and prices back to factory defaults and reset all accountability back to zero.
11. Press and hold the switch on the top of the door until the “No row * message” appears.
12. Set prices, options, and test.

The removed chip should be returned for credit

965 Board
Shown as
installed in
machine.

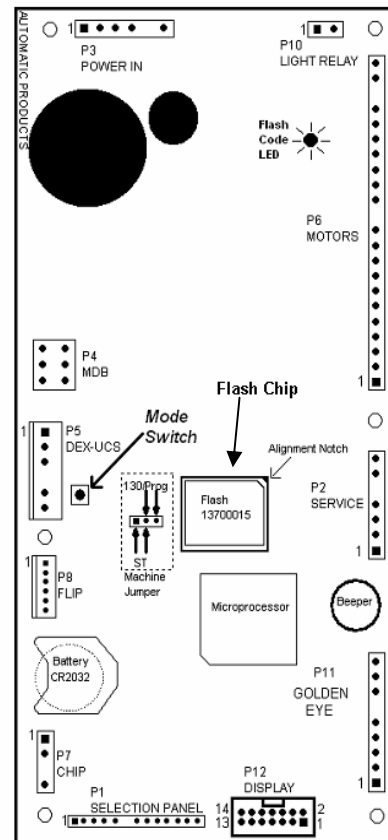

965 Series

120V/230V

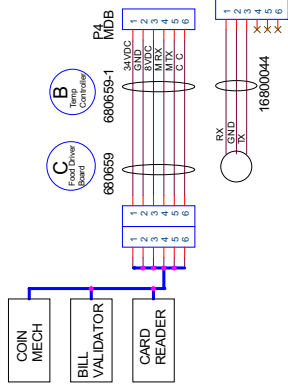
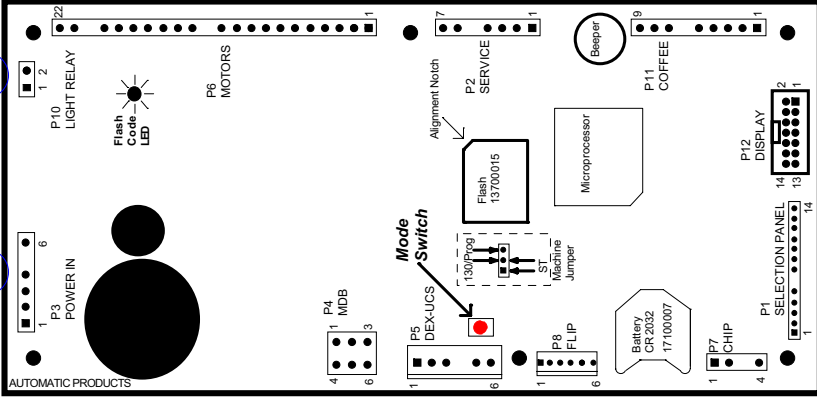

130 SELECTION SWITCH
13800002 (130)

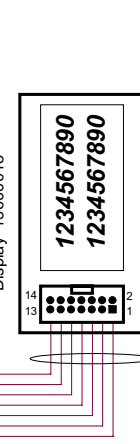
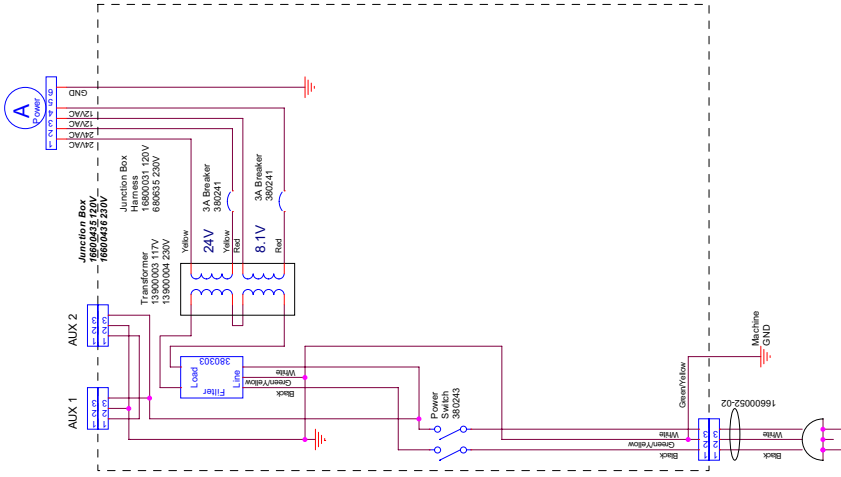
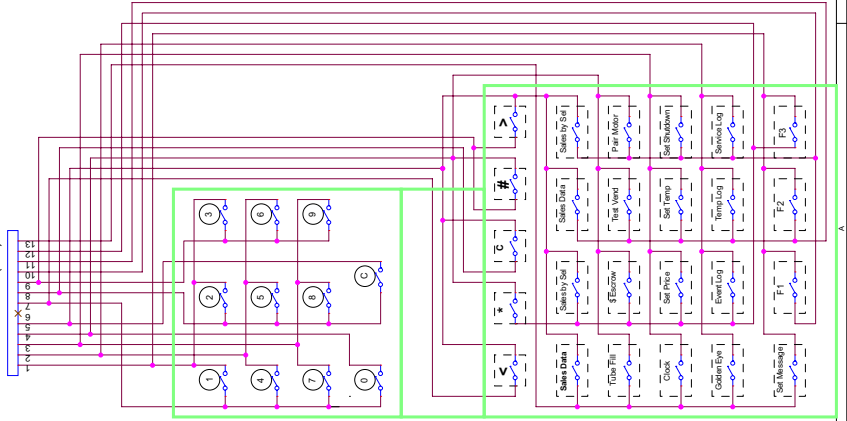

Part of 16800148-01

REV	TITLE	REVISION NUMBER	REVISION DESCRIPTION	BY	DATE	DESIGNED	CHECKED
1	965 Machine Diagrams						

TOLERANCES (EXCEPT AS NOTED)	UNLESS OTHERWISE SPECIFIED
FRACTIONS	AS SHOWN
DECIMALS	±0.005
HOLE DEC.	+0.000
ANGLES	±0.002

DATE	DRAWN BY	CHECKED BY
9-23-2005	Jeff C. Hudson	S Hudson

SHEET	SIZE	PART NUMBER	REV
1	OF 1	17600016	A

DO NOT SCALE DRAWING

965 Machine Diagrams

THIS DOCUMENT CONTAINS INFORMATION WHICH IS PROPRIETARY TO CROSS-GIVEN. REPRODUCTION OF THIS DOCUMENT WITHOUT THE WRITTEN APPROVAL OF CROSS-GIVEN IS STRICTLY PROHIBITED.

Cross-Given Mfg Co
 17100001
 St. Paul, MN 55107

