

TABLE OF CONTENTS

GENERAL INFORMATION	Page 1
To Order by Mail	1
To Order by Fax Machine	1
To Order by Phone	1
Returns	1
Limitation of Liability	1
FINAL ASSEMBLY	2,3
STYLING CONFIGURATION	4,5
DOOR ASSEMBLY	6,7
TENSION SPRING ASSEMBLY	8
WINDOW LATCH ASSEMBLY	8
LIGHT ASSEMBLY	9
MECH PLATE ASSEMBLY	10,11
COMMON CABINET ASSEMBLY	12,13
POWER PANEL ASSEMBLY	14
STACK RACK ASSEMBLY	15
BUCKET CONFIGURATION	15
STACK ASSEMBLY	16,17
REFRIGERATION ASSEMBLY	18,19

GENERAL INFORMATION:

Welcome to VendNet, Inc., we offer you three convenient ways to order replacement parts. If you have any questions when placing your order, please call and we'll be happy to assist you. Please provide the following information when placing your order:

Quantity Required
Part Number
Shipping and Billing Address
Description
Preferred Method of Shipment
Vendor Model Number
Customer Account Number
Serial Number

- MINIMUM ORDER \$25.00. You may wish to inquire on prices of parts at the time of your order. If you order less than the minimum, please check our catalog for other parts you may require to bring your order up to the \$25.00 minimum order.
- OPEN ACCOUNT with approved credit.
- MASTER CARD - VISA - C.O.D.

If you have any questions, please call and we will be happy to assist you.

TO ORDER BY MAIL:

You may place your requirements for replacement parts by providing the necessary information as requested above, and mailing your order to:

VendNet, Inc.
P.O. Box 488
165 North 10th Street
Waukee, Iowa 50263-0488

If you have any questions, call (800-833-4411), ask for VendNet Parts and we will be happy to assist you.

Order forms are available upon request from VendNet, Inc. Or you may use your own purchase order form.

TO ORDER BY FAX MACHINE:

(515) 987-4447

You may Fax your order for replacement parts by providing the necessary information as requested above to VendNet, Inc. By using our fax, **(515) 987-4447**.

TO ORDER BY E-MAIL:

You may E-MAIL your order for replacement parts by providing the necessary information as requested above to:

VENDNET@NETINS.NET

TO ORDER BY PHONE:

In the United States: 800-833-4411

In Canada: 800-858-4730

All Others: 515-274-3641

You may call in your order for replacement parts. Ask for VendNet Parts Department. Please provide the necessary information, as requested above, to allow us to provide you with prompt courteous service. If you have any questions, so indicate and we will be happy to assist you.

RETURNS:

RESTOCKING CHARGE 20%. A restocking charge of 20% will apply to merchandise accepted by VendNet for return, except items processed as warranty.

All items returned must be accompanied by a "material return tag" clearly stating the reason for return. Returns are to be shipped freight prepaid to VendNet, Inc., 165 North 10th Street, Waukee, Iowa 50263-0488. (Return tags are available upon request from VendNet.)

If you have any questions regarding returns, please call VendNet, Inc.

LIMITATION OF LIABILITY:

VendNet, Inc. Shall not be liable for any injury, loss or damage, whether direct, incidental or consequential arising out of the use of or the inability to use any part, parts or products sold by VendNet, Inc. The remedies of the buyer set forth herein are exclusive, and the liability of VendNet, Inc. With respect to any contract or sale or anything done in connection herewith, whether in connection therewith, whether in contract, in tort, under any warranty, or otherwise, shall not, except as expressly provided herein, exceed the price of the part, parts or products on which such liability is based. Any statements or representations about the parts or product, other than those contained herein, do not constitute warranties and shall not be relied on by the buyer and shall have no force of effect unless contained in a written agreement signed by officers of VendNet.

FINAL ASSEMBLY

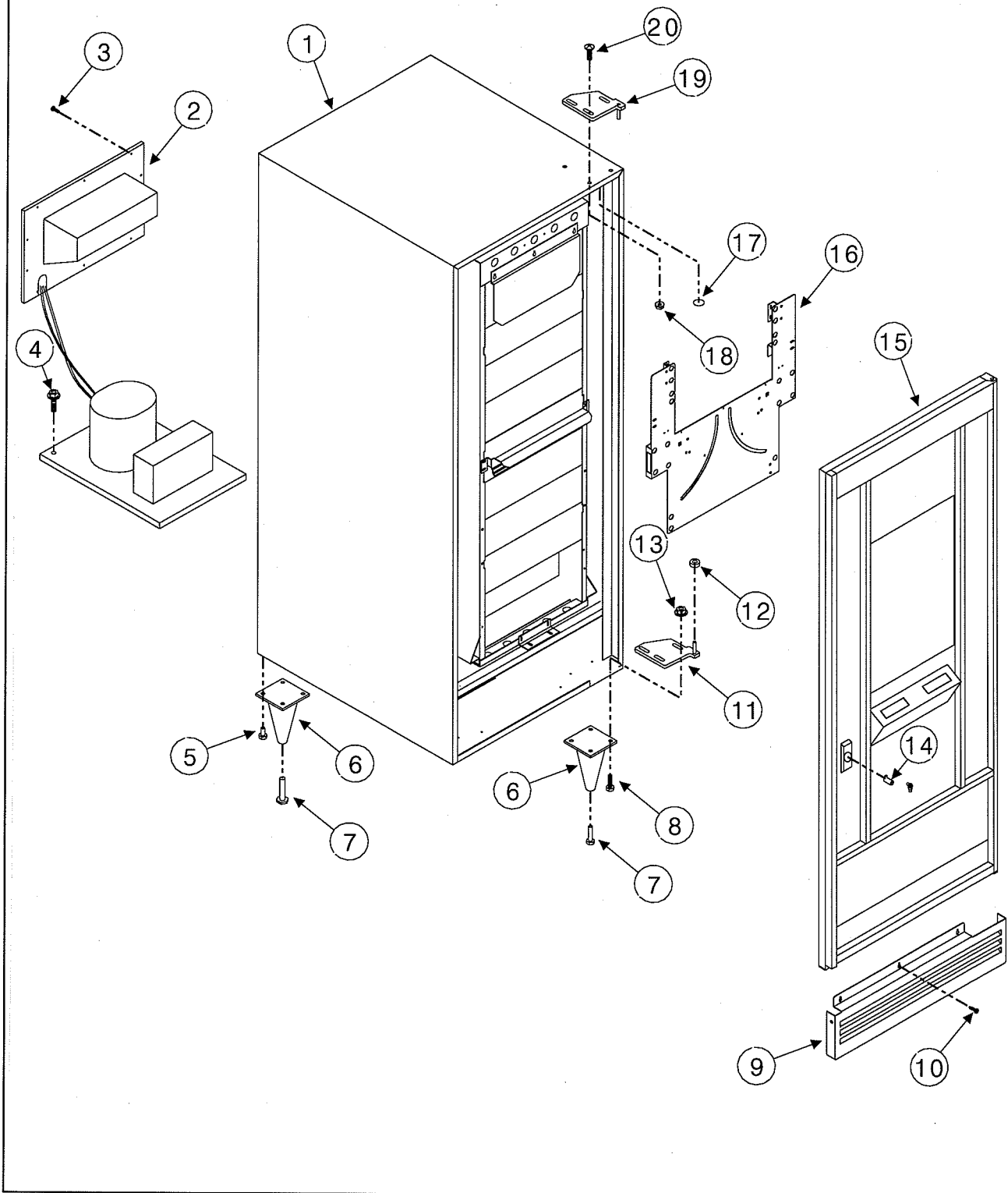

FINAL ASSEMBLY

ITEM	PART NUMBER	QTY	DESCRIPTION
1	1212648	1	CABINET ASSEMBLY (SEE PAGE #12)
2	1130814-010	1	REFER ASSEMBLY, R134A, 115V (SEE PAGE #18)
	1130814-011	1	REFER ASSEMBLY, R134A, 230V (SEE PAGE #18)
3	8800638	12	#10-16 X 3/8 PHIL PH TYPE AB
4	8801388	2	#5/16-18 X 3/4 HWH TYPE D
5	8801388	12	#5/16-18 X 3/4 HWH TYPE D
6	1131275	4	LEG WELD
7	8363374	4	LEG LEVELER
8	4201385	4	#5/16-18 X 1 HEX HEAD THREAD ROLLER
9	4206133	1	KICK PANEL
10	8800636	3	#8-18X1/2 PHIL PH TYPE B
11	1212653-003	1	HINGE WELD - BOTTOM
12	4050767	1	3/8 NYLON SPACER
13	8810015	3	#5/16-18 FLANGE LOCK NUT
14	4060330-xxx	1	LOCK CYLINDER WITH KEYS (OPTIONAL)
15	1212647	1	DOOR ASSEMBLY (SEE PAGE #6)
16	1214102	1	MECH DOOR/PLATE ASSEMBLY (50/50 SPLIT), (SEE PAGE # 10)
17	7250135-002	1	1" HOLE PLUG
18	8810015	3	#5/16-18 FLANGE LOCK NUT
19	1212653-004	1	HINGE WELD - TOP
20	8810013	3	#5/16-18 X 1 CARRIAGE BOLT

PARTS FURNISHED IN SERVICE PACKET

	1211234	2	TIE PLATE ASSEMBLY
	4201342	1	SCREWDRIVER
	4206640	100	PINE TREE CLIP
	4206945	40	BUCKET EDGE RETAINER
	4207581	80	PUSH-IN RETAINER
	4207310	1	SERVICE MANUAL (MODEL 3079-C)
	4206143	1	SERVICE MANUAL (MODEL 3079-V)

OPTIONAL KITS & ACCESSORIES

	7202038-000	1	CUSTOM LOCK CYLINDERS (CODED TO CUSTOMER SPECS.)
--	-------------	---	--

STYLING CONFIGURATION

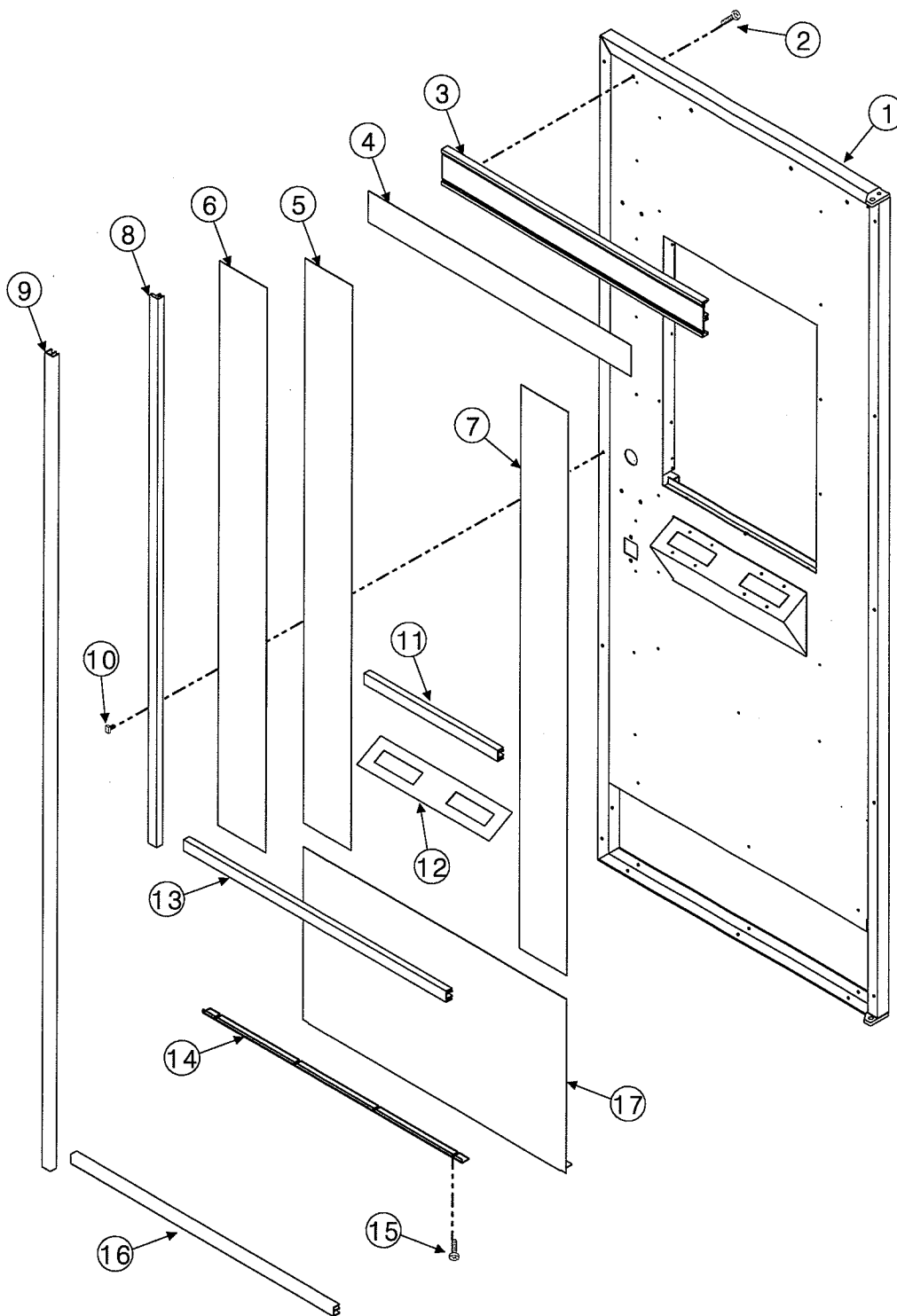

STYLING CONFIGURATION

ITEM	PART NUMBER	QTY	DESCRIPTION
1	1212620	1	DOOR WELD
2	8800638	6	#10-16 X 3/8 PHL PH TYPE "B" (FOR ITEM 3)
3	4202050-007	1	HEADER TRIM
4	4201119-141	1	HEADER PANEL - PRESIDENTIAL WALNUT
	4201119-145	1	HEADER PANEL - STERLING ROYCE
	4201119-145	1	HEADER PANEL - PEWTER
	4201119-153	1	HEADER PANEL - GENESIS
	4201119-145	1	HEADER PANEL - TRON
5	4206234-001	1	LEFT SIDE STYLING PANEL
6	4205958	1	INSTRUCTION DECAL
7	4206234-002	1	RT SIDE STYLING PANEL - PRESIDENTIAL WALNUT
	4206234-044	1	RT SIDE STYLING PANEL - STERLING ROYCE
	4206234-047	1	RT SIDE STYLING PANEL - PEWTER
	4206234-050	1	RT SIDE STYLING PANEL - GENESIS
	4206234-053	1	RT SIDE STYLING PANEL - TRON
8	4205979-004	2	SNAP-ON TRIM (WINDOW SIDES)
9	4205979	2	SNAP-ON TRIM - PRESIDENTIAL WALNUT (SILVER)
	4205979	2	SNAP-ON TRIM - STERLING ROYCE (SILVER)
	4205979-001	2	SNAP-ON TRIM - PEWTER (BLACK)
	4205979-001	2	SNAP-ON TRIM - GENESIS (BLACK)
	4205979-001	2	SNAP-ON TRIM - TRON (BLACK)
10	4201116	32	10 X 5/16 TRIM HD SMS (FOR ITEMS 8, 9, 13, & 16)
11	8383670-047	1	TRIM-DISPLAY-OUTER
12	4206584	1	DISPLAY DECAL - PRICING
13	4206440	1	SNAP-ON TRIM
14	8620455-005	1	LOWER DOOR TRIM
15	8800636	4	#8-18 X 1/2 PHIL PH TYPE "B" (FOR ITEM 14)
16	4201117-075	1	SNAP-ON TRIM - PRESIDENTIAL WALNUT (SILVER)
	4201117-075	1	SNAP-ON TRIM - STERLING ROYCE (SILVER)
	4201117-076	1	SNAP-ON TRIM - PEWTER (BLACK)
	4201117-076	1	SNAP-ON TRIM - GENESIS (BLACK)
	4201117-076	1	SNAP-ON TRIM - TRON (BLACK)
17	4206958-001	1	OVERLAY PANEL - PRESIDENTIAL WALNUT
	4206958-015	1	OVERLAY PANEL - STERLING ROYCE
	4206958-016	1	OVERLAY PANEL - PEWTER
	4206958-017	1	OVERLAY PANEL - GENESIS
	4206958-018	1	OVERLAY PANEL - TRON

A/R = As Required

DOOR ASSEMBLY

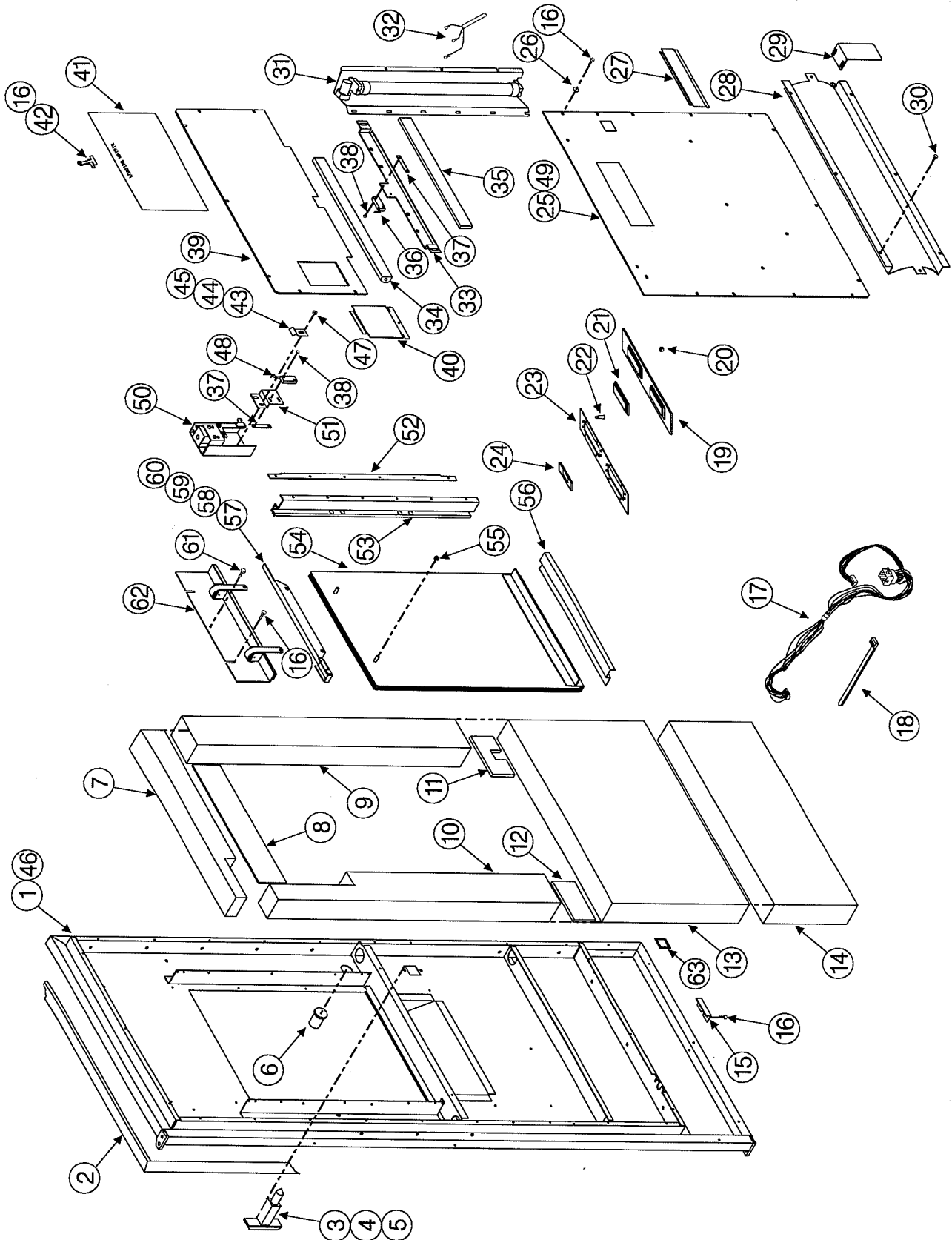

DOOR ASSEMBLY

ITEM	PART NUMBER	QTY	DESCRIPTION
1	1212620	1	DOOR WELD
2	4201203-003	1	DOOR GASKET
3	4203486	1	1/4 TURN HANDLE
4	4050338	2	#10-32 X 1/2 PHIL FH MS
5	8800952	2	#10-32 HEX NUT W/EXT TOOTH LOCKWASHER
6	4203703-001	1	SHOPPER BUTTON
7	4206141-001	1	TOP DOOR INSULATION(A)
8	4201510-001	1	UPPER DOOR INSULATOR
9	4206141-003	1	TOP DOOR INSULATION(C)
10	4206141-002	1	TOP DOOR INSULATION(B)
11	4206950	1	INSULATION FILLER W/NOTCH
12	4206950-001	1	INSULATION FILLER W/OUT NOTCH
13	4206942	1	MIDDLE DOOR INSULATION
14	4206142	1	BOTTOM DOOR INSULATION
15	4206951	1	DOOR HARNESS RETAINER
16	8800636	46	#8-18 X 1/2 PHIL PH TYPE B
17	4206999	1	DOOR HARNESS
18	4033712	1	CABLE TIE 7 3/8"
19	4206589	1	DISPLAY BOARD, COINCO (MODEL 3079-C)
	4206977	1	DISPLAY BOARD,VERSATILE (MODEL 3079-V)
20	4050505	8	#6-32 TWIN WHIZ LOCK NUT
21	4200659	2	READOUT WINDOW
22	4206879	8	BOARD STAND OFF
23	4206588	1	LENS HOLD DOWN
24	4207392	2	DISPLAY BLOCK DECAL
25	4205910	1	LOWER DOOR LINER
26	8801011	23	#8 FLAT WASHER
27	4207559	1	DISPLAY BOARD ACCESS
28	4206620	1	SCREEN
29	4206532	1	SWITCH ACTUATOR
30	8800638	14	#10-16 X 3/8 PHIL PH SMS TYPE B
31	1212659-001	1	LIGHT ASSEMBLY - LEFT (SEE PAGE # 9)
	1212659-002	1	LIGHT ASSEMBLY - RIGHT (SEE PAGE # 9)
32	4207027	1	LAMP POWER HARNESS
33	4207558	1	SWITCH MOUNT
34	4207723	1 FT	WINDOW GASKET
35	4202255	1 FT	GASKET W/ADHESIVE, 1/4" X 3/4"
36	4207512	1	VEND DOOR SENSE SWITCH
37	8337588-1	2	#4-40 TWIN SPRING NUT
38	4050004	4	#4-24 X 3/4 PHIL PH TYPE AB
39	4205911	1	UPPER DOOR LINER
40	4206492	1	LATCH ACCESS
41	4207264	1	LOADING MATRIX
42	4060118	1	BULL DOG CLIP
43	4207554	1	HEATER WIRE RETAINER
44	7334795-004	1	HEATER WIRE - 115 VOLT (NOT SHOWN)
44	7334795-005	1	HEATER WIRE - 230 VOLT (NOT SHOWN)
45	4207474	2	HEATER WIRE PLUG ENDS (NOT SHOWN)
46	4206939	1	TILT LABEL (NOT SHOWN)
47	8800956	2	#8-32 HEX NUT W/EXT WASHER
48	4201971	1	SWITCH 90 DEGREES
49	4200032-000	1	LABEL - MADE IN USA (NOT SHOWN)
50	1212773	1	WINDOW LATCH ASSEMBLY (SEE PAGE # 8)
51	4207092	1	SWITCH MOUNT
52	4206266	2	EXTRUSION MOUNT ANGLE
53	4205864	2	WINDOW EXTRUSION
54	1212661	1	WINDOW ASSEMBLY
55	4050511	2	#8-32 TWO WAY LOCK NUT
56	4205865	1	WINDOW LEDGE
57	1214142	1	WINDOW STOP WELD
58	4060005-500	2 FT	1/8" X 1/4" CLOSED CELL TAPE
59	4202256	1.1 FT	EDGE GUARD
60	4202777	A/R	DOUBLE FACE TAPE - 1/2"
61	4050180	1	#8-18 X 1/2 PHIL PH TEK
62	1212658	1	TENSION SPRING ASSEMBLY (SEE PAGE #8)
63	4200238	1	SELF ADHESIVE FEET

A/R = As Required

TENSION SPRING ASSEMBLY

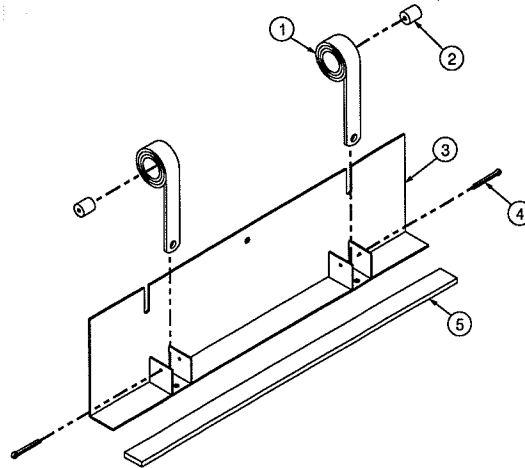

ITEM	PART NUMBER	QTY	DESCRIPTION
1	4202483-004	2	SPRING, CONSTANT FORCE
2	4203845	2	PUSHER BEARING
3	1212619	1	TENSION SPRING WELD
4	4203723	2	COTTER PIN, 3/32 X 1"
5	4202255	1.2 FT	GASKET W/ADHESIVE, 1/4" X 3/4"

WINDOW LATCH ASSEMBLY

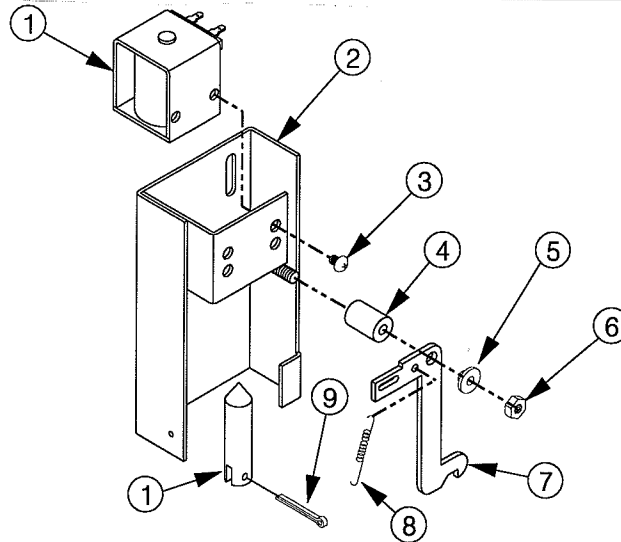

ITEM	PART NUMBER	QTY	DESCRIPTION
1	4205908	1	SOLENOID - 24VDC
2	1212774	1	WINDOW LATCH WELD
3	8800246	2	#10-32 X 1/4 PHIL TH MS
4	4030097	1	SPACER
5	4030053	1	SHOULDER BUSHING
6	4050511	1	#8-32 TWO WAY LOCK NUT
7	4206271	1	WINDOW LATCH
8	8377723	1	RETURN SPRING
9	4203723	1	COTTER PIN, 3/32" X 1"

LIGHT ASSEMBLY

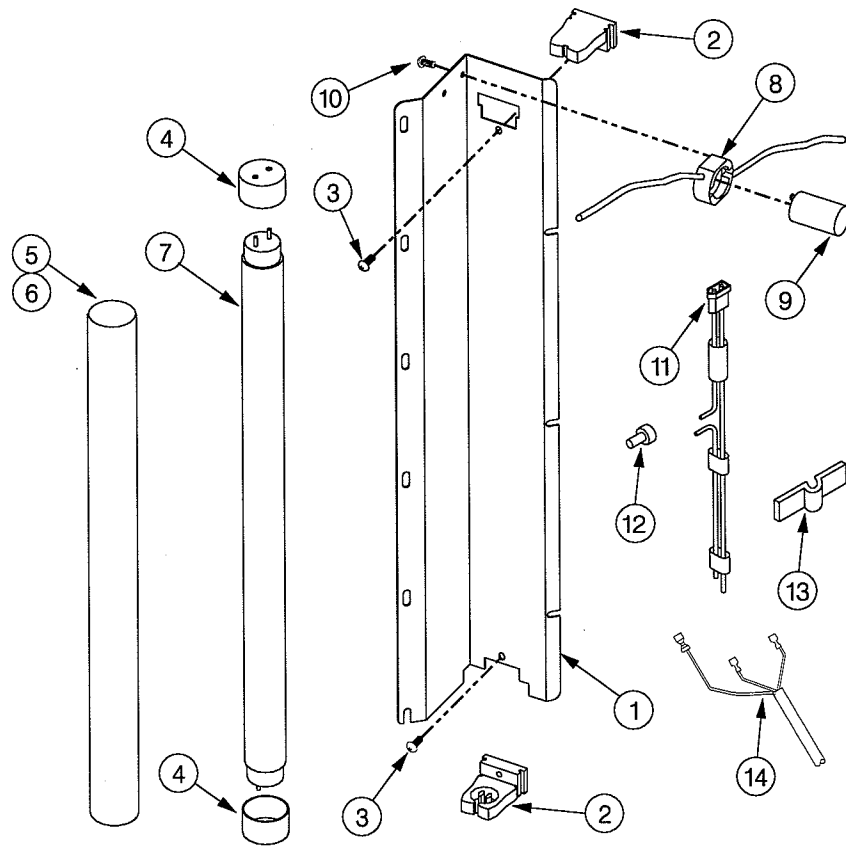

ITEM	PART NUMBER	QTY	DESCRIPTION
	1212659-001	1	LIGHT ASSEMBLY - LEFT
	1212659-002	1	LIGHT ASSEMBLY - RIGHT
1	4205874-002	1	LIGHT MOUNT - LEFT
	4205874-004	1	LIGHT MOUNT - RIGHT
2	4033548	2	FLUORESCENT LAMP HOLDER
3	4050113	2	#6-32 X 1/2 PHIL PH MS
4	4033713-003	2	END CAP, SAFETY SHIELD
5	4025764	1	SAFETY TUBE
6	4060622	A/R	FILAMENT TAPE
7	4033549	1	FLUORESCENT LAMP - 18"
8	4033617	1	STARTER SOCKET
9	4033567	1	STARTER FS-2
10	8800024	2	#4-40 X 3/8 PHIL PH MS
11	4206516	1	LIGHT HARNESS
12	4033505	1	CLOSED END SPLICE CAP
13	4060130	2	PRESS CLIP - 1/4"
14	4207027	1	LAMP POWER HARNESS

MECH PLATE ASSEMBLY

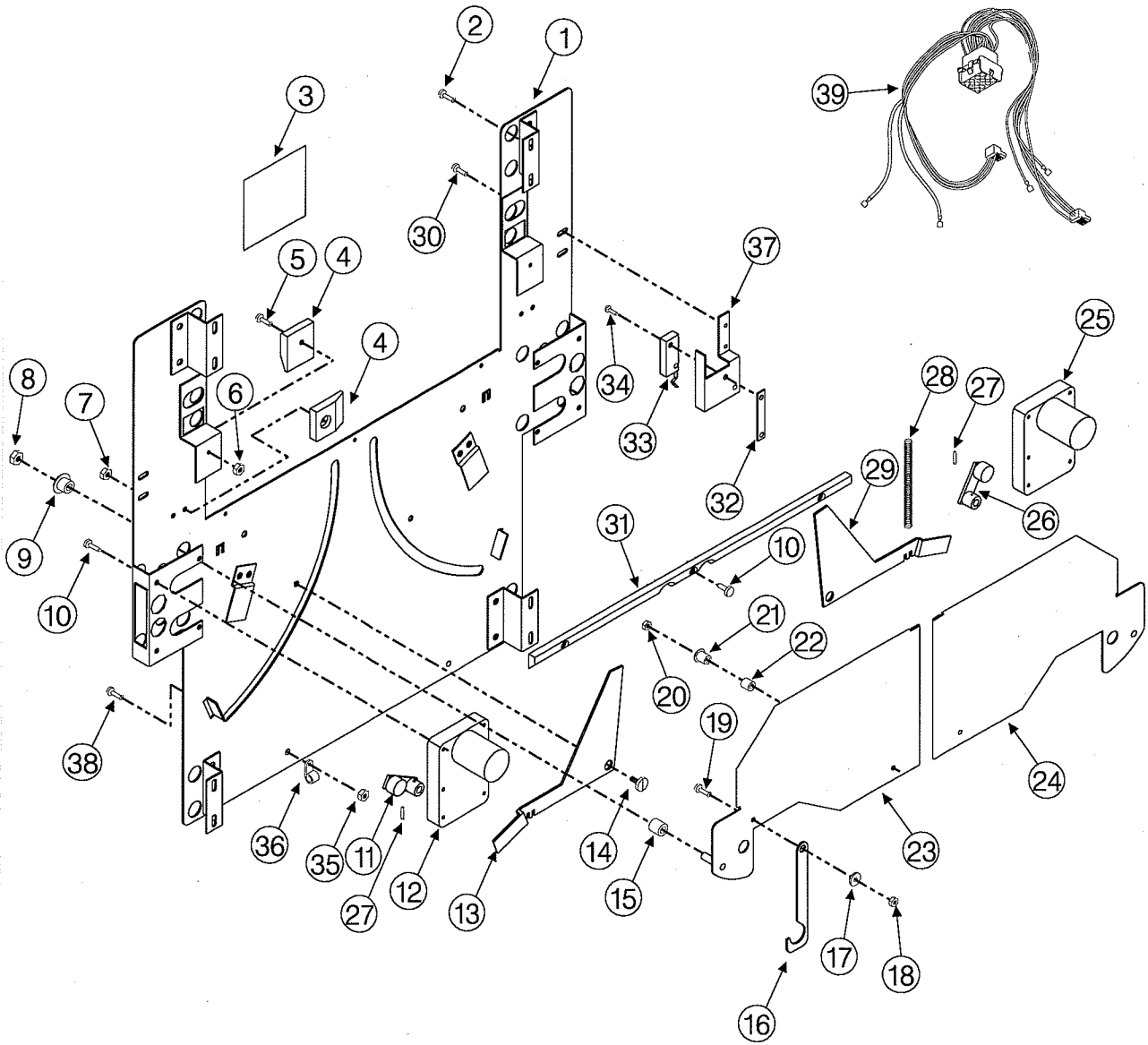

MECH PLATE ASSEMBLY

ITEM	PART NUMBER	QTY	DESCRIPTION
	1214102		MECH PLATE ASSEMBLY (50/50 SPLIT BUCKET)
1	1212977	1	MECH PLATE WELD
2	8800636	8	#8-18 X 1/2 PHIL PH TYPE B
3	4207566	1	MECH PLATE WARNING LABEL
4	4025610	4	DOOR GLIDE
5	4050240	4	#8-32 X 3/8 PHIL PH MS
6	4050511	4	#8-32 TWO WAY LOCK NUT
7	8800882	2	#10-24 NUT W/NYLON INSERT
8	4050496	2	1/4-20 TWO WAY LOCK NUT
9	4207348	2	DOOR SPACER
10	8800636	11	#8-18 X 1/2 PHIL PH TYPE B
11	1214110-001	1	LEVER STAKE - RIGHT
12	4207394-002	1	SPLIT DOOR MOTOR - RIGHT, (CCW)
13	4207354-004	1	RELEASE LEVER - RIGHT
14	8368294	2	#10-24 X 21/64 SHOULDER SCREW
15	4207353	2	DOOR WASHER
16	4207583	2	RELEASE CATCH
17	4030100	2	BUSHING - SPACER
18	4050511	2	#8-32 TWO WAY LOCK NUT
19	4050240	2	#8-32 X 3/8 PHIL PH MS
20	4050511	2	#8-32 TWO WAY LOCK NUT
21	4207349	2	DOOR BUSHING
22	4207352	2	DOOR SPACER
23	1212978-002	1	DOOR STAKE - RIGHT, (50/50 SPLIT)
24	1212978-001	1	DOOR STAKE - LEFT, (50/50 SPLIT)
25	4207394-001	1	SPLIT DOOR MOTOR - LEFT (CW)
26	1214110-002	1	LEVER STAKE - LEFT
27	8801393	2	SPRING PIN, 3/32" X 1/2"
28	4021042	2	RELEASE SPRING
29	4207354-003	1	RELEASE LEVER - LEFT
30	4050423	4	#8-18 X 3/8 PHIL PH TYPE AB
31	4207384	1	RAMP
32	8337588-1	2	#4-40 TWIN SPRING NUT
33	4201971	2	SWITCH 90 DEGREES
34	4050004	4	#4-24 X 3/4 PHIL PH SMS TYPE AB
35	4050511	2	#8-32 TWO WAY LOCK NUT
36	8324099-2	2	1/4" WIRE CLAMP
37	4207501-001	1	SPLIT SWITCH MOUNT - RIGHT (NOT SHOWN)
	4207501-002	1	SPLIT SWITCH MOUNT - LEFT
38	4050240	2	#8-32 X 3/8 PHIL PH MS
39	4206524	1	MECH HARNESS

CABINET ASSEMBLY

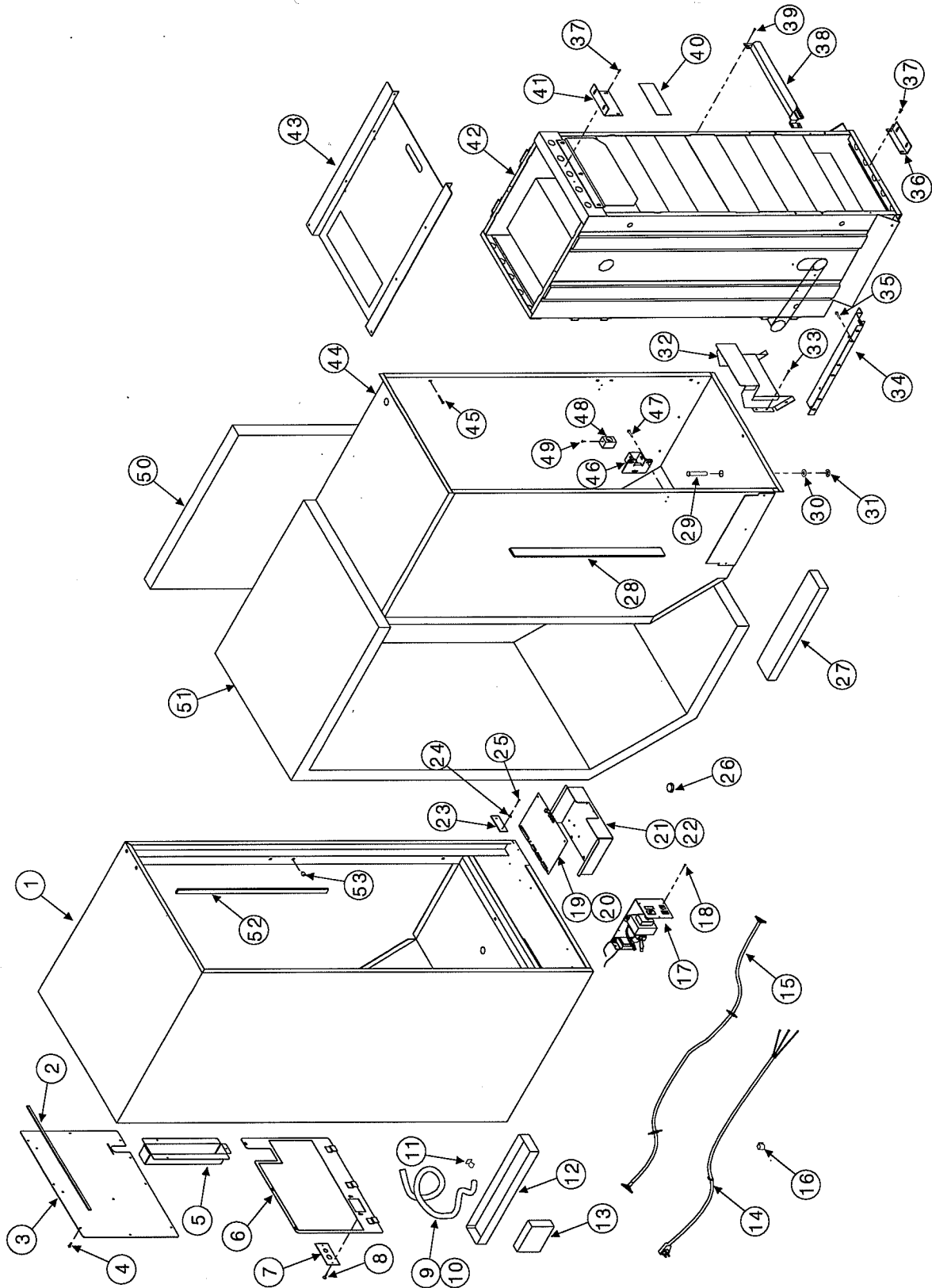

CABINET ASSEMBLY

ITEM	PART NUMBER	QTY	DESCRIPTION
1	1212625	1	CABINET WELD
2	4060006-500	16 FT	1/4" X 1/2" FOAM TAPE
3	4205900	1	CABINET BACK COVER
4	4050792	13	#10-16 X 1/2" PHIL PH TYPE B
5	4205901	1	SUCTION LINE COVER
6	1212628	1	BACK SCREEN WELD
7	4206405	1	CORD PLATE
8	8800636	2	#8-18 X 1/2" PHIL PH TYPE B
9	4025410-500	2FT	TUBING, MAYON
10	4033712	1	CABLE TIE 7 3/8"
11	7200341-000	1	TUBE CLIP
12	7200623-000	1	DRAIN PAN
13	4202034	1	DRAIN PAN SPONGE
14	4033631-005	1	POWER CORD - 115V (DOMESTIC)
	4202512-002	1	POWER CORD - 230V (NON-DOMESTIC)
15	4207002	1	UMBILICAL HARNESS - COINCO (MODEL 3079-C)
	4207266	1	UMBILICAL MDB HARNESS - VERSATILE (MODEL 3079-V)
16	8370959-3	1	3/4" LOCKING CLAMP
17	1212929	1	POWER PANEL ASSEMBLY - 115V, (SEE PAGE # 14)
	1212929-240	1	POWER PANEL ASSEMBLY- 230V, (SEE PAGE # 14)
18	4050423	3	#8-18 X 3/8" PHIL PH TYPE AB
19	4206134	1	CONTROL BOARD - COINCO (MODEL 3079-C)
	4206976	1	CONTROL BOARD - VERSATILE (MODEL 3079-V)
20	4207000	1	CONTROLLER HARNESS - COINCO (MODEL 3079-C)
	4207000-001	1	CONTROLLER HARNESS - VERSATILE (MODEL 3079-V)
21	4206304	1	CONTROLLER MOUNT
22	4025723	A/R	CONTROLLER STAND-OFF
23	4206881	1	HARNESS SHROUD
24	8801011	2	#8 FLAT WASHER
25	4050180	2	#8-18 X 1/2" PHIL PH TEK
26	7250135-000	2	1-3/8" HOLE PLUG
27	4201398	2	WOOD LINER SUPPORT
28	4202278	13.6 FT	1.562 WIDE X 1/4" FOAM TAPE
29	7100042-000	1	DRAIN TUBE
30	4050608	1	1/2" FLAT WASHER
31	4202284	1	.500 STUD PUSH NUT
32	1214195	1	AIR SCOOP WELD
33	4050423	6	#8-18 X 3/8 PHIL PH TYPE AB
34	1212622	2	FRAME SLIDE WELD
35	8800638	6	#10-16 X 3/8 PHIL PH TYPE B
36	4206311	1	BOTTOM HOLD DOWN
37	8800538	4	#8-18 X 1/2" PHIL TH W/ETW TYPE AB
38	1214101	1	BUCKET ANTI-THEFT
39	4050423	4	#8-18 X 3/8 PHIL PH TYPE AB
40	4207737	1	NOTICE DECAL
41	4206312	1	TOP HOLD DOWN
42	1212655	1	STACK ASSEMBLY (SEE PAGE #16)
43	1212878	1	STACK RACK ASSEMBLY (SEE PAGE #15)
44	1212626	1	LINER WELD
45	7200468-001	12	#10-12 X 1" PHIL TH TYPE A
46	1212631	1	LOCK BRACKET WELD
47	4201239	1	1/4"-20 X 3/4" HWH TAPTITE
48	4203634	1	SPLIT NUT ASSEMBLY
49	8800638	2	#10-16 X 3/8" PHIL PH TYPE B
50	8382690-001	2	CABINET SIDE INSULATION
51	8382689-001	1	CABINET INSULATION
52	7960247-000	12 FT	"A" FRAME GASKET
53	4202189	12	SNAP IN PLASTIC SPRING NUT, 1/4"

A/R = As Required

POWER PANEL ASSEMBLY

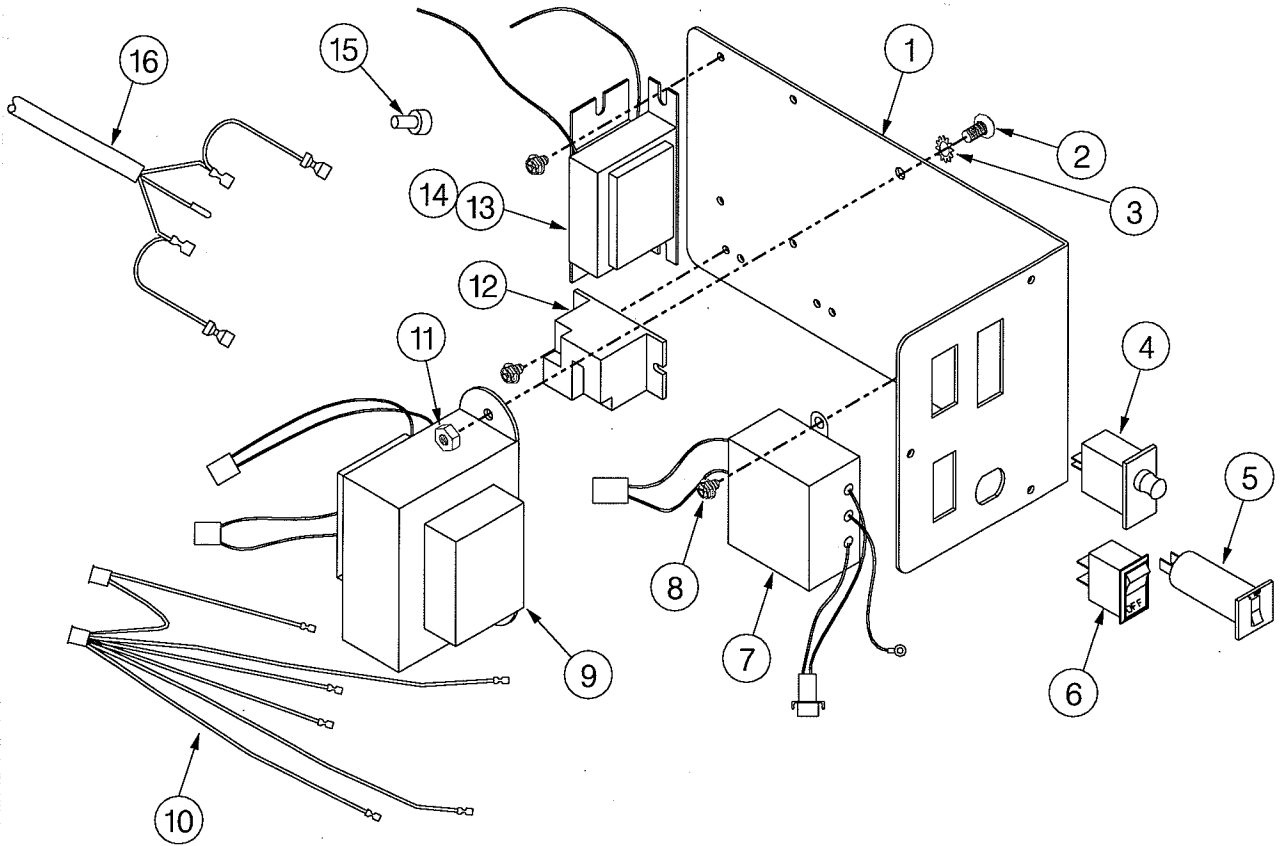

ITEM	PART NUMBER	QTY	DESCRIPTION
	1212929		POWER PANEL ASSEMBLY - 115 VOLT
	1212929-240		POWER PANEL ASSEMBLY - 230 VOLT
1	4206768	1	POWER PANEL
2	4050240	2	#8-32 X 3/8 PHIL PH MS
3	4050585	2	#8 EXTERNAL TOOTH LOCKWASHER
4	8361630-001	1	INTERLOCK SWITCH
5	4203467-003	1	3 AMP CIRCUIT BREAKER
6	4202088	1	ROCKER SWITCH
7	4203730-003	1	RFI FILTER
8	4050420	8	#8-18 X 1/4" PHIL HWH SMS
9	4206570-000	1	TRANSFORMER - 115 VOLT
9	4206570-001	1	TRANSFORMER - 230 VOLT
10	4207023	1	TRANSFORMER HARNESS
11	8800956	2	#8-32 HEX NUT W/ETW
12	4206531	1	COMPRESSOR RELAY
13	4033609	2	BALLAST - 115 VOLT
	4033074	2	BALLAST - 230 VOLT
14	4033712	2	CABLE TIE 7 3/8"
15	4033505	4	CLOSED END SPLICE CAP
16	4207020	1	POWER HARNESS

STACK RACK ASSEMBLY

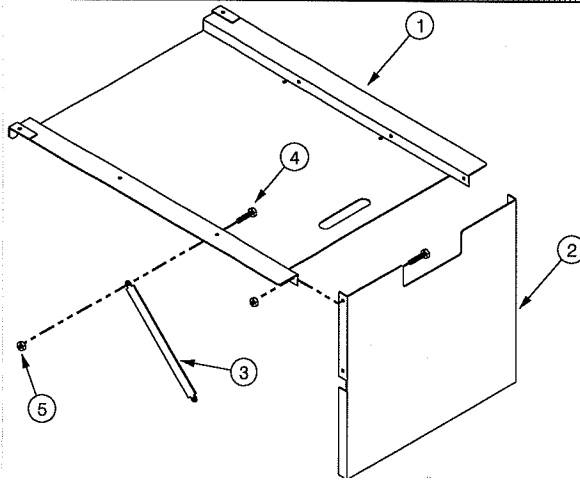

ITEM	PART NUMBER	QTY	DESCRIPTION
	1212878		STACK RACK ASSEMBLY
1	1212877	1	SLIDE TOP WELD
2	4206821	1	STACK SLIDE BOTTOM
3	4206824	2	STACK SLIDE LINK
4	8800429	6	1/4-20 X 3/4 PHIL HH W/ETW
5	4050547	6	1/4-20 TWIN WHIZ NUT

BUCKET CONFIGURATION

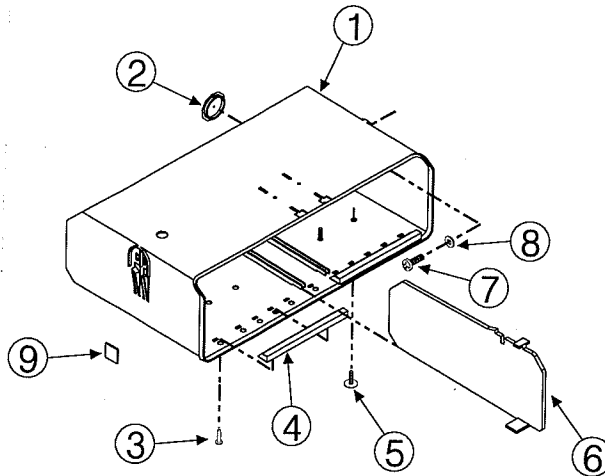

ITEM	PART NUMBER	QTY	DESCRIPTION
1	4205857	20	BUCKET
2	7250135-002	1	HOLE PLUG, 1" (ONE BUCKET ONLY - HOME SWITCH)
3	4207581	80	PUSH-IN RETAINER
4	4206945	40	BUCKET EDGE RETAINER
5	4206640	100	PINE TREE CLIP
6	4205859	20	BUCKET DIVIDER
7	4201330	40	#8-32 X 3/8 TAMPER PROOF SCREW
8	8801011	40	#8 FLAT WASHER
9	4207555-001	A/R	INDICATOR LABEL "J"
	4207555-002	A/R	INDICATOR LABEL "L"

STACK ASSEMBLY

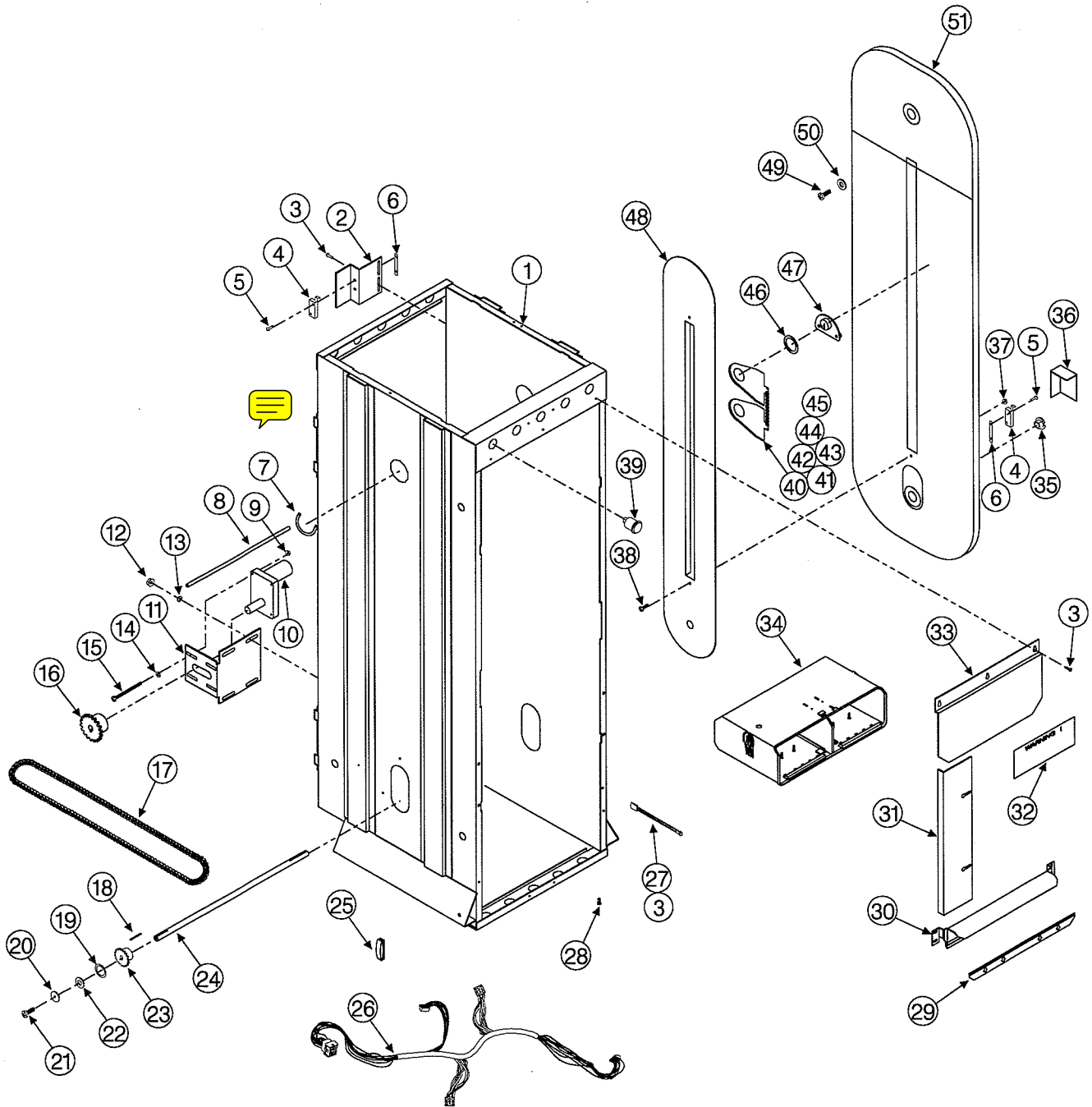

STACK ASSEMBLY

ITEM	PART NUMBER	QTY	DESCRIPTION
1	1212601	1	STACK WELD
2	4206119	1	HOME SWITCH BRACKET
3	4050423	15	#8-18 X 3/8" SMS PHIL PH TYPE AB
4	4207512	2	SENSE SWITCH
5	4050004	4	#4-24 X 3/4" PHIL PH TYPE AB SMS
6	8337588-1	2	#4-40 TWIN SPRING NUT
7	8382684	2	7/8" SNAP RING
8	4205890	1	SPACER SHAFT
9	8800956	4	#8-32 HEX NUT W/ETW
10	4207481	1	STACK MOTOR ASSEMBLY
11	4206125	1	MOTOR MOUNT
12	4050531	4	1/4"-20 HEX NUT
13	4050593	4	1/4" EXT TOOTH LOCKWASHER
14	8801011	4	#8 FLAT WASHER
15	8800088	4	#8-32 X 2" PHIL PH MS
16	4201075-002	5	SPROCKET-CONVEYOR - LARGE
17	8382686-001	1	CHAIN
18	8382778	4	SQUARE KEY
19	4201206	4	7/8" NYLON WASHER
20	8330213-001	2	#10 FENDER WASHER
21	8800364	5	#10-24 X 1/2" PHIL PH MS
22	4008694-001	5	9/16" WASHER
23	4202008	1	CONVEYOR SPROCKET - SMALL
24	4205895	1	DRIVE SHAFT
25	4207217	8	FLAT WIRE CLAMP
26	4206529	1	STACK HARNESS
27	4201920-001	1	THERMISTOR ASSEMBLY
28	4205329	8	ARROW CLIP
29	4206583	1	VEND POSITION DECAL
30	1214101	1	BUCKET ANTI-THEFT
31	4206318	2	LIGHT REFLECTOR
32	4207737	1	NOTICE DECAL
33	4206124	1	STACK DOOR
34	4205857	20	BUCKET (SEE PAGE #15)
35	8382687	1	CAM (VEND POSITION)
36	4201740	1	CARRIER SWITCH COVER
37	8800952	4	#10-32 HEX NUT W/ETW
38	8800686	4	#10-32 X 1-1/2 PHIL PH TYPE -D MS
39	4203703-000	1	SELECTION SWITCH
40	1130740	2	CARRIER CHAIN ASSEMBLY
41	1130674	20	ARM CARRIER ASSEMBLY
42	8382401	20	CHAIN ROLLER
43	8382532	20	SPRING CLIP
44	8382533	20	CONNECTING LINK
45	8382533-001	20	CONNECTING LINK PLATE
46	8382602	40	SPACER
47	1130675	40	CARRIER ASSEMBLY
48	8382671-002	2	RETAINING PLATE
49	4201239	32	1/4"-20 X 3/4" HWH TAPTITE
50	8331913	32	.254 ID X 5/8" OD WASHER
51	1130738	2	TRACK & BUSHING ASSEMBLY

REFRIGERATION SYSTEM

EVAPORATOR ASSEMBLY

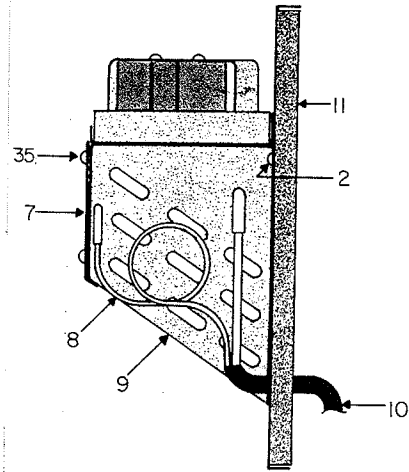
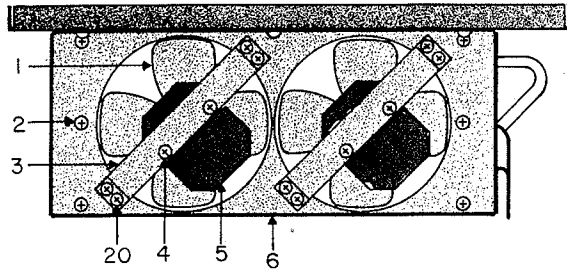

CONDENSER ASSEMBLY

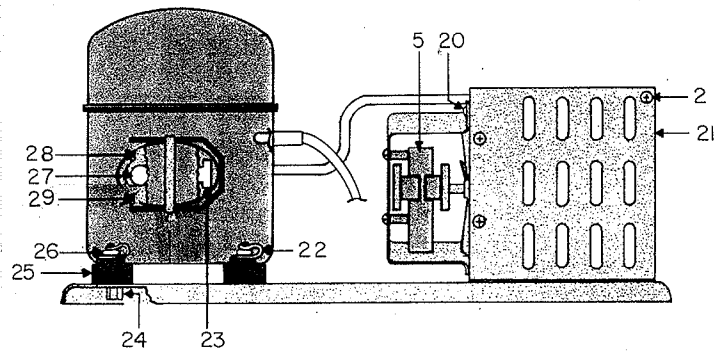
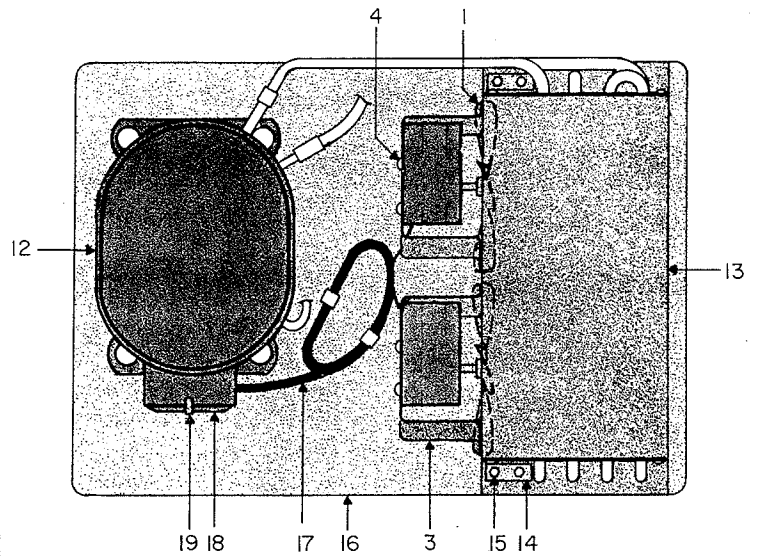
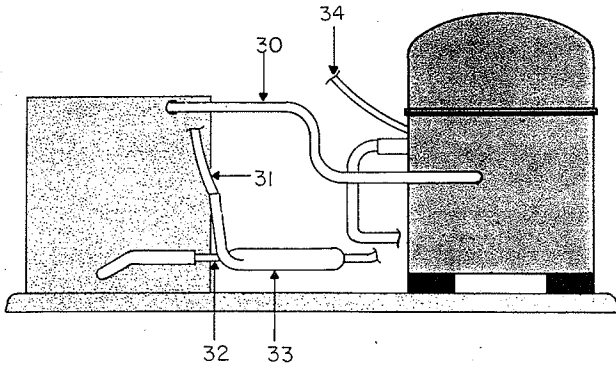

REFRIGERATION SYSTEM

ITEM	PART NUMBER	QTY	DESCRIPTION
	1130814-010	1	COMPLETE REFER SYSTEM - R134A - 115 VOLT
	1130814-011	1	COMPLETE REFER SYSTEM - R134A - 230 VOLT
1	4206498	4	FAN BLADE - ALUMINUM
2	8801204	14	#10-16 X 3/8 PHIL TH W/ETW
3	8382579	4	FAN BRACKET
4	8801204	8	#10-16 X 3/8 PHIL TH W/ETW
5	4206461	4	MOTOR -EVAPORATOR FAN (115 VOLT)
	4206461-001	4	MOTOR -EVAPORATOR FAN (230 VOLT)
6	8382581	1	ORIFICE - EVAPORATOR FAN
7	8382580	1	COVER - FRONT
8	1130657	1	HEATER EXCHANGE ASSY
9	8382295	1	EVAPORATOR
10	4206366-500	3 FT	INSULATION TUBING
11	1130824	1	MOUNTING BRACKET WELD ASSEMBLY
12	4203789	1	COMPRESSOR - 1/4 H.P. (115 VOLT)
	4205469	1	COMPRESSOR - 1/4 H.P. (230 VOLT)
13	8382293	1	SHROUD - CONDENSER FAN
14	8916923	2	1/4-20 TWIN SPRING NUT
15	7332393-000	4	1/4-20 X 3/8 SLTD HH MS
16	8343839	1	BASE PLATE - REFRIGERATION
17	4206607	1	REFRIGERATION HARNESS
18	8344308	1	COVER - TERMINAL
19	8344306	1	BALE STRAP
20	8801204	21	#10-16 X 3/8 PHIL TH W/ETW
21	8382294	1	CONDENSER
22	8343874	4	SPRING CLIP
23	8333894-8	1	STARTING RELAY (115 VOLT)
	8333894-10	1	STARTING RELAY (230 VOLT)
24	8800949	4	#3/8-16 HEX NUT W/ETW
25	8323090-1	4	GROMMET - COMPRESSOR
26	8343872	4	MOUNTING STUD
27	8045052-12	1	OVERLOAD PROTECTOR (115 VOLT)
	8045052-16	1	OVERLOAD PROTECTOR (230 VOLT)
28	8344305	1	SPRING - OVERLOAD
29	7200470-008	2	#6-32 X 3/16 PHIL RH TYPE K
30	8382297	1	LINE - DISCHARGE
31	8801180-003	2	1/4 COPPER TUBING - 6" LONG
32	8801180-002	1	1/4 COPPER TUBING - 3" LONG
33	4205468	1	DRIER - BONDED CORE
34	8801180-007	1	1/4 COPPER TUBING 8-1/4" LONG
35	4050663	4	RIVET
	4033704	3	CABLE TIE (NOT SHOWN)
	4033712	1	CABLE TIE 7 3/8" (NOT SHOWN)