

**CD-6SA**  
**STAND ALONE**  
**COLD DRINK VENDOR**  
**MODEL: 3061**

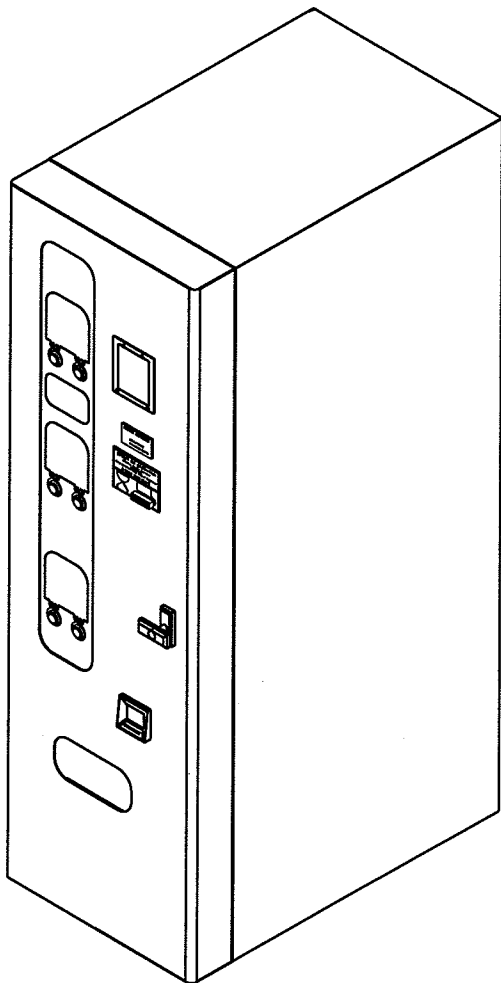

**PARTS**  
**MANUAL**

November 1995

P/N 4207435

## GENERAL INFORMATION:

Welcome to Selectivend, Inc., we offer you three convenient ways to order replacement parts. If you have any questions when placing your order, please call and we'll be happy to assist you. Please provide the following information when placing your order:

Quantity Required  
Part Number  
Shipping and Billing Address  
Description  
Preferred Method of Shipment  
Vendor Model Number  
Customer Account Number  
Serial Number

- **MINIMUM ORDER \$25.00.** You may wish to inquire on prices of parts at the time of your order. If you order less than the minimum, please check our catalog for other parts you may require to bring your order up to the \$25.00 minimum order.
- **OPEN ACCOUNT** with approved credit.
- **MASTER CARD - VISA - C.O.D.**

If you have any questions, please call and we will be happy to assist you.

## TO ORDER BY MAIL:

You may place your requirements for replacement parts by providing the necessary information as requested above, and mailing your order to:

Selectivend, Inc.  
P.O. Box 488  
165 North 10th Street  
Waukee, Iowa 50263-0488

If you have any questions, call **(800-833-4411)**, ask for Selectivend Parts and we will be happy to assist you. Order forms are available upon request from Selectivend, Inc. Or you may use your own purchase order form.

## TO ORDER BY FAX MACHINE:

**(515) 987-4447**

You may Fax your order for replacement parts by providing the necessary information as requested above to Selectivend, Inc. By using our fax, **(515) 987-4447**.

## TO ORDER BY PHONE: (800-833-4411)

You may call in your order for replacement parts. Ask for Selectivend Parts Department. Please provide the necessary information, as requested above, to allow us to provide you with prompt courteous service.

If you have any questions, so indicate and we will be happy to assist you.

## RETURNS:

**RESTOCKING CHARGE 20%.** A restocking charge of 20% will apply to merchandise accepted by Selectivend for return, except items processed as warranty.

All items returned must be accompanied by a "material return tag" clearly stating the reason for return. Returns are to be shipped freight prepaid to Selectivend, Inc., 165 North 10th Street, Waukee, Iowa 50263-0488. (Return tags are available upon request from Selectivend.)

If you have any questions regarding returns, please call Selectivend, Inc. (800-833-4411), we will be happy to assist you.

## LIMITATION OF LIABILITY:

Selectivend, Inc. Shall not be liable for any injury, loss or damage, whether direct, incidental or consequential arising out of the use of or the inability to use any part, parts or products sold by Selectivend, Inc. The remedies of the buyer set forth herein are exclusive, and the liability of Selectivend, Inc. With respect to any contract or sale or anything done in connection herewith, whether in connection therewith, whether in contract, in tort, under any warranty, or otherwise, shall not, except as expressly provided herein, exceed the price of the part, parts or products on which such liability is based. Any statements or representations about the parts or product, other than those contained herein, do not constitute warranties and shall not be relied on by the buyer and shall have no force of effect unless contained in a written agreement signed by officers of Selectivend.

# FINAL ASSEMBLY

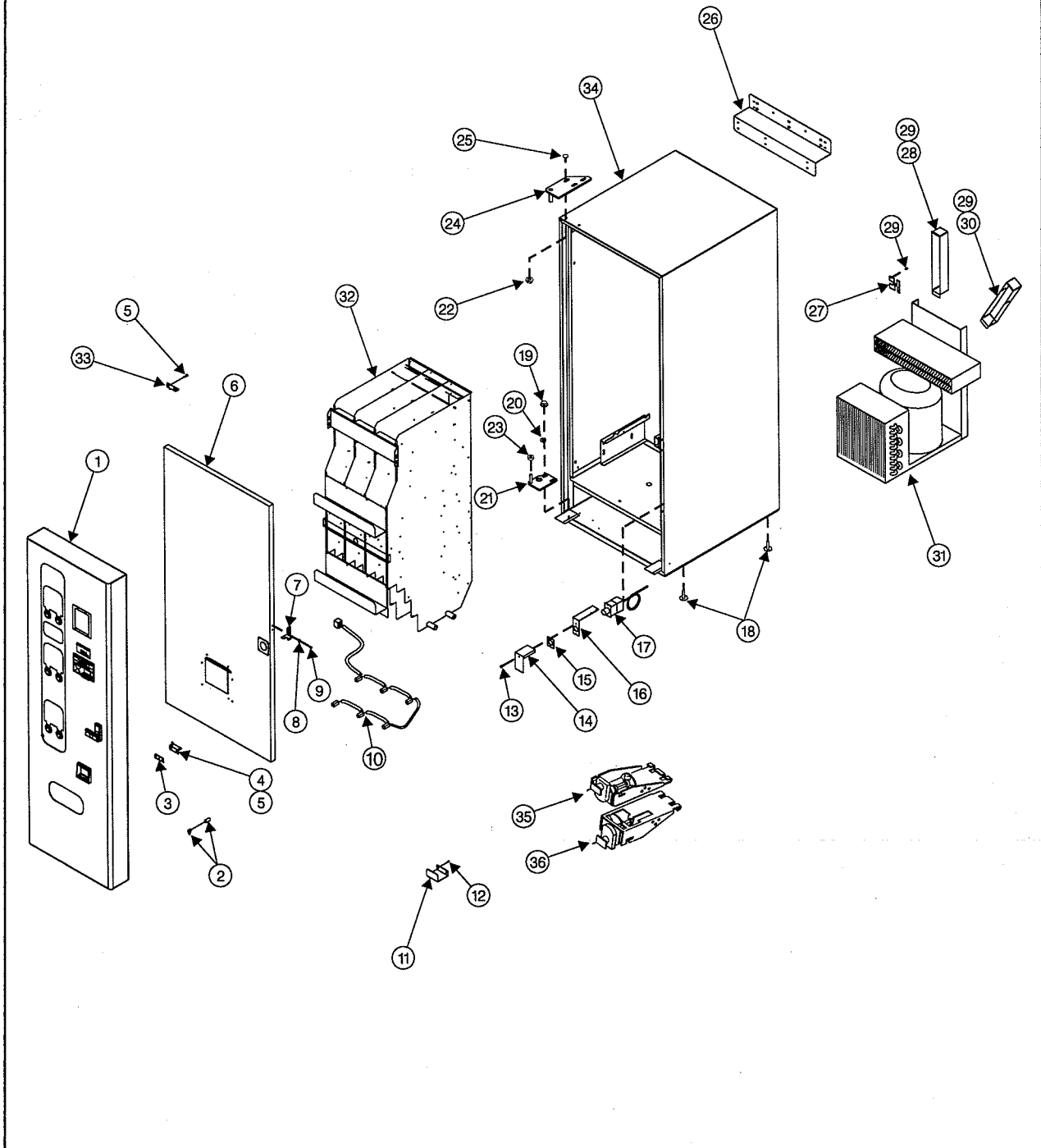

**FINAL ASSEMBLY**

1	1212163	1	DOOR ASSEMBLY - See Page #12
2	4060330	1	LOCK CYLINDER W/2 KEYS
3	4203079	1	HINGE SPACER
4	1211397	1	INNER HINGE WELD - BOTTOM
5	8810030	6	#8-16 X 5/16 PHIL PH TYPE B
6	1212020	1	INNER DOOR ASSY - See Page #10
7	4205002	1	INNER DOOR LATCH
8	4030100	2	BUSHING - SPACER
9	4050180	2	#8-18 X 1/2 PHIL PH TEK
10	4203689	1	CABINET HARNESS
11	4202992	3	MOTOR COVER
12	8800636	6	#8-18 X 1/2 PHIL PH TYPE B
13	4050234	2	#8-32 X 3/8 PHIL TH MS
14	4205856	1	THERMOSTAT COVER
15	4202547	1	LABEL - THERMOSTAT
16	4202330	1	THERMOSTAT MOUNT
17	4202526	1	THERMOSTAT
18	4060310	4	LEG LEVELER
19	8801388	2	#5/16-18 X 3/4 HWH TYPE D
20	7186148-000	2	#5-16 SPLIT LOCK WASHER
21	1212057-XXX	1	BOTTOM HINGE (Specify Color when Ordering)
22	8810015	3	#5/16-18 FLANGE LOCK NUT
23	4050767	3	3/8 FLAT WASHER - NYLON
24	1212055-XXX	1	TOP HINGE (Specify Color when Ordering)
25	4050099	3	#5/16-18 X 3/4 CARRIAGE BOLT
26	4203757	1	WALL MOUNT BRACKET
27	4202552	1	TRI-CORDER PLATE
28	4205787	1	SUCTION LINE COVER
29	4050202	19	#8-18 X 1/2 PHIL HWH TEK
30	4205788	1	CORD COVER - SATELLITE
31	1212326-003	1	REFER SYSTEM - R-134a - See Page #16 & #18
32	1212162	1	CAN RACK - See Page 6
33	1211397-002	1	INNER HINGE WELD - TOP
34	1212238	1	CABINET ASSEMBLY - See Page 4
35	1211443	3	UPPER EJECTOR MECH - See Page #9
36	1211444	3	LOWER EJECTOR MECH - See Page #9
	4203768	1	CONTROL PANEL DECAL - Not Shown
	4205307	1	WARNING LABEL - Not Shown

# CABINET ASSEMBLY

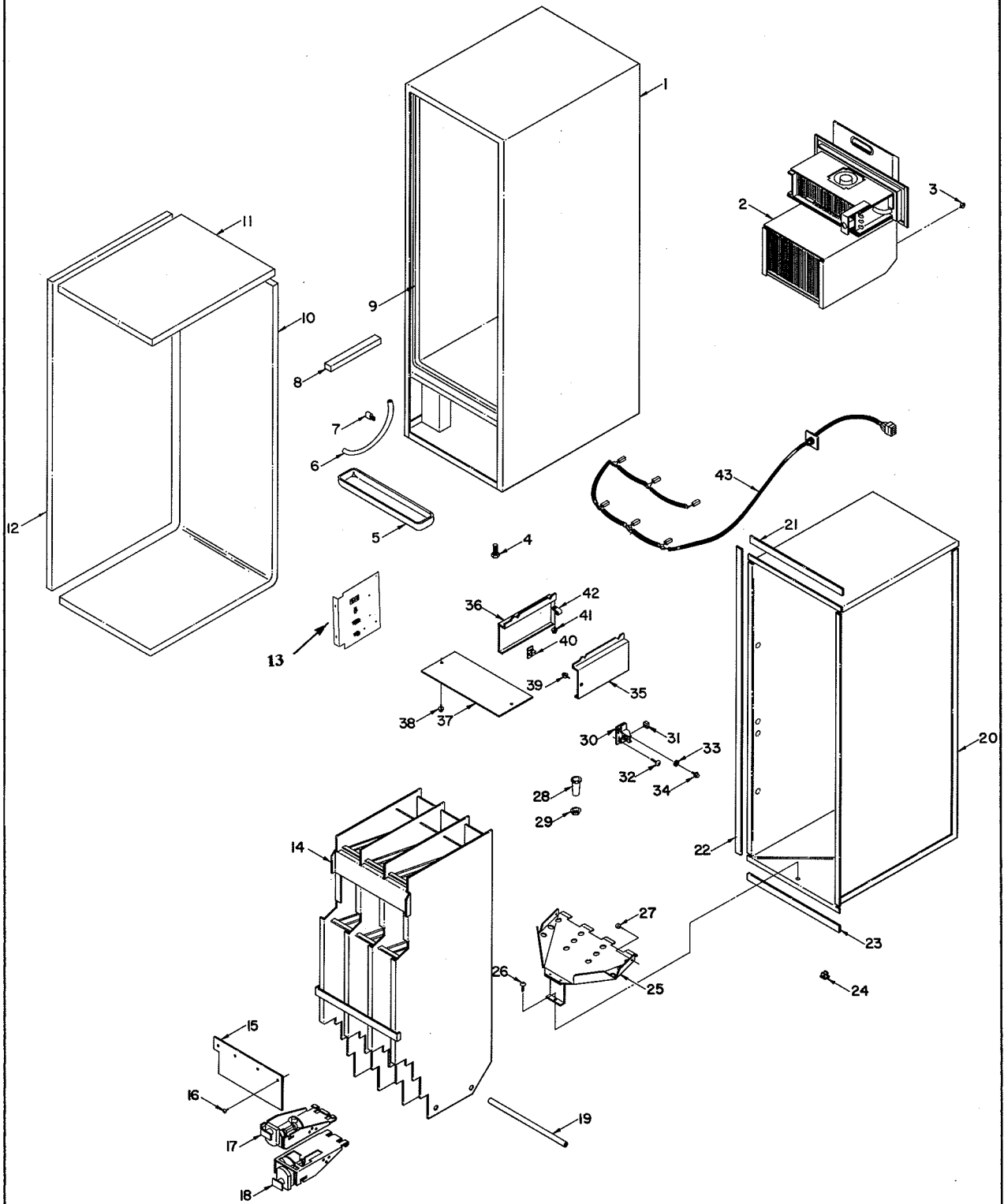

**CABINET ASSEMBLY**

ITEM	PART NUMBER	QTY.	DESCRIPTION
1	1211430-XXX	1	CABINET WELD (Specify Color when ordering)
2	1212326-003	1	REFRIGERATION SYSTEM - (See Page #16)
3	4050202	A/R	#8-18 X 1/2 PHIL HWH TEK
4	4060310	4	LEG LEVELER
5	7200623-000	1	DRAIN PAN
6	4025410-008	1	TUBING - MAYON - 28"
7	7200341-000	1	TUBE CLIP
8	4201398	2	WOOD - LINER SUPPORT
9	7960247-000	13.5 ft.	"A" FRAME GASKET
10	4202286	1	BACK & BOTTOM INSULATION
11	4202287	1	TOP INSULATION
12	4202285	2	SIDE INSULATION
13	1212166	1	TRANSFORMER PLATE ASSEMBLY (See Page 8)
14	1212162	1	COMPLETE CAN RACK ASSEMBLY (See Page 6)
15	4201555	1	MOTOR COVER
16	8800636	8	#8-18 X 1/2 PHIL PH SCREW TYPE B
17	1211443	3	UPPER EJECTOR MECH (See page #9)
18	1211444	3	LOWER EJECTOR MECH (See page # 9)
19	8620197-002	2	TUBE - RACK SUPPORT
20	1211179	1	LINER WELD ASSEMBLY
21	4202278-002	1	1.56 W X 20.75 FOAM TAPE
22	4202278-001	2	1.56 W X 54.31 FOAM TAPE
23	4202279-001	1	1.25 W X 20.75 FOAM TAPE
24	4202189	10	SNAP IN PLASTIC SPRING
25	1211213-001	1	CAN CHUTE ASSEMBLY
26	7200468-001	4	#10-12 X 1 PHIL TH SCREW TYPE A
27	8800636	2	#8-18 X 1/2 PHIL PH SCREW TYPE B
28	7100042-000	1	DRAIN TUBE
29	4202284	1	.500 STUD DIA. PUSH NUT
30	1212111-002	1	LOCK NUT BRACKET WELD
31	4050760	1	1/2-13 SQUARE NUT W/RETAINER
32	7200468-001	6	#10-12 X 1 PHIL TH SCREW TYPE A
33	8801011	1	#8 FLAT WASHER
34	4201239	2	#1/4-20 X 3/4 HWH TAPTITE SCREW
35	4202345-001	1	CAN RACK SUPPORT - RIGHT
36	4202345	1	CAN RACK SUPPORT - LEFT
37	4202347	1	AIR BAFFLE
38	4050202	20	#8-18 X 1/2 PHIL HWH TEK SCREW
39	4201239	8	#1/4-20 X 3/4 HWH TAPTITE SCREW
40	8370959	1	CLAMP LOCKING
41	4050202	1	#8-18 X 1/2 PHIL HWH TEK SCREW
42	7090002-713	1	CLAMP - 3/4
43	4203698	1	MOTOR HARNESS
	7250135-002	2	HOLE PLUG - 1" DIA. (Not Shown)

A/R = As Required

# CAN RACK ASSEMBLY

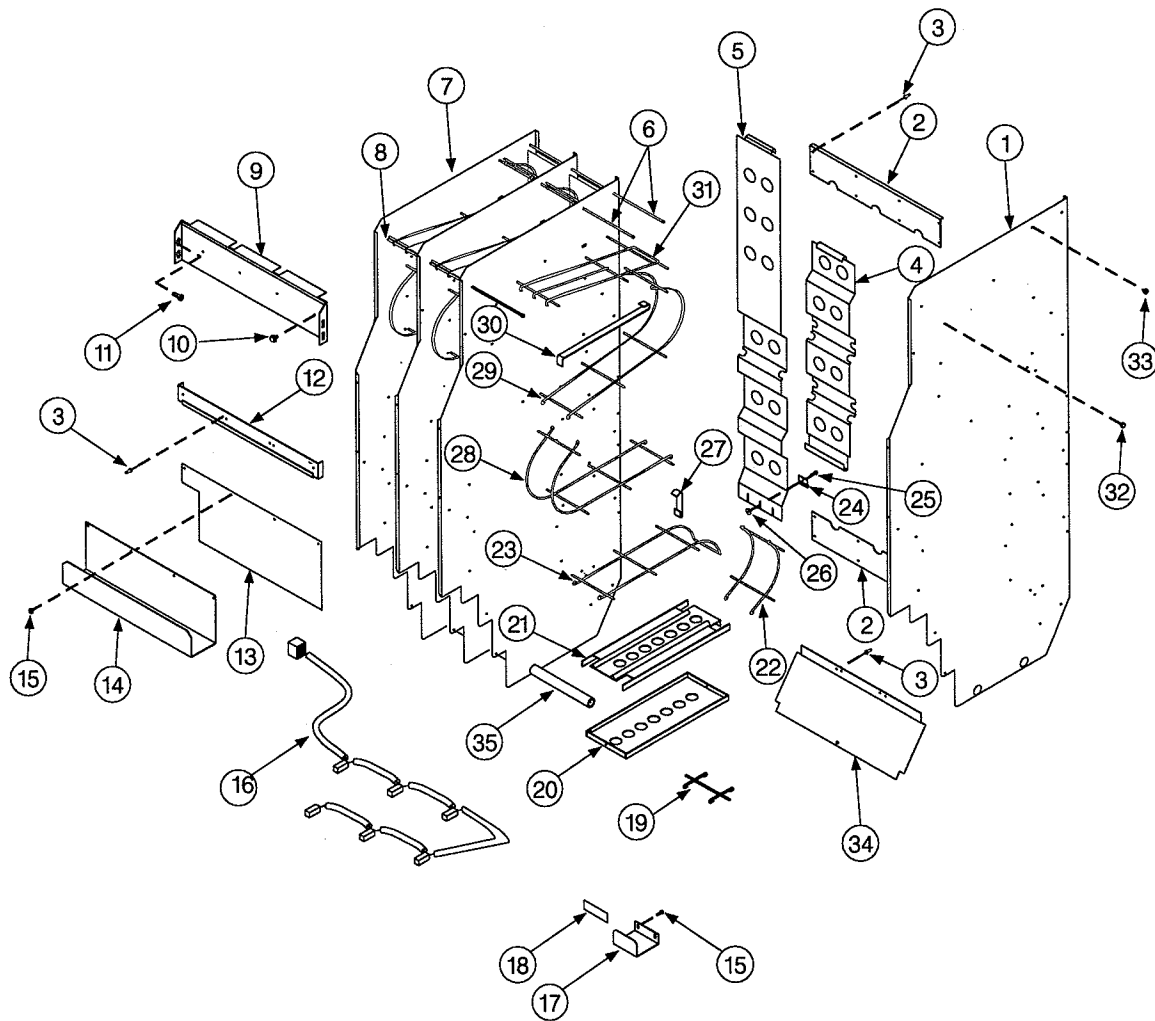

**COMPLETE CAN RACK ASSEMBLY**

ITEM	PART NO.	QTY	DESCRIPTION
	1212162	1	COMPLETE CAN RACK ASSEMBLY
1	4202357	3	PARTITION PANEL - RIGHT
2	4201562-001	2	TOP & BOTTOM TIE STRIP
3	4050665	22	POP RIVET - 1/8 X 1/4
4	4201548	3	CAN DEFLECTOR - SHORT
5	4201549	3	CAN DEFLECTOR - LONG
6	7332474-003	43	.156 DIA. TIE ROD
7	4202357-001	1	PARTITION PANEL - LEFT
8	7332473-002	2	.125 DIA. TIE ROD
9	4201564	1	FRONT TIE STRIP
10	8810014	4	#12-14 X 1/2 PHIL TH TYPE AB
11	4201239	4	#1/4-20 X 3/4 HWH TAPTITE
12	4201630	1	LOWER FRONT TIE STRAP
13	4201555	1	MOTOR COVER - TOP
14	4205003	2	PRE COOL STORAGE SHELF
15	8800636	14	#8-18 X 1/2 PHIL PH TYPE B
16	4203689	1	CABINET HARNESS
17	4202992	3	MOTOR COVER
18	4202255	8 1/2"	GASKET - 1/4 X 3/4 (WITH ADHESIVE)
19	4201535	3	WIRE SHELF - BOTTOM
20	4201558	3	BOTTOM SHELF INSERT
21	4201560	3	BOTTOM SHELF
22	4201534	3	BOTTOM LOOP
23	7331975-000	6	TOP LOOP
24	4201552	3	DEFLECTOR PLATE SUPPORT
25	4050240	3	#8-32 X 3/8 PHIL PH MS
26	8800956	3	#8-32 HEX NUT W/ETW
27	4201551	3	HANGER STRAP
28	7331974-000	12	CENTER LOOP
29	7331974-002	3	CENTER LOOP
30	7331999-000	18	RETAINER STRAP
31	7331977-000	6	UPPER SHELF
32	7332477-000	2	.125 DIA STUD PUSH NUT
33	7332476-000	43	.156 DIA STUD PUSH NUT
34	4202346	1	BACK AIR BAFFLE
35	8620197-002	2	TUBE - RACK SUPPORT
	4201621	1	RACK LOADING LABEL (Not Shown)
	4201660	1	EJECTOR MECH LABEL (Not Shown)
	4206235	1	COOLING LABEL (Not Shown)



## TRANSFORMER/PLATE ASSEMBLY

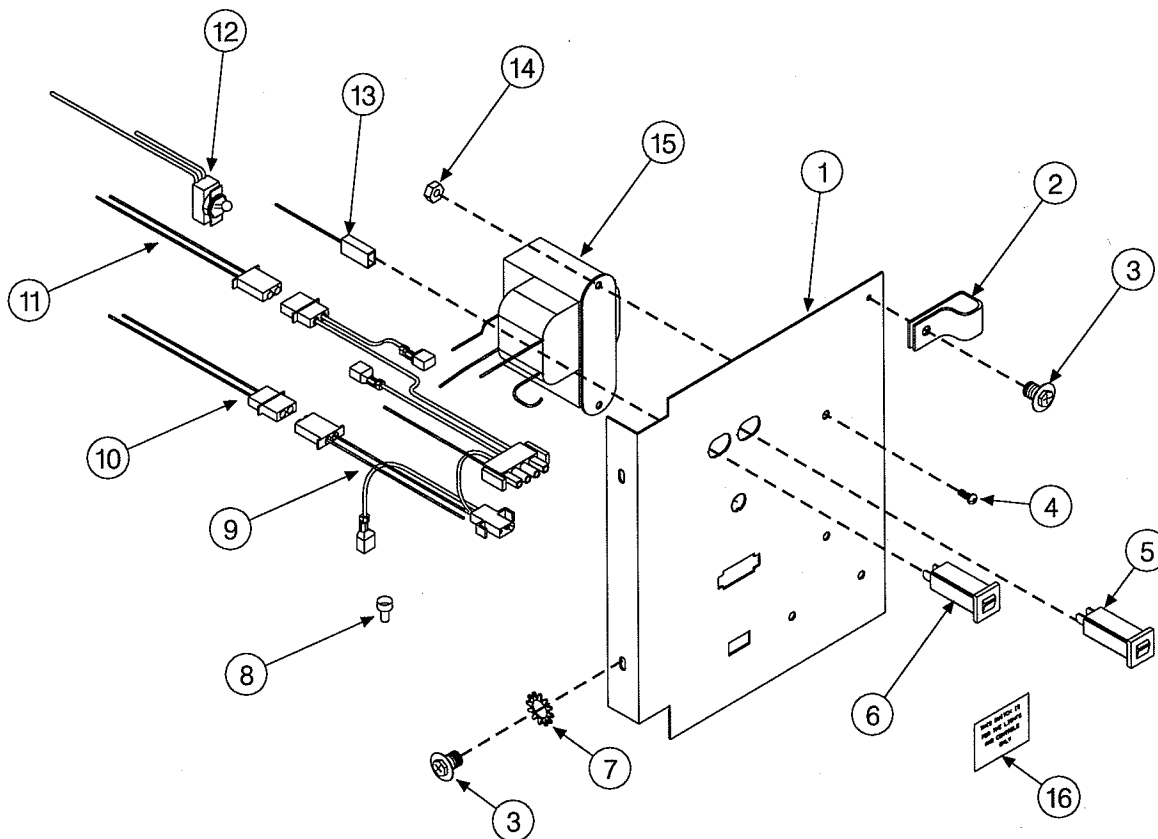

ITEM	PART NUMBER	QTY	DESCRIPTION
	1212166	1	TRANSFORMER PLATE ASSEMBLY
1	4203668	1	TRANSFORMER PLATE
2	7090002-713	2	3/4 CABLE CLAMP
3	4050202	3	#8-18 X 1/2 PHIL HWH TEK
4	4050240	2	#8-32 X 3/8 PHIL PH MS
5	4203467-003	1	3 AMP CIRCUIT BREAKER
6	4203467-005	1	5 AMP CIRCUIT BREAKER
7	4050585	2	#8 EXT SHAKEPROOF WASHER
8	4033505	6	CLOSED END SPLICE CAP
9	4203699	1	POWER BOX HARNESS
10	4033976	1	TRANSFORMER HARNESS - 110 VOLT
11	4033975	1	TRANSFORMER HARNESS - 24 VOLT
12	4033511	1	TOGGLE SWITCH
13	4202941	1	5 AMP BREAKER LINE
14	8800956	2	#8-32 HEX NUT W/ETW
15	1210952	1	TRANSFORMER
16	4203747	1	POWER SWITCH LABEL

## COMPLETE EJECTOR MECH ASSEMBLY UPPER & LOWER

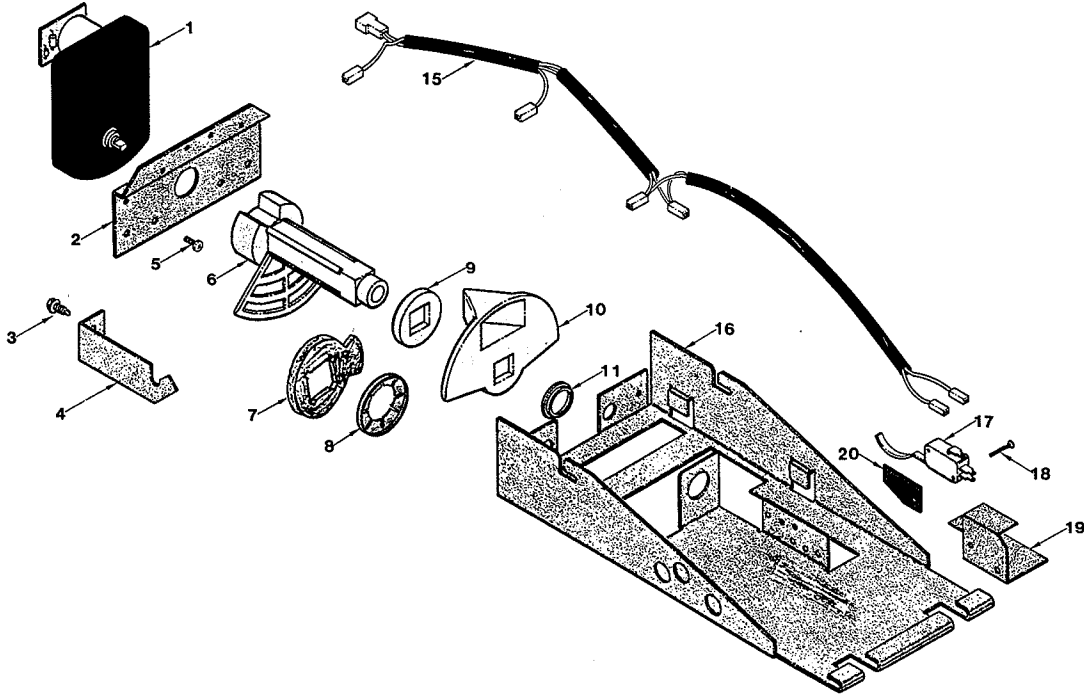

ITEM	PART NUMBER	QTY	DESCRIPTION
	1211443	3	UPPER EJECTOR MECH ASSY
	1211444	3	LOWER EJECTOR MECH ASSY
1	4202826	1	MOTOR - EJECTOR MECH
2	4201328	1	MOTOR MOUNT PLATE
3	4050202	3	#8-18 X 1/2 PHIL HWH TEK
4	4201326	1	RETAINING BRACKET
5	8800636	2	#8-18 X 1/2 PHIL PH TYPE B
6	4201162	1	CAM - LARGE
7	4201542	1	AUXILIARY EJECTOR (LOWER EJECTOR MECH ONLY)
8	4201628	1	CAM SHAFT RETAINER (LOWER EJECTOR MECH ONLY)
9	4201160	1	SPACER
10	4201161	1	CAM - SMALL
11	8620714	1	BUSHING - SNAP-IN
15	4202946	1	EJECTOR MECH HARNESS
16	4201327	1	MECH PLATE
17	8620718	1	SOLD OUT SWITCH
18	8801332	2	#4-40 X 3/4 PHIL PH TAPTITE
19	4201561	1	SWITCH COVER
20	4003735	1	SWITCH INSULATOR
21	4202992	1	MOTOR COVER - BOTTOM (LOWER MECH ONLY NOT SHOWN)

# INNER DOOR ASSEMBLY

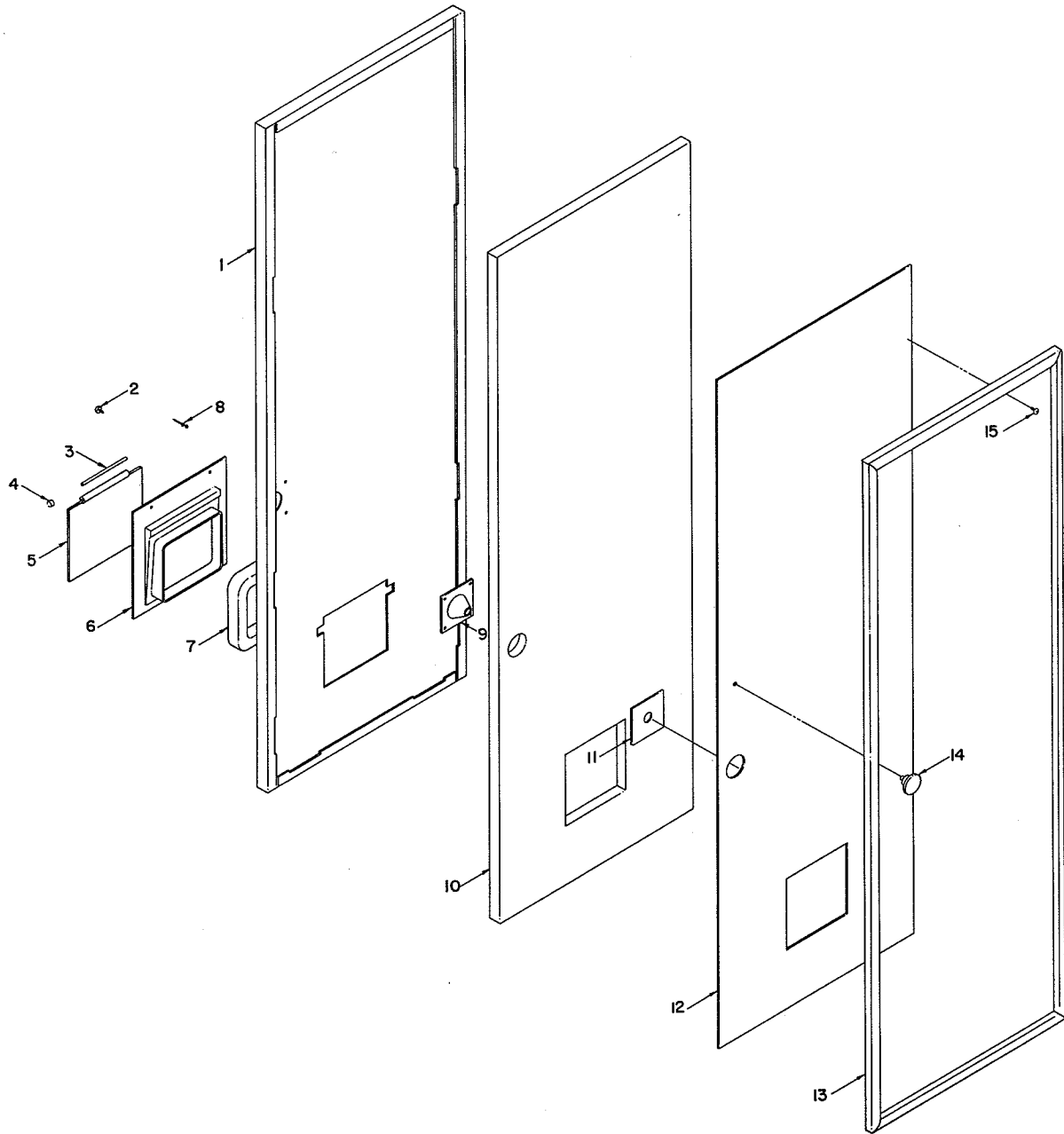

<b>INNER DOOR ASSEMBLY</b>			
<b>ITEM</b>	<b>PART NUMBER</b>	<b>QTY.</b>	<b>DESCRIPTION</b>
	1212020	1	INNER DOOR ASSEMBLY
1	1211423	1	INNER DOOR WELD
2	7334559-000	1	#8-32 X 1/2 PHIL PH MS
3	7200650-001	1	HINGE PIN
4	7091078-000	2	TUBULAR SPEED NUT
5	7334428-001	1	VEND PORT DOOR
6	4202758	1	DELIVERY CHUTE
7	4202255	2	GASKET - 1/4 X 3/4 W/ADHV
8	4050667	4	1/8 X 1/4 ALUM POP RIVET
9	4202760	1	LOCK FUNNEL - INNER DOOR
10	4203080	1	INNER DOOR INSULATION
11	4205517	1	INSULATION SHIELD
12	4202795	1	INNER DOOR BACK
13	4201203-001	1	DOOR GASKET
14	4203028	1	KNOB
15	4050202	34	#8-18 X 1/2 PHIL HWH TEK
16	4203748	1	OPERATING INSTRUCTION LABEL (Not Shown)

# DOOR ASSEMBLY

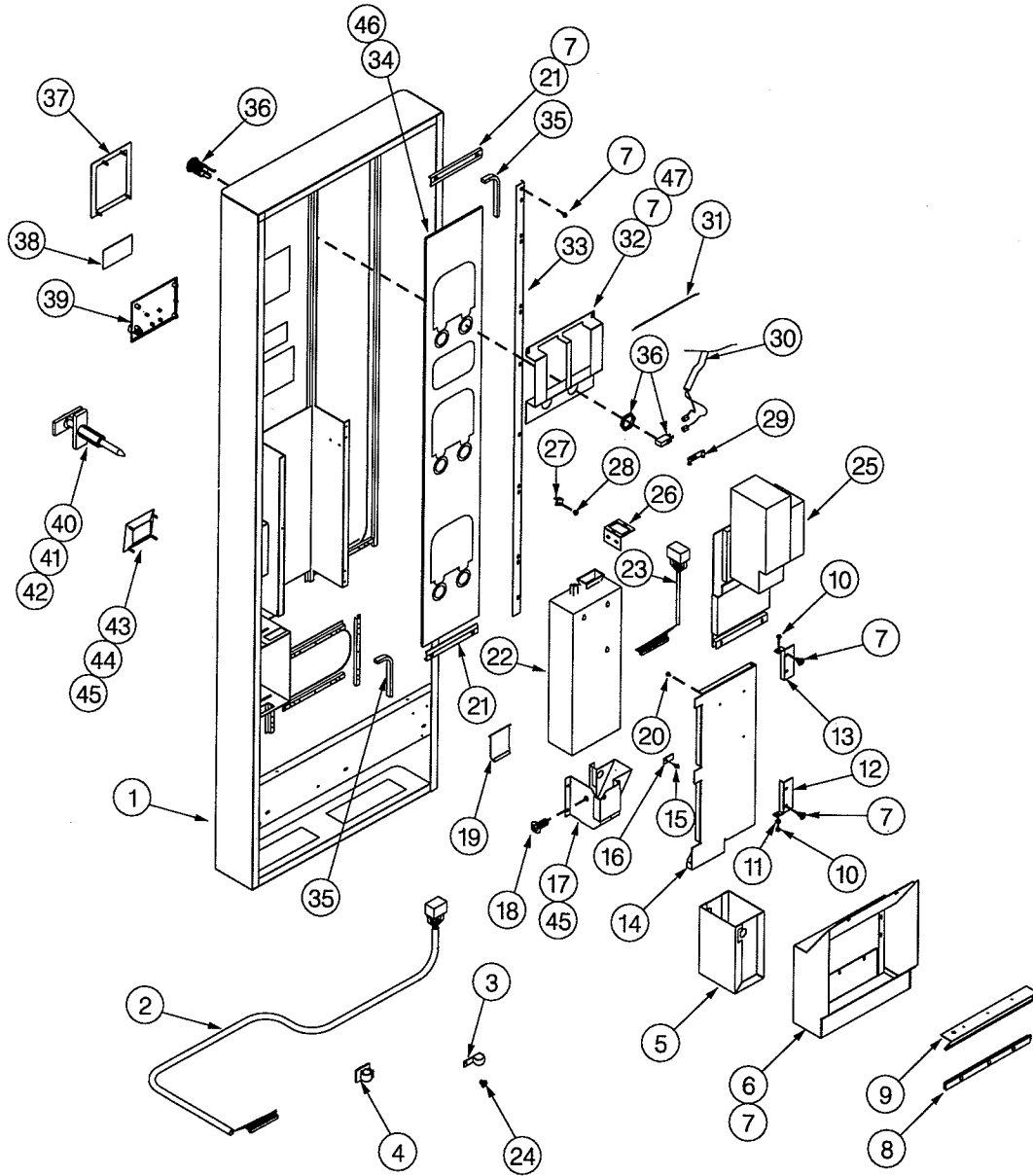

<b>DOOR ASSEMBLY</b>			
1	1211110-XXX	1	DOOR WELD (Specify Color)
2	4203701-001	1	DOOR HARNESS
3	4060116	7	PLASTIC WIRE CLAMP - 3/8
4	8370959	2	LOCKING CLAMP - 1/2
5	1212112	1	COIN BOX WELD
6	1212114	1	DELIVERY WELD
7	4050420	43	#8-18 X 1/4 PHIL HWH TYPE B
8	4203797	1	CAN BUMPER
9	4203798	1	ANTI THEFT
10	8800636	2	#8-18 X 1/2 PHIL PH TYPE B
11	4203029	2	WASHER - INNER DOOR
12	4203670-000	1	MECH DOOR HINGE - BOTTOM
13	4203670-001	1	MECH DOOR HINGE - TOP
14	1212113-XXX	1	MECH DOOR WELD (Specify Color)
15	8800767	1	#8-32 X 12 PHIL PH TYPE T
16	4203669	1	DOOR LATCH
17	1212124	1	COIN CUP WELD
18	4201239	1	#1/4-20 X 3/4 HWH TAPTITE
19	4202068	1	COIN CUP DOOR
20	8800498	3	#8-18 X 3/8 PHIL PH TYPE B
21	4203092	2	WINDOW RETAINER
22	4200419	1	COIN MECH - COINCO 9302-L
23	4203715	1	COIN MECH HARNESS
24	7200470-002	1	#8-32 X 5/16 PHIL RH SEMS
25		1	VALIDATOR - CONTROLLER COMPONENTS (See Page #14)
26	4202872	1	PLUG BRACKET
27	4009751	2	COIN INSERT BRACKET
28	4050212	4	#8-32 X 1/4 PHIL PH TYPE T
29	4203341	6	PRICE SCROLL
30	4203700-001	1	SELECTION HARNESS
31	8379539-000	3	SPRING - EXTENSION
32	4203739	3	CAN MOUNT SCROLL
33	4205004	2	RETAINER - SIDE
34	4203569	1	DISPLAY WINDOW
35	4025735-900	10.5 Ft	TRIM-LOK - BLACK
36	4203703-000	6	SELECTION SWITCH - BLACK
37	1210256-000	1	VALIDATOR PLATE WELD
38	4202841-003	1	READOUT WINDOW
39	1212165	1	COIN INSERT CASTING ASSY (See Page #15)
40	4060417-XXX	1	T-HANDLE(Specify Color)
41	4050338	2	#10-32 x 1/2 PHIL FH MS
42	8800952	2	#10-32 HEX NUT W/ETW
43	7334281-002	1	CHANGE BEZEL
44	7334984-000	1	CHANGE LABEL
45	7334982-000	4	.156 DIA STUD SELF THREAD NUT
	4203750	1	TILT LABEL (Not Shown)
	4203792	1	BRACKET LABEL (Not Shown)

## VALIDATOR - CONTROLLER COMPONENTS

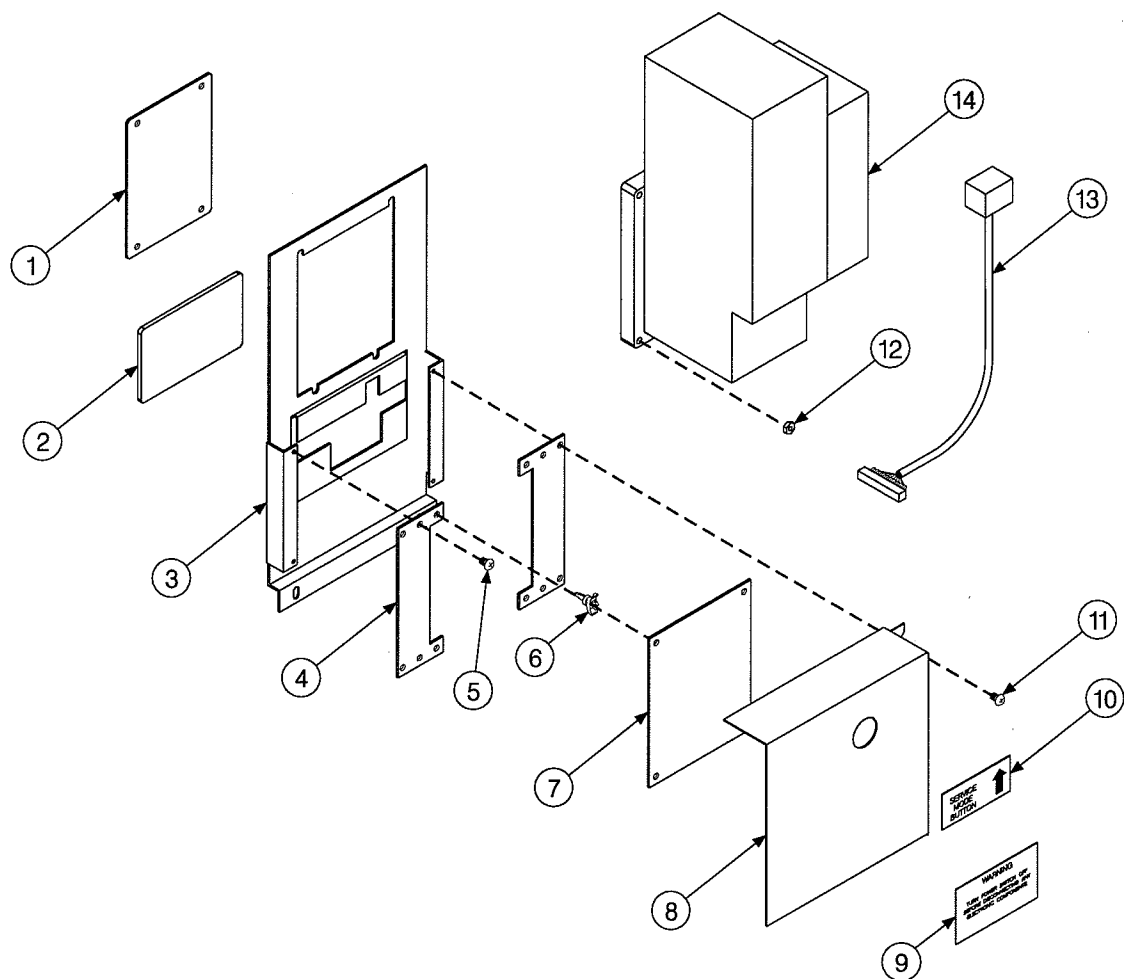

ITEM	PART NUMBER	QTY	DESCRIPTION
1	4201907	1	VALIDATOR PLATE (Used When Validator is Removed)
2	4202841-003	1	READOUT WINDOW
3	4205001	1	CONTROL BOARD MOUNT
4	4205005	2	BOARD RETAINER
5	4050120	4	#6-32 X 5/16 PHIL PH TYPE T
6	4025738	4	STAND-OFF
7	4203712	1	CD 12 CONTROLLER
8	4205006	1	CONTROL BOARD COVER
9	8620711	1	POWER SWITCH WARNING LABEL
10	4202995	1	SERVICE MODE LABEL
11	4050120	2	#6-32 X 5/16 PHIL PH TYPE T
12	8800956	4	#8-32 HEX NUT W/ETW
13	4202938	1	VALIDATOR HARNESS - MAKA - 110 VOLT
	4202938-24	1	VALIDATOR HARNESS - MAKA - 24 VOLT
	4203619-024	1	VALIDATOR HARNESS - COINCO/MARS -24 VOLT
14	4202765-002	1	VALIDATOR - MAKA - 110 VOLT
	4202765-242	1	VALIDATOR - MAKA - 24 VOLT
	4205536-017	1	VALIDATOR - COINCO - 24 VOLT

## COIN INSERT CASTING ASSEMBLY

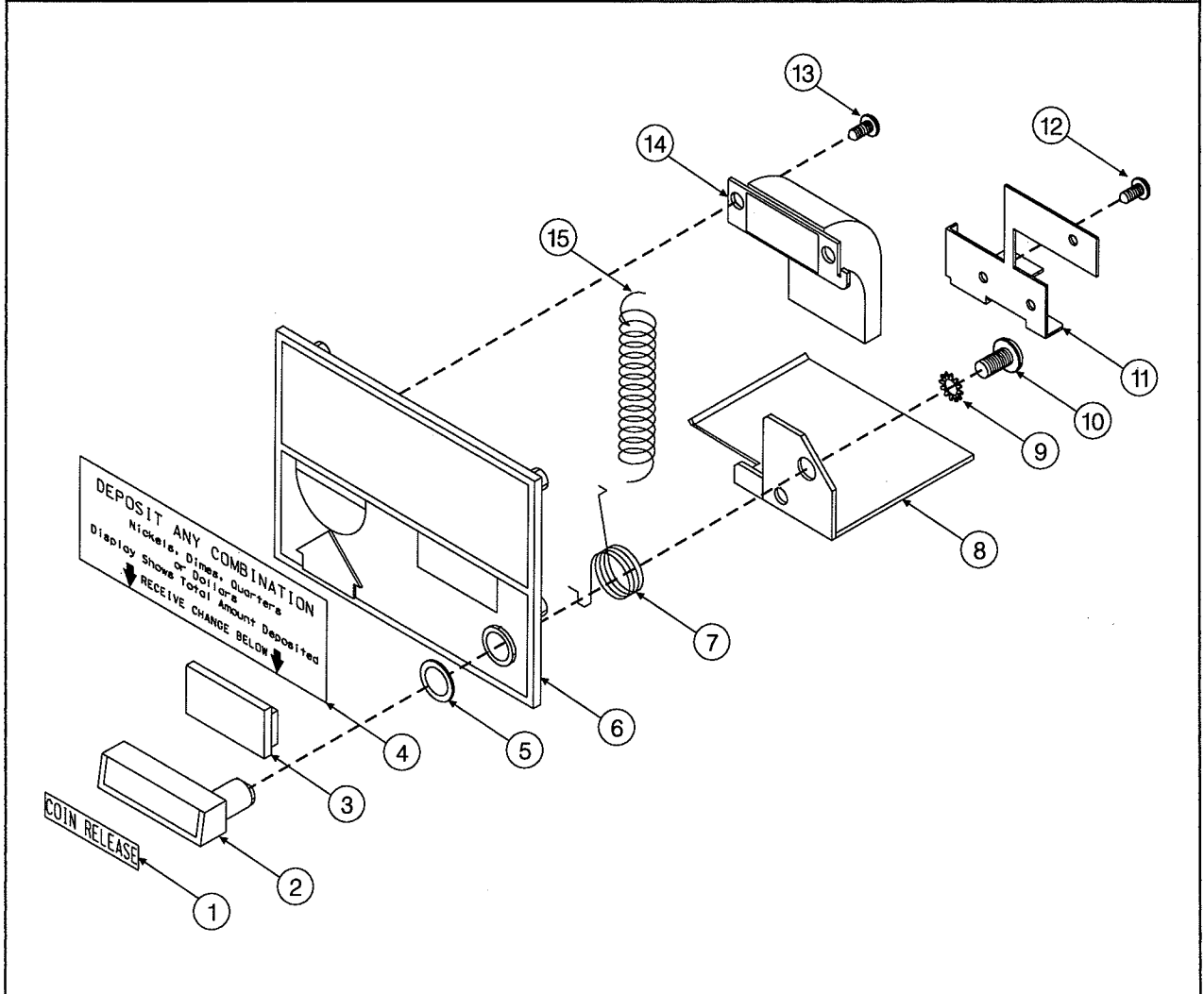

ITEM	PART NUMBER	QTY	DESCRIPTION
	1212165	1	COIN INSERT CASTING ASSEMBLY
1	7334370-000	1	COIN RELEASE DECAL
2	7334283-XXX	1	COIN RELEASE HANDLE - Specify Color when ordering
3	4025725	1	FILLER PLUG
4	4020837-001	1	COIN & DOLLAR INSERT LABEL
5	7100816-000	1	3/8 FLAT NYLON WASHER
6	4060372-XXX	1	COIN INSERT CASTING - (Specify Color when ordering)
7	7091076-100	1	TORSION SPRING - 11/32
8	7334983-000	1	COIN RELEASE LEVER
9	7200717-008	1	#12 INT/EXT LOCK WASHER
10	7200469-020	1	#1/4-28 X 1/2 PHIL TH MS
11	4202056	1	COIN CHUTE RETAINER
12	4201942	3	#6-20 X 3/16 PHIL PH TYPE B
13	7310057-000	2	#6-20 X 1/4 PHIL TH TYPE B
14	4201159-002	1	COIN CHUTE - RETURN
15	4021024	1	SPRING



# REFRIGERATION SYSTEM - R134a

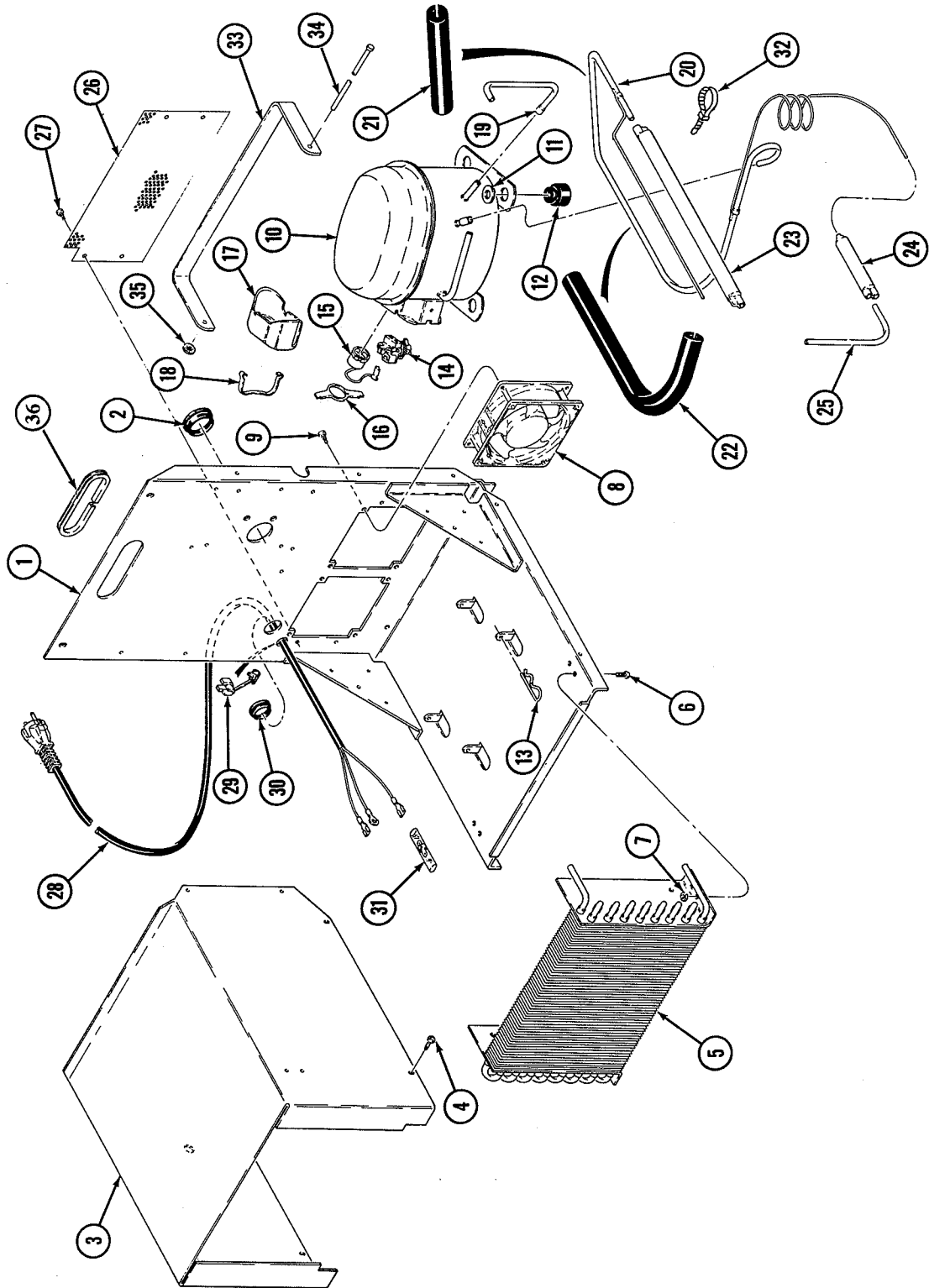

**REFRIGERATION SYSTEM - R-134a**

<b>ITEM</b>	<b>PART NUMBER</b>	<b>QTY.</b>	<b>DESCRIPTION</b>
	1212326-003	1	REFRIGERATION SYSTEM - 110 VOLT - R134a
1	1212209-001	1	REFER BASE WELD
2	8359801-2	1	SNAP BUSHING - SPLIT
3	4202328	1	COMPRESSOR COVER
4	4050202	8	#8-18 X 1/2 PHIL HD TEK SCREW
5	4060477	1	CONDENSER COIL
6	4050240	4	#8-32 X 3/8 PHIL PH MS
7	4050513	4	#8-32 TWIN WHIZ LOCK NUT
8	4034344-000	2	EVAPORATOR FAN - 115 VOLT
9	8800829	8	#10-24 X 3/8 PHIL TH W/ETW
10	4203789	1	COMPRESSOR - 1/4 HP - 115 VOLT
11	4050608	4	1/2 FLAT WASHER
12	8323090-1	4	GROMMET - COMPRESSOR
13	4050773-001	4	HITCH PIN
14	8333894-8	1	RELAY - STARTING - 115 VOLT
15	8045052-12	1	OVERLOAD PROTECTOR - 115 VOLT
16	8344305	1	SPRING - OVERLOAD
17	8344308	1	COVER - TERMINAL
18	8344306	1	BALE STRAP
19	4060716	1	DISCHARGE LINE
20	1212219	1	SUCTION LINE WELD
21	8365271-1	1	INSULATION - 8 INCHES
22	8365271-3	1	INSULATION - 24 INCHES
23	4060480-001	1	ACCUMULATOR - 13 INCHES
24	4205468	1	DRIER
25	4202633	1	SERVICE LINE
26	4205106	1	FAN GUARD
27	8800766	4	#8-32 X 1/2 PHILLIPS SCREW PH TYPE T
28	4033631-000	1	POWER CORD - 115 VOLT
29	4033683	1	CORD - STRAIN RELIEF BUSHING
30	8359801-2	1	SNAP BUSHING - SPLIT
31	4033527	2	CONNECTOR - LINE SPLICE
32	4033712	3	CABLE TIE
33	4205306	1	STANDOFF BRACKET
34	7332474-008	1	TIE ROD
35	73324736-000	1	.156 DIA. STUD PUSH NUT
36	4033652-002	1	EXTRUDED GROMMET - 9 1/4 INCHES
	4203702	1	POWER HARNESS (Not Shown)

# REFRIGERATION SYSTEM - R134a

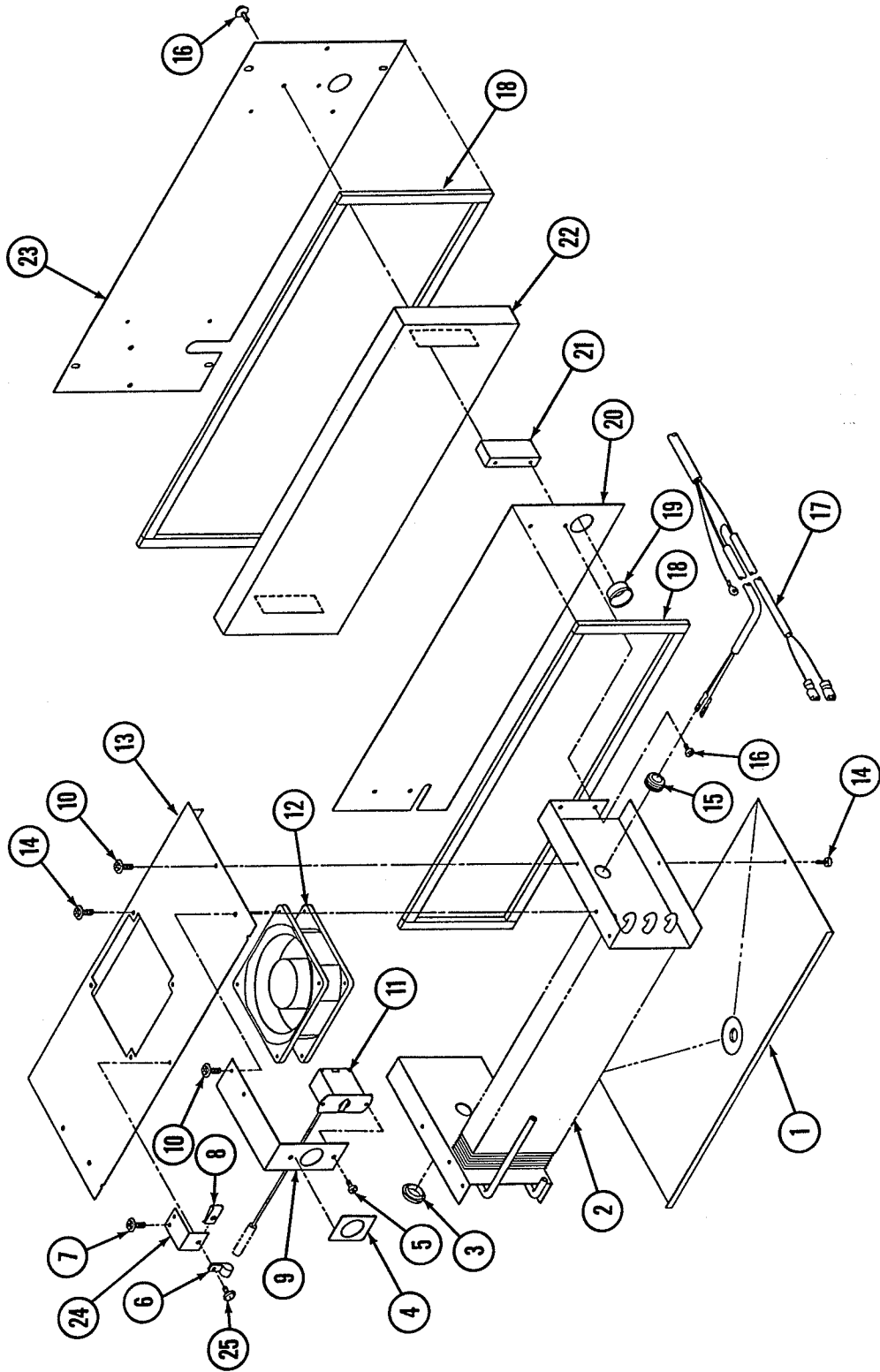

**REFRIGERATION SYSTEM - R-134a**

<b>ITEM</b>	<b>PART NUMBER</b>	<b>QTY.</b>	<b>DESCRIPTION</b>
	1212643	1	EVAPORATOR ASSEMBLY - 115 VOLT
1	4206100	1	CONDENSATE PAN
2	4206047	1	EVAPORATOR COIL
3	7250135-003	1	HOLE PLUG, BPF-3/4
4	4202547	1	LABEL - THERMOSTAT
5	4050240	2	#8-32 X 3/8 PHIL PH MACHINE SCREW
6	4060116	1	PLASTIC WIRE CLAMP
7	4050202	2	#8-18 X 1/2 PHIL HWH TEK
8	8352837	1	#10-32 "U" TYPE SPRING NUT
9	4202330	1	THERMOSTAT MOUNT
10	8800852	4	#8-32 X 3/8 PH TYPE "T"
11	4202526	1	THERMOSTAT
12	4034344-000	1	EVAPORATOR FAN
13	4206101	1	EVAPORATOR COVER
14	8800829	6	#10-24 X 3/8 PHIL TH W/ETW
15	4203181-002	1	SNAP BUSHING
16	8801322	8	#8-18 X 1/2 PHIL PH HILO
17	4202327	1	HARNESS - REFRIGERATION
18	4060006-500	8.5 FT	1/4" X 1/2" FOAM TAPE
19	8359801-2	1	SNAP BUSHING - SPLIT
20	4202312	1	EVAPORATOR MOUNT
21	4202276	2	EVAPORATOR SPACER
22	4202340	1	EVAPORATOR INSULATION
23	4202315	1	EVAPORATOR BACKUP
24	4202316	1	THERMOSTAT BULB BRACKET
25	8800833	1	#10-32 X 1/2 PHIL TH W/ETW
	4203702	1	POWER HARNESS (Not Shown)